

**CURRENT DATE OF REVISION  
MT 400 SECTION  
MISCELLANEOUS MATERIALS AND TEST METHODS**

<b>Test Method No.</b>	<b>Title</b>	<b>Pages</b>	<b>Date of Publication or Revision</b>
MT 401	Eliminated ( <i>Use AASHTO M 196 Corrugated Aluminum Pipe for Sewers and Drains and AASHTO M 197 Aluminum Alloy Sheet for Corrugated Aluminum Pipe</i> )		
MT 402	Eliminated ( <i>Use AASHTO M 36 Corrugated Steel Pipe, Metallic-Coated, for Sewers and Drains</i> )		
<a href="#">MT 403</a>	<a href="#">Sampling and Inspection of Seeding and Landscaping Materials</a> .....	2 pp	Apr 2021
<a href="#">MT 404</a>	<a href="#">Inspecting Wood Products</a> .....	2 pp	Sep 2022
MT 405	Eliminated ( <i>Use AASHTO R 18 Establishing and Implementing a Quality Management System for Construction Materials Testing Laboratories</i> )		
<a href="#">MT 406</a>	<a href="#">Sampling and Inspection of Signing Material and Signs</a> .....	5 pp	Jun 2004
<a href="#">MT 407</a>	<a href="#">Method of Test for High Strength Bolts</a> .....	5 pp	Jun 2020
<a href="#">MT 408</a>	<a href="#">Method of Sampling and Field Testing Brine Deicing Material</a> .....	3 pp	Feb 2010
<a href="#">MT 409</a>	<a href="#">Welded Stud Shear Connectors</a> .....		Under Development
MT 410	Eliminated		
MT 411	Vacant		
<a href="#">MT 412</a>	<a href="#">Topsoil Sampling, Sample Preparation and Testing</a> .....	2 pp	Sep 2018
MT 413	Eliminated ( <i>Use AASHTO M 181 Chain-Link Fence, AASHTO M 279 Metallic-Coated, Steel Woven Wire Fence Fabric, AASHTO M 280 Metallic-Coated (Carbon) Steel Barbed Wire, and AASHTO M 281 Steel Fence Posts and Assemblies, Hot-Wrought</i> )		
<a href="#">MT 414</a>	<a href="#">Method of Acceptance for Reinforcing Steel</a> .....	4 pp	Jun 2023
<a href="#">MT 415</a>	<a href="#">Structural Steel</a> .....		Under Development
MT 416	Vacant		
MT 417	Vacant		
<a href="#">MT 418</a>	<a href="#">Method of Acceptance for Miscellaneous Welded Items</a> .....	1 pp	Sep 2021
MT 419	Vacant		
<a href="#">MT 420</a>	<a href="#">Procedure to Check for Leaks Under Hydrostatic Pressure</a> .....	3 pp	Jun 2004
MT 421	Eliminated ( <i>Use AASHTO M 288 Geosynthetic Specification for Highway Applications</i> )		
<a href="#">MT 422</a>	<a href="#">Method of Test for Surface Smoothness and Profile</a> .....	4 pp	Apr 2012



**METHODS OF SAMPLING AND TESTING**  
**MT 403-21**  
**SAMPLING AND INSPECTION OF SEEDING AND LANDSCAPING MATERIALS**

**1 Scope**

- 1.1 This procedure describes the inspection and sampling procedures for revegetation materials including seed, fertilizer, mulch, sod, and nursery stock.

**2 Seed Supplier Inspection**

- 2.1. Reclamation seed is required to come from seed suppliers on the Qualified Products List (QPL). Seed suppliers on the QPL will be randomly inspected.
- 2.1.1 Seed blend records and test results for MDT projects will be reviewed by the inspector to ensure the blends meets MDT seed blend requirements.
- 2.1.2 Seed blend samples, collected by the seed supplier for each seed blend used on MDT projects, will be taken back to the MDT Materials Laboratory (District or Headquarters) by the inspector. Seed blend samples will be maintained for one year for seed blend verification, if necessary.

**3 Seed Sampling Procedure (Field)**

- 3.1 Reclamation seed is accepted with a datasheet (seed bag tag) from suppliers listed on the QPL only. Landscaping seed is accepted with a datasheet (not required to come from a supplier on the QPL). However, MDT reserves the right to sample and verify any material.
- 3.2 Follow these steps to collect a representative seed sample.
- 3.2.1 When sampling seeds in bags, use a trier long enough to reach all areas in the bag. The trier must be designed so that it will remove an equal volume of seed from each part of the bag through which the trier travels. Unless the trier has partitions in the seed chamber, it must be inserted into the bags horizontally. A trier or probe is available from the Materials Bureau by request and must be returned immediately upon completion of sampling.
- 3.2.2 Sample non-free-flowing seeds that are difficult to sample with a trier by thrusting the hand into the seed and removing representative portions. When a sample is taken with the hand, insert the hand flat and with the fingers together. Keep the fingers together as the hand is closed and withdrawn. Because of possible segregation, hand samples should be taken from various locations in the bags.
- 3.2.3 Submit an 8 oz sample in a new, clean container or plastic zip closure storage bag.
- 3.2.4 Submit the sample to the Material Bureau Laboratory and include the following information: all pertinent project information, supplier's name and address, kind of seed, all of the information given on the purity and germination tag and the amount of seed the sample represents.

**4 Fertilizer**

- 4.1 Fertilizer is accepted with a datasheet. However, MDT reserves the right to sample any material. If a sample is requested, sampling will be performed by field personnel at the project site. In the case of blended fertilizer, a sample of the blended material will be collected for analysis. Obtain sufficient material to fill a one quart (one liter) container from the top, center, and bottom of each fertilizer container to be sampled. Only one sample will be required from each lot.
- 4.2 Each sample submitted to the Materials Bureau will be labeled with the Project ID and accompanied by the certified chemical analysis tag, the supplier's name, the kind of fertilizer, the lot number, and the total pounds the sample represents.

## 5 Mulch

5.1 Mulch is accepted with a datasheet and must be supplied from sources listed on the QPL only. If the mulch contains straw, a certificate of compliance indicating the straw is weed seed free must also be submitted. However, MDT reserves the right to sample and verify any material. If a sample is requested, follow the applicable sampling procedure below.

### 5.2 Vegetative Mulch

5.2.1 Vegetative mulch is dried cereal grain or oilseed crop straw, cornfield residue, or grass hay with the majority of stems and leaves at least 4 inches (100 mm) in length. Vegetative mulch will be inspected in the field for conformance with the project specifications and Standard Specifications (Section 713.10.1). If a sample is requested, submit one pound to the Materials Bureau in a zip closure storage bag. Label the sample with the Project ID, date sampled, source, type, condition, purity, and moisture content of the mulch.

### 5.3 Hydraulic Mulch

5.3.1 Hydraulic mulch includes wood fiber hydraulic mulch, straw fiber hydraulic mulch, and multi-fiber hydraulic mulch. Hydraulic mulch will be inspected in the field for conformance with the project specifications and Standard Specifications (Section 713.10.2). If a sample is requested, submit one pound to the Materials Bureau in a zip closure storage bag. Label the sample with the Project ID, date sampled, source, type, condition, purity, and moisture content of the mulch.

## 6 Sod

6.1 Sod is accepted with a datasheet. However, MDT reserves the right to sample and verify any material. The material will be inspected on-site for signs of stress or lack of water. If a sample is requested, submit one square foot in a sample bag to the Materials Bureau along with the Project ID, date sampled, source, grass species, thickness of sod, and the total quantity of material represented by the sample.

## 7 Nursery Stock (Plants, Trees, and Shrubs)

7.1 Nursery Stock is accepted with a datasheet. The inspection of nursery stock will be performed by the Project Manager for conformance with the specifications contained in the project proposal. **DO NOT SUBMIT SAMPLES** of Nursery Stock. If there is a question about nursery stock consult the District Environmental Services Supervisor.

**METHODS OF SAMPLING AND TESTING**  
**MT 404-22**  
**METHOD FOR INSPECTING WOOD PRODUCTS**  
*(Montana Method)*

**1 Scope**

- 1.1 This method includes the inspection of all wood products in accordance with Standard Specification §706.04.3.
- 1.2 The primary responsibility for the inspection of wood products is assigned to the Inspector at the Materials Bureau.

**2 Reference Documents*****American Wood Protection Association (AWPA) Standards***

- A9 Standard Method for Analysis of Treated Wood and Treating Solutions by X-Ray Spectroscopy
- M2 Standard for the Inspection of Preservative Treated Products for Industrial Use
- M22 Standard for Third-Party Agency Evaluation of Inspection Data

***MDT***

Standard Specifications for Road and Bridge Construction  
Detailed Drawings

**3 Inspection Procedures****3.1 Pretreatment Inspection**

- 3.1.1 Any wood products to be treated may be inspected in the white to determine its suitability for treatment.
- 3.1.2 In accordance with Standard Specification §706.01.03, wood products with worm holes and any staining due to fungus will be inspected in the white. Moisture content of intermountain Douglas fir will also be inspected in the white.
- 3.1.3 Treatment plants will provide the Materials Bureau at least 72 hours notice for inspection in the white.

**3.2 After Treatment Inspection**

- 3.2.1 The MDT Inspector will inspect the wood products after treatment in accordance with AWPA M2 Section 4.

**3.2.1.1 Sample Set**

A sample set will consist of 20 cores from each selected charge.

**3.2.1.2 Sample Rate**

MDT will collect sample sets from at least 50% of the charges designated for MDT projects.

**3.2.1.3 Testing**

Each sample set will be tested for preservative penetration and retention. Penetration and retention must meet the requirements in AWPA Standards U1 and T1, Commodity Specification A, B or D, Use Category 4A for the appropriate application of the material.

Penetration tests will follow the procedures in AWPA M2 Section 4. If more than 20% of the cores fail to meet penetration requirements, sampling will cease and all material in the charge will be

considered a failure.

Retention tests will follow the procedures in AWWPA A9.

- 3.2.2 After inspection, all acceptable large timbers (class 4 utility poles, guardrail posts, pilings, sign posts, etc.) are individually stamped with the Circle (M) stamping hammer and each bundle is sealed with an inspection tag which denotes acceptance prior to shipment.
- 3.2.3 The acceptance of small items (fence posts, etc.) prior to shipment is indicated by inspection seals attached to each bundle.

#### **4 Job Site Final Acceptance**

- 4.1 MDT Field Personnel will conduct a final acceptance inspection to ensure the wood products were pre-inspected and are still in good quality.

**METHODS OF SAMPLING AND TESTING**  
**MT 406-04**  
**METHOD OF SAMPLING AND INSPECTION OF SIGNING MATERIAL AND SIGNS**  
**(Montana Method)**

**1 Scope**

- 1.1 Following the determination of a successful bidder, and upon the letting of a project to contract, a letter is sent to the prime contractor by the Materials Bureau requesting the source of bid items in the contract. These items include signing material and signs. Upon receipt of the information, the Certification Inspection Supervisor in the Materials Bureau will arrange for inspection. The following procedures and requirements shall be observed whenever signs are included in a project.

**2 Referenced Documents**

- 2.1 Montana Department of Transportation Detailed Drawings

**3 Reporting**

- 3.1 A copy of all correspondence, test results, certificates and other pertinent documents shall be submitted to the Materials Bureau, attention Certification Inspection Supervisor.

**4 Signing Material**

- 4.1 Inspection of signing material will be performed by either another state, by a commercial inspection and testing agency, or if the material was not pre-inspected by field personnel.

**5 Sign Fabrication Inspection**

- 5.1 Sign fabrication inspection involves visual observation of sign materials, fabrication procedures, and the manufactured product to ensure that it will serve the intended purpose for its expected performance life.
- 5.2 Material specifications are outlined in the Standard Specifications for Road and Bridge Construction and in the contract special provisions. Materials used in the fabrication of highways signs are inspected by an inspection agency for each construction contract.
- 5.3 In-Plant sign inspection and approval does not constitute mandatory acceptance by the Project Manager of the delivered product. It is possible that signs may be damaged in transit because of inadequate packaging or poor handling and will be rejected at the project site. Approval of a sign at the point of fabrication means that the inspector has assured himself that all materials used meet the plan specifications and that finished signs are satisfactory in appearance and workmanship.

**6 Materials**

- 6.1 Inspection & Sampling: Following is a listing of the materials used in the fabrication of signs and the required sampling procedures before the subject material may be approved for use.
- 6.2 6061 T6 or 5052 H38 Aluminum Sheeting can be accepted on certification of conformance and certified mill test reports. No sample is required unless deemed necessary by the Inspector. If samples are required, they shall be sampled as follows: Two samples of size 3/4 inch x 9 inch of each gauge will be taken from each consignment of aluminum received for signing. Samples will be oriented with the longer dimension parallel to the direction of rolling. The Materials Bureau will machine these samples to comply with ASTM E8-80A. A Certificate of Compliance including Certified Mill Test Reports of each gauge is required.
- 6.3 Aluminum Sign Blanks: Each consignment of aluminum sign blanks is spot checked with a micrometer for gauge thickness conformance. Certificates of Compliance and a Certified Mill Test Report of each gauge are required.

- 6.4 6063 T6 Extruded Aluminum T-Sections (Wind Beam): Certificates of Compliance, Certified Mill Test Reports, and Chemical Analysis are required for each order. No sample is required unless deemed necessary by the Inspector.
- 6.5 HD (High Density) Plywood: The minimum allowable plywood grade shall be B-B high density overlay 60/60 with amber overlay on both sides, and a minimum thickness of 3/4" or as shown on plans. A spot check on thickness requirements, grade-trademark for Grade and Type of plywood, and a letter attesting to the standard of the plywood received is required. No sample is required unless deemed necessary by the Inspector.
- 6.6 Reflective Sheeting: A portion of each roll will be visually inspected for imperfections. A Certificate of Compliance including the type, grade, color, and purchase order number is required for each roll used in the signing fabrication.

*Note 1 –Reflective sheeting from each manufacturer will be sent to the Materials Bureau for reflectivity testing on an annual basis.*

- 6.7 Sign Faces: No sampling is required for reflective or non-reflective sign faces. A visual inspection for conformance and imperfections will be performed on each order of sign faces received. A Certificate of Compliance is required for each shipment. The certificate will include type of material and purchase order number.
- 6.8 Applied or Demountable Copy A Certificate of Compliance is required for each order prior to usage. The reflective sheeting for all sign copies shall be Silver-White No. 2 (Parkway - if a 3M product). Encapsulated lens, wide angle reflective sheeting may be used when specified in the plans.

**7 Fabrication: Items to be observed by the Inspector During Sign Fabrication**

- 7.1 Approved materials.
- 7.2 Visual check of material color and color match with a 150 watt flood light held at eye level at a distance of 50 feet from material being observed.
- 7.3 Visual check of uniform legend color tone and uniform reflectivity with a 150 watt flood light held at eye level at a distance of 50 feet from legend being observed.
- 7.4 Visual check of splices.
- 7.5 Fabrication
  - 7.5.1 Correct thickness of aluminum or plywood.
  - 7.5.2 Correct material for reflectorized and non-reflectorized signs, (sheeting and copy).
  - 7.5.3 Correct "T" sections (wind beam) and proper spacing of "T" sections, (Standard Drawing No. 619-04 and 619-06).
  - 7.5.4 Correct spacing of rivets with heads painted to match signs, (Standard Drawing No. 619-04).



- 7.5.5 Correct spacing of aluminum clips on "T" sections on plywood, (Standard Drawing No. 619-06).
- 7.5.6 Correct sign size, color, and whether copy and background sheeting are reflectorized or non-reflectorized.
- 7.5.7 Corners of control signs rounded.
- 7.5.8 Corners of guide signs rounded when so noted on plans.
- 7.6 Non-Standard Items:
  - 7.6.1 Conformance to contract special provisions. Conformance to special mounting details shown on the plans.

## **8 Application of Materials**

- 8.1 Use of approved equipment and qualified personnel.
- 8.2 Sheeting properly applied.
- 8.3 Absence of foreign particles under applied sheeting.
- 8.4 Absence of air bubbles under applied sheeting.
- 8.5 Absence of loose edges.

## **9 Workmanship**

- 9.1 Correct sign layout and size.
- 9.2 Sharp clear screened sign messages.
- 9.3 Proper horizontal and vertical spacing.
- 9.4 Correctly spelled words.
- 9.5 Symbols correctly depicted.
- 9.6 Back of sign clean and free of corrosion.
- 9.7 Sign number on back of guide signs.

## **10 Design Conformance**

- 10.1 Completed Signs:
  - 10.1.1 All completed signs will conform to the Manual on Uniform Traffic Control Devices, and Standard Highway Signs as specified in the MUTCD, 1978 with addendums; except as may be provided for in the Montana Standard Drawings, Montana Sign Index, or contract plans and approved shop drawings.
  - 10.1.2 All completed signs that are in conformance will be stamped on the back of the sign, by the inspector, with the inspecting agency's stamp of approval.

- 10.1.3 Test reports for signing material, inspected and sampled by a commercial agency, will be sent to the inspecting agency by the Materials Bureau upon completion of the tests.
- 10.1.4 Test reports for material sampled by field personnel will be issued upon completion of the tests.
- 10.1.5 The supplier for all major signing material must provide the manufacturer's Certificates of Compliance. Copies of all certificates will be kept in the Materials Bureau project files.
- 10.1.6 Acceptance reports for material used on pre-inspected signs that were supplied from out-of-state will be submitted to the field in the final report.
- 10.1.7 The field shall provide the Materials Bureau with inspection and acceptance reports whenever un-inspected signing material that has been supplied from out-of-state is delivered to the project. (Section 10.2.4).
- 10.2 Signs Supplied Locally or from Out-of-State:
  - 10.2.1 Signs that have been supplied locally or out-of-state are inspected at the source as designated by the Materials Bureau. Following inspection, a report listing the number and kind of signs will be submitted to the field and to the Materials Bureau.
  - 10.2.2 In the event that the signs have not been pre-inspected, the Materials Bureau shall require a Field Inspection and Acceptance Report in addition to the manufacturer's Certificates of Compliance (Section 10.1.5).
  - 10.2.3 Signs are inspected for conformance with the Montana Department of Transportation specification requirements. Locally inspected signs will bear evidence of having been inspected by the presence of the inspecting agency's stamp of approval. Unpackaged signs will bear a stamp on the back of the sign, while packaged signs will bear a stamp on the package face.
  - 10.2.4 Locally supplied signs that have not been inspected may be delivered to a project only in the case of extreme urgency for installation. For such cases, the suppliers have been directed to immediately forward a letter to the Materials Bureau and to the Project Manager describing the circumstances under which the signs (not inspected) were shipped. This letter must designate the project and location to which the signs were delivered and list the kind and quantity of signs. Signs that have been shipped without inspection shall not be accepted until the manufacturer has submitted this letter.
  - 10.2.5 It is imperative that the Materials Bureau, attention Certification Inspection Supervisor, be informed of the field inspection and acceptance of all signs that do not show evidence of inspection at the source. The following information will be included in this inspection report:
    - 10.2.5.1 Appearance and workmanship
    - 10.2.5.2 Conformance to specifications
    - 10.2.5.3 Type, size, and quantity
    - 10.2.5.4 Gauge of aluminum
    - 10.2.5.5 Thickness or ply of plywood

- 10.3 Final Signing Material and Sign Acceptance Reports:
- 10.3.1 Signing material and signs which have been inspected by a commercial agency will be accepted upon receipt of all required Certificates of Compliance.
  - 10.3.2 Signing material and signs which have been supplied from out-of-state but which have not been inspected will be accepted upon receipt of required certificates from the supplier, a field inspection, and an acceptance report.
  - 10.3.3 Signing material and signs which have been supplied from out-of-state and have been inspected by a commercial agency will be accepted on the reports issued by the agency.
  - 10.3.4 Signing material and signs which have been supplied locally and have been inspected by the District will be accepted on the reports issued by the District.
  - 10.3.5 All signing material and signs, regardless of source and inspection procedure, are subject to final field approval.



**METHODS OF SAMPLING AND TESTING**  
**MT 407-20**  
**METHOD OF TEST FOR HIGH-STRENGTH BOLTS**

**1 Scope**

- 1.1 The method covers rotational capacity testing of high strength bolts used in bridge construction. Two procedures are described in the document:
- 1.1.1 Procedure A – Long Bolts in Tension Calibrator
- 1.1.2 Procedure B – Bolts Too Short for Tension Calibrator

**2 Reference Documents****ASTM**

F3125 High Strength Structural Bolts, Steel and Alloy Steel, Heat Treated, 120 ksi (830 MPa) and 150 ksi (1040 MPa) Minimum Tensile Strength, Inch and Metric Dimensions

**STEEL STRUCTURES TECHNOLOGY CENTER, INC. (AASHTO/FHWA)**

Structural Bolting Handbook

**3 Terminology**

*Test* – Three (3) bolt assemblies per grade, diameter, length, and lot

**PROCEDURE A – LONG BOLTS IN TENSION CALIBRATOR**

**4 Apparatus**

- 4.1 *A Skidmore-Wilhelm calibrator* for measuring bolt tension, of sufficient capacity for the bolts to be tested
- 4.2 *Calibrated torque wrench*
- 4.3 *Spacers and/or washers* with a maximum hole size  $\frac{1}{16}$  in. (2mm) larger than the bolt to be tested
- 4.4 *A steel section* on which to mount the bolt calibrator. The flange of a girder or a cross-frame accessible from the ground is acceptable

**5 Procedure**

- 5.1 Use black fasteners oily to the touch at testing. Ensure all galvanized nuts have a visible dye to verify the presence of the lubricant.

*Note 1 – Weathered and rusty bolts should not be used.*

- 5.2 Measure the bolt length, not including the head.
- 5.3 Install the bolt assembly into the tension measuring device by threading a nut onto the bolt with sufficient spacers to bring the bolt end to at least flush with the tightened nut to a maximum bolt stick-out of three threads. Provide 3 to 5 threads between the inside faces of the nut and the bolt head. Always use a hardened washer under the nut.
- 5.4 Tighten the nut with a wrench to produce the appropriate snug tension from Table 1, with an allowable error range from 0 kips to +2 kips (0 to + 9 kN). The snug condition should be the normal effort applied with a 12-inch wrench.

**Table 1. Maximum Snug Tension**

Bolt Dia. (in.)	Maximum Snug Tension (kips)	
	A325 Bolts	A490 Bolts
1/2	1	1
5/8	2	2
3/4	3	4
7/8	4	5
1	5	6
1 1/8	6	8
1 1/4	8	10
1 3/8	10	12
1 1/2	12	15

Source: ASTM F3125

- 5.5 Matchmark the bolt, nut and face plate of the calibrator with a straight line.
- 5.6 Using the torque wrench, tighten the nut to at least the pretension indicated in Table 2.

**Table 2. Minimum Test Pretension**

Bolt Dia. (in.)	Minimum Test Pretension (kips)	
	A325 Bolts	A490 Bolts
1/2	12	15
5/8	19	24
3/4	28	35
7/8	39	49
1	51	64
1 1/8	64	80
1 1/4	81	102
1 3/8	97	121
1 1/2	118	148

Source: ASTM F3125

Record the bolt tension and the torque that produced the tension. (Measure the torque with the nut in motion).

Calculate the value for maximum allowable torque:

$$T = 0.25 PD$$

where:

T = Maximum permitted torque(ft-lbs)

P = tension in lbs. (N)

D = diameter of bolt in feet (m).

If the recorded torque exceeds the value, T, as calculated above, then the fastener assembly fails the test.

- 5.7 Tighten the nut further by the number of turns shown in Table 3, using the mark on the calibrator faceplate made in Section 5.5 for reference. Record the bolt tension. If bolt and nut assemblies strip or fracture before achieving the full rotation, they have failed the test.

**Table 3. Rotational Turns**

Bolt Length (L) relative to Bolt Diameter (D)	$L \leq 4D$	$4D \leq L \leq 8D$	$8D \leq L$
Required Rotation (turns)	$\frac{2}{3}$	1	$1\frac{1}{6}$

Source: Structural Bolting Handbook

- 5.8 Compare the bolt tension recorded from Section 5.7 with the minimum test tension provided in Table 4. If fastener assemblies do not provide the minimum required tension in Table 4 at the rotation shown in Table 3, the assemblies have failed the test.

**Table 4 Minimum Test Tension**

Bolt Dia. (in.)	Minimum Test Tension (kips)	
	A325 Bolts	A490 Bolts
$\frac{1}{2}$	14	17
$\frac{5}{8}$	22	28
$\frac{3}{4}$	32	40
$\frac{7}{8}$	45	56
1	59	74
$1\frac{1}{8}$	74	92
$1\frac{1}{4}$	94	117
$1\frac{3}{8}$	112	139
$1\frac{1}{2}$	136	170

Source: ASTM F3125

- 5.9 Remove the nut and bolt from the calibrator and examine them. If the fastener assembly threads show signs of stripping, shear or torsion failure or the nut fails to turn freely, by hand, on those threads occupied by the nut in the test position, then the assembly has failed the test.

*Note 2 – The nut does not have to freely turn the entire length of the thread to pass this test.*

- 5.10 Repeat Sections 5.1 to 5.9 until a minimum of two tests have been performed.

**PROCEDURE B – BOLTS TOO SHORT FOR TENSION CALIBRATOR**

**6 Apparatus**

- 6.1 Calibrated torque wrench and hand wrenches.
- 6.2 Spacers and/or washers with a maximum hole size  $\frac{1}{16}$  in. (2mm) larger than the bolt.
- 6.3 A steel section with holes sized  $\frac{1}{16}$  in. (2mm) larger than the bolt diameter, with a plate thickness that will accommodate section 7.3.

**7 Procedure**

- 7.1 Use black fasteners oily to the touch at testing. Ensure all galvanized nuts have a visible dye to verify the presence of the lubricant.

*Note 3 – Weathered and rusty bolts should not be used.*

- 7.2 Measure the bolt length, not including the head.
- 7.3 Install the fastener assembly in the steel plate with sufficient spacers to bring the bolt end out at least flush with the tightened nut, to a maximum bolt stick-out of three threads. Provide three to five threads in the length of bolt between the inside faces of the nut and bolt head. Always use a hardened washer under the nut.
- 7.4 Snug the bolt by applying no more than 20% of the torque allowed in Table 6 below, using a torque wrench. Measure and record the torque (with the nut in motion) on the bolt.
- 7.5 Matchmark the nut, bolt and plate with a straight line.
- 7.6 Tighten the nut with the torque wrench by the number of turns from Table 5. Use a hand wrench to ensure that the bolt does not turn. Measure and record the torque with the nut in motion.

**Table 5. Rotational Turns**

Bolt Length (L) relative to Bolt Diameter (D)	$L \leq 4D$	$4D \leq L \leq 8D$	$8D \leq L$
Required Rotation (turns)	1/3	1/2	2/3

Source: Structural Bolting Handbook

If the measured torque from Section 7.6 exceeds the corresponding value from Table 6, the fastener assembly has failed the test. Assemblies that fail prior to completing this rotation, by stripping or fracture, fail the test.

**Table 6. Maximum Torque at First Rotation**

Bolt Dia. (in.)	Maximum Torque at First Rotation (ft-lbs)	
	A325 Bolts	A490 Bolts
1/2	150	180
5/8	290	370
3/4	500	630
7/8	820	1020
1	1230	1540
1 1/8	1730	2160
1 1/4	2450	3050
1 3/8	3210	3980
1 1/2	4250	5310

Source: ASTM F3125

- 7.7 Further tighten the bolt by turning the nut until the rotation reaches the total rotation listed in Table 7 below, based off the initial reference mark from Section 7.5. Assemblies that fail prior to completing this rotation, by stripping or fracture, fail the test.

**Table 7. Total Rotational Turns**

Bolt Length (L) relative to Bolt Diameter (D)	$L \leq 4D$	$4D \leq L \leq 8D$	$8D \leq L$
Required Rotation (turns)	2/3	1	1-1/6

Source: Structural Bolting Handbook



- 7.8 Remove the nut and the bolt from the plate and examine them. If the fastener assembly threads show signs of stripping, shear or torsion failure or the nut fails to turn freely by hand, on those threads occupied by the nut in the test position, the assembly has failed the test.

*Note 4 – The nut does not have to freely turn the entire length of the thread to pass this test.*

- 7.9 Repeat Sections 7.1 to 7.8 until a minimum of two tests have been performed.

## **8 Report**

- 8.1 Date tested
- 8.2 Name of tester
- 8.3 Procedure performed (A or B)
- 8.4 Assembly and component lot numbers
- 8.5 Testing equipment serial numbers
- 8.6 Testing equipment calibration dates
- 8.7 Bolt length
- 8.8 Bolt tension
- 8.9 Bolt torque at tension



**METHODS OF SAMPLING AND TESTING**  
**MT 408-10**  
**METHOD OF SAMPLING AND FIELD TESTING BRINE DEICING MATERIAL**

**1 Scope**

- 1.1 This method covers the sampling and testing of brine deicing material in the field.

**2 Reference Documents****ASTM**

- D891 Standard Test Methods for Specific Gravity, Apparent, of Liquid Industrial Chemicals  
E126 Standard Test Method for Inspection, Calibration, and Verification of ASTM Hydrometer

**Other Standards**

Clear Roads Document - Clear Roads Snow and Ice Control Chemical Products, Specifications, and Test Protocols (<https://clearroads.org/wp-content/uploads/12-10-Final-CR-SPECS-wCategory4.pdf>).

**3 Terminology**

- 3.1 Deicer – a device or a chemical substance for preventing or removing ice.

**4 Apparatus**

- 4.1 1-gallon jug (NEW, not used) and a label
- 4.2 Hydrometer compliant with ASTM E126 specifications with an appropriate scale that includes the target range
- 4.3 Hydrometer Cylinder
- 4.4 Personal protection equipment (rubber gloves, eye protection, etc)
- 4.5 Deicer sampling checklist

**5 Field Inspection**

- 5.1 Document and maintain records on all deliveries, including those that are rejected.
- 5.2 Check to ensure that the product is being delivered according to the terms of the contract. Document the following information:

Bill of Lading with the following information:

Name of product  
Supplier and manufacturer of product  
Delivery Destination  
Total number of units being delivered  
Total weight of delivery using certified scale tickets or certified flow meter.  
Lot number of product  
Date of the order,  
    Date and time of delivery,  
    Verification of advance delivery notification,  
    Delivered in allowable times,  
    Name of Delivery Company and license plate numbers,

Are any price adjustment assessments required,  
Is the product being delivered what was ordered,  
Document all procedures prior to unloading,  
Verify that all papers required of a delivery are present, complete and legible,  
Legible and current MSDS,  
Certified weight slip.

## **6 Unloading**

- 6.1 Visually inspect the discharge valve prior to unloading for the presence of any foreign material.
- 6.2 Visually inspect the delivered product again while unloading. If problems are noted that are a cause for rejection of the load, immediately halt the unloading process. Take photos and record any pertinent information. Conduct the following procedures if the material is to be rejected.
  - 6.2.1 If the product fails the field inspection or testing, reload the product and reject the load.
  - 6.2.2 If reloading can't be accomplished, (mixed with previous product) note the amount of the product pumped into the tank and total product now in the tank.
  - 6.2.3 Circulate the contents of the tank and then take 2- one gallon (4 liter) samples of the contaminated product now in the tank.
  - 6.2.4 Determine and record the specific gravity of the samples.
  - 6.2.5 Take appropriate action as needed to ensure the integrity of the product on hand if possible. Determine if all products on hand will have to be removed.
  - 6.2.6 Forward all sample directly to MDT's Materials laboratory for testing.
  - 6.2.7 Immediately advise the Purchasing Services Bureau of any ordering, delivery, storage, or product quality issues.

## **7 Sampling**

- 7.1 Remove one gallon of sample from the supplier's truck. Visually inspect the sample and reject the delivery if any foreign material is present.
- 7.2 Purge a minimum of one gallon of product to ensure hoses are free of contamination. Take a one gallon sample from the transfer hose in three equal parts, compositely mixed together, to make up the sample that will be submitted to the laboratory for testing. Collect the samples during unloading as the first third, the second third and the last third of the product is being delivered. If the trailer or pup has compartments, take the three equal samples from only one of the compartments to complete the sample.
- 7.3 Determine the specific gravity of the sample, as described in Section 8. Retain the sample in case of dispute. Dispose of samples after notification by the Purchasing Services Bureau.

## **8 Specific Gravity Determination**

- 8.1 Carefully pour a sufficient quantity of deicer into a clean hydrometer cylinder, taking care to avoid the formation of air bubbles.
- 8.2 Slowly lower the hydrometer in the liquid and release it. After the hydrometer stabilizes and floats freely away from the walls of the cylinder, read the specific gravity at the point the meniscus intersects the hydrometer in accordance to ASTM D891.
- 8.3 Record your results on the Deicer Sampling Checklist.

**Magnesium Liquid Deicer Sampling Checklist**

- 1 Which tank will product be pumped into? \_\_\_\_\_  
 Gallons of de-icer in tank prior to pumping \_\_\_\_\_  
 Gallons after delivery \_\_\_\_\_
  
- 2 Before pumping any material, take a 1-gallon pre-sample. Visually inspect the sample for contamination with foreign material. Determine the specific gravity. Allow pumping to start and dispose of pre-sampled material and go to step 3. Re-sample the material if the sample appears to be contaminated or if it fails the specific gravity. If the second sample appears contaminated or fails the specific gravity, politely inform the delivery driver his product does not meet MDT specification and you must reject the load. If product is rejected immediately contact your supervisor. Retain the second sample for the supervisor.

Specific gravity of pre-sample \_\_\_\_\_

- 3 Choose one compartment from either truck or trailer to take the official sample. Purge a minimum of one gallon of product to ensure hoses are free of contamination. Take a one-gallon sample in three equal parts, compositely mixed together, to make up the sample that will be submitted to the laboratory for testing. Collect the samples during unloading as the first third, the second third and the last third of the product is being delivered. If the trailer or pup has compartments, take the three equal samples from only one of the compartments to complete the sample. Clean the outside of the sample container and attach the label.
  
- 4 Determine the specific gravity of the sample. This must be done in view of the delivery driver.

- 5 Record the following:

Samplers Name: \_\_\_\_\_ Date: \_\_\_\_\_

Time: \_\_\_\_\_ Location: \_\_\_\_\_

Specific Gravity \_\_\_\_\_ Tons of product delivered \_\_\_\_\_

Truck \_\_\_\_\_ or trailer \_\_\_\_\_ # the sample was taken from.

Delivery driver's signature: \_\_\_\_\_



METHODS OF SAMPLING AND TESTING  
MT 409-12  
METHOD OF ACCEPTANCE FOR WELDED STUD SHEAR CONNECTORS  
(MONTANA METHOD)

**THIS PROCEDURE IS IN DEVELOPMENT**





**METHODS OF SAMPLING AND TESTING**  
**MT 412-18**  
**TOPSOIL SAMPLING, SAMPLE PREPARATION, AND TESTING**

**1 Scope**

- 1.1 This procedure of sampling and testing topsoil applies to: 1) topsoil imported from another source (other than the project), and; 2) topsoil intended for use in planting lawns, shrubs, trees or other particular plants (landscaping soil).
- 1.2 Topsoil that has been stripped and is stockpiled on the project site for later placement on median areas, outer separation areas, and side slopes of roadway areas (i.e., salvaging and placing) does not need to be tested.

**2 Referenced Documents****AASHTO**

- R 90 Sampling Aggregate Products
- T 88 Particle Size Analysis of Soils
- T 267 Determination of Organic Content in Soils by Loss on Ignition

**MT Materials Manual**

- MT 232 Soil Corrosion Test

**3 Sampling Procedures**

- 3.1 Samples shall be obtained from each type of soil (homogeneous area). Soil types may be identified from visual appearance or presence of vegetative growth.
  - 3.1.1 Samples of sub-soils may also be taken from borings in conjunction with a subsurface investigation.
  - 3.1.2 Samples from stockpiles or from loaded transports may be taken in accordance with procedures outlined in AASHTO R 90.
- 3.2 Samples from the layer of soil proposed for use as topsoil shall be labeled "topsoil". Samples from the layer of soil over which the topsoil is to be placed shall be labeled "subsoil."
- 3.3 A sample shall be a composite of material from three sampling sites. The sampling sites shall represent similar soils. The sample shall be taken in the following manner.
  - 3.3.1 Dig a v-shaped hole through the thickness of the layer of soil being sampled (if a surface sample) and remove a ½ inch thick slice of soil from one side of it.
  - 3.3.2 Trim off from each side of the slice all but a thin ribbon of soil down the center of the spade face and place in a clean bucket.
  - 3.3.3 Repeat Sections 3.3.1 and 3.3.2 two more times.
  - 3.3.4 Mix thoroughly and keep two pounds (2 lbs) for testing.
- 3.4 Identify the samples by number and the location from which they were taken. Observations concerning the apparent ability of the soil to support plant growth such as the presence or absence of usual or unusual vegetative types, swamps, rock, salt encrustations, etc., should be noted and recorded with the identification data.

**4 Sample Preparation**

- 4.1 Air dry the samples. Remove larger stones by hand and sieve the remainder of the samples through a 10 mesh (2 mm) sieve.
- 4.2 Weigh the material retained on the 10 mesh sieve. Determine the percent by weight and record on the form accompanying the sample(s). This material is considered gravel.
- 4.3 Submit the minus 10 mesh fraction to the Helena Materials Lab for soils testing.

**5 Testing Procedures**

- 5.1 Conductivity – Test topsoil in accordance with [MT 232](#).
- 5.2 Soil pH – Test topsoil in accordance with [MT 232](#).
- 5.3 Organic Matter – Test topsoil in accordance with AASHTO T 267.
- 5.4 Gradation – Test topsoil in accordance with AASHTO T 88.

**METHODS OF SAMPLING AND TESTING**  
**MT 414-23**  
**METHOD OF ACCEPTANCE FOR REINFORCING STEEL**

**1 Scope**

- 1.1 This procedure describes the sampling and acceptance methods for reinforcing steel when random sampling is requested by the Project Manager.
- 1.2 Acceptance of reinforcing steel is based on documentation and sampling (as required or requested).
- 1.3 This method is applicable to carbon-steel and corrosion resistant (i.e., stainless steel and chromium alloyed steel) reinforcing steel.

**2 Referenced Documents****AASHTO**

- M 31 Deformed and Plain Carbon and Low-Alloy Steel Bars for Concrete Reinforcement  
M 334 Uncoated, Corrosion-Resistant, Deformed and Plain Chromium Alloyed, Billet-Steel Bars for Concrete Reinforcement and Dowels

**ASTM**

- A615 Standard Specification for Deformed and Plain Carbon-Steel Bars for Concrete Reinforcement  
A955 Standard Specification for Deformed and Plain Stainless-Steel Bars for Concrete Reinforcement  
A1035 Standard Specification for Deformed and Plain, Low-Carbon, Chromium, Steel Bars for Concrete Reinforcement

**MDT**

- Standard Specifications for Road and Bridge Construction  
Materials Manual of Test Procedures  
MT 601 Materials Sampling, Testing, and Acceptance Guide Index

**3 Required Documents**

- 3.1 For each shipment of reinforcing steel delivered to the project, the contractor shall furnish the required documents specified in Standard Specifications § 555.03.5.
- 3.2 A shipment is defined as the entire quantity of reinforcing bars in each truckload delivered to the project. When reinforcing steel is shipped via rail, a shipment is 20 tons, or a fraction thereof.

**4 Random Sampling**

- 4.1 Corrosion resistant reinforcing steel is to be sampled and tested for acceptance. MDT reserves the right to sample and test carbon-steel reinforcing steel. Reinforcing steel is randomly sampled as requested by the Project Manager. Samples will be taken, at a minimum, following the frequency identified in MT 601. Sampling will be done by the contractor as directed by the Project Manager and witnessed by MDT personnel.

**5 Sample Locations**

- 5.1 The following are locations within the structure where reinforcing steel samples may be taken, or the remaining portion of the sampled bar may be placed, without adverse effect on the structure. The Bridge Bureau must be contacted if clarification is required on the location of any sample bar.

*5.1.1 Footing*

The outermost bar in the mat may be sampled. The portion of the bar remaining shall be centered in the footing and used as is.

5.1.2 *Column*

The bar nearest the centerline of bent at centerline of structure may be sampled. The sample shall be taken from the top end. The remaining portion of the bar may be used as is.

5.1.3 *Slab - Transverse Steel*

Take sample from bar in bottom layer. Center remaining portion of bar between curbs.

5.1.4 *Slab - Longitudinal Steel*

Take sample from any line of bars in bottom of slab adjacent to edge of a beam at the end of slab.

5.1.5 *Curb*

No sample need be taken.

5.1.6 *Bent Cross Beam*

The center bar in bottom layer at bottom of beam may be sampled. Center remaining portion of bar between columns.

5.1.7 *T Type Pier Cap*

The center bar in bottom layer at top of cap may be sampled. Center remaining portion of bar over column.

- 5.2 Forward samples immediately to the Materials Bureau for testing in accordance with AASHTO M 31 or AASHTO M 334.
- 5.3 Keep the sampled shipment separate from the other reinforcing steel shipments on the project until test results have been received.
- 5.4 Reinforcing steel taken for the purpose of sampling may have to be replaced in the structure. When replacement is necessary, it shall be done by the contractor at no cost to MDT.
- 5.5 If re-sampling occurs under Section 6.1 because of a failure, the contractor will need to replace the sampled portion plus the required lap length.

**6 Failing Steel**

- 6.1 In the event that a sample of reinforcing steel fails, two additional (check) samples representing the original sample that failed may be submitted. The check samples must be from the same lot and heat number as the original sample. Both of the check samples must meet specifications before the shipment will be accepted.

*Note: Both check samples must be witnessed by MDT as being from the same lot and heat number as the original sample. Factory samples submitted with the shipment are not acceptable for sample submission.*

- 6.2 If both of the check samples fail, the steel may be rejected in accordance with Section 6.3 or a price reduction may be assessed in accordance with Section 6.4.
- 6.3 MDT may order the failing steel to be removed and replaced at no cost to MDT.

- 6.4 If the Project Manager determines that the steel is usable, a price reduction will be assessed against the contractor. The price reduction will be calculated using the following formula:

$$P = A \times B$$

Where:

- A = total invoice price of reinforcing steel in the lot.\*  
B = 10%, 20% or 30% dependent upon departure from specifications; the value to be used shall be determined by the Project Manager.  
P = Price reduction for the lot.

\* A lot is defined as all of the bars of one bar number and pattern of deformation contained in an individual shipment.

## **7 Standard Weights, Diameters and Number Designations**

- 7.1 The standard weights and diameters of deformed reinforcing bars and their number designations shall be those listed in Table 1.
- 7.1.1 The four minimum yield levels of bars are: 40,000 psi; 60,000 psi; 75,000 psi, and 100,000 psi, designated as Grade 40, Grade 60, Grade 75, and Grade 100, respectively.
- 7.1.2 The nominal dimensions of a deformed bar are equivalent to those of a plain round bar having the same weight per foot as the deformed bar.
- 7.1.3 Bar numbers are based on the number of eighths of an inch included in the nominal diameter of the bars.

**TABLE 1**  
**Rebar Dimension Reference**

Bar Size <sup>a</sup>	Nominal Diameter, In. [mm]	Weight lb/ft [kg/m].
3 [10]	0.375 [9.5]	0.376 [0.560]
4 [13]	0.500 [12.7]	0.668 [0.994]
5 [16]	0.625 [15.69]	1.043 [1.552]
6 [19]	0.750 [19.1]	1.502 [2.235]
7 [22]	0.875 [22.2]	2.044 [3.042]
8 [25]	1.000 [25.4]	2.670 [3.973]
9 [29]	1.128 [28.7]	3.400 [5.060]
10 [32]	1.270 [32.3]	4.303 [6.404]
11 [36]	1.410 [35.8]	5.313 [7.907]
14 [43]	1.693 [43.0]	7.650 [11.38]
18 [57]	2.257 [57.3]	13.600 [20.24]

<sup>a</sup>Bar size is based on the number of eighths of an inch included in the nominal diameter of the bars. [Bar size in metric units.]

**METHODS OF SAMPLING AND TESTING  
MT 415-12  
METHOD OF ACCEPTANCE FOR STRUCTURAL STEEL**

**THIS PROCEDURE IS IN DEVELOPMENT**





**METHODS OF SAMPLING AND TESTING**  
**MT 418-21**  
**METHOD OF ACCEPTANCE FOR MISCELLANEOUS WELDED ITEMS**  
**(Montana Method)**

**1 Scope**

- 1.1 This method describes the procedures for the acceptance of miscellaneous, low stress carrying welded items in the field. It does not cover welding in connection with bridge related items.
- 1.2 Welder certifications and welding specifications must be approved prior to fabrication of the low stress carrying welded item. See Specifications Section 624.03.3 for required submittals.

**2 Referenced Documents*****American Welding Society (AWS)***

D1.1 Structural Welding Code-Steel (current edition)

***Montana Department of Transportation***

Detailed Drawings

Standard Specifications for Road and Bridge Construction

**3 Field Welding Acceptance**

- 3.1 The low stress carrying members listed below can be approved by the field provided the welding has been done by a certified welder in accordance with AWS D1.1. In the event that field welding is necessary, welder certifications shall be verified prior to welding. If welder certification tests are needed, contact the Materials Bureau.
- Trash guard racks (MDT Detailed Drawing No. 615-02)
  - Median inlet covers (MDT Detailed Drawing No. 604-00)
  - Concrete barrier rail anchors (MDT Detailed Drawing No. 605-05)
  - Intersecting roadway terminal section (MDT Detailed Drawing No. 606-46)
  - Box beam to MGS Transition (MDT Detailed Drawing No. 606-58)
  - Low tension cable guardrail (MDT Detailed Drawing No. 606-94)
  - Box Beam Guardrail (MDT Detailed Drawing No. 606-97, 609-98, and 609-99)
  - Heavy duty cattle guard (MDT Detailed Drawing No. 611-00)
  - Cattle guard hinged grate (MDT Detailed Drawing No. 611-03)
  - Ladders, stairways, scale pit angles, grates, and miscellaneous items associated with weigh stations, rest areas, and observation points.
- 3.2 In accordance with MDT Standard Specifications 106.09, the low stress carrying welded items must be accompanied by a [Form 406](#) and a certification from the final manufacturer or prefabrication plant indicating that all steel incorporated has been melted/recycled and manufactured in the United States.
- 3.3 A visual inspection report signed by a Certified Welding Inspector must be submitted with the material.
- 3.4 The items must be visually inspected per the requirements of the AWS D1.1.



**METHODS OF SAMPLING AND TESTING**  
**MT 420-04**  
**PROCEDURE TO CHECK FOR LEAKS UNDER HYDROSTATIC PRESSURE**

**1 Scope**

- 1.1 This procedure is used to determine the degree of water tightness for corrugated metal irrigation or siphon pipe and couplers. This test is customarily performed at the fabrication plant, but can also be performed in the field.

**2 Apparatus and Equipment**

- 2.1 Bulkheads shall consist of the following:
- 2.1.1 A two-foot section of corrugated steel pipe of the specific diameter to be tested. Pipe sections with helical corrugations shall be re-rolled at the outer ends to form at least two corrugations to fully accommodate band couplers.
  - 2.1.2 Two squares pieces of 1/8 inch thick steel plate, with a dimension four inches greater than the diameter of the pipes to be tested.
  - 2.1.3 Four lengths of 2 inch x 2 inch x ¼ inch steel angles to be used as braces with a length equal to the dimension of the plates.
  - 2.1.4 One – 3 inch galvanized steel elbow.
  - 2.1.5 One – 3 inch galvanized cap with a ¾ inch threaded hole at center.
  - 2.1.6 One – ¾ inch, or longer, gate valve to accommodate a water hose.
  - 2.1.7 Two full length section of culvert.
  - 2.1.8 Three approved band couplers with appropriate gaskets.
  - 2.1.9 2 inch x 4 inch wood bracing blocks 3 feet in length.
- 2.2 The bulkheads consist of two 2-foot sections of corrugated steel pipe, of the diameter of the pipe to be tested, to which a braced 1/8 inch square plate has been welded to one end. One bulkhead is fitted with a 3 inch galvanized elbow. The elbow is welded vertically to the top of the plate. The horizontal leg of the elbow must be located directly below the trough of the culvert corrugation to prevent air entrapment (See Figure 1).
- 2.3 A 3 inch removable, galvanized filler cap with ¾ inch dia. hole at center is to accommodate a standpipe for observing the static pressure head applied (see Figure 1 & Figure 2).
- 2.4 A ¾ inch dia. Gate valve is to accommodate the pressurized hose attached to the bottom of the steel back plate. This valve is to provide a constant head of water in the stand pipe during the tests and also to serve as a drain after testing is completed (see Figure 1).
- 2.5 The stand pipe shall consist of the following:
- 2.5.1 Four – 5 foot sections of ¾ inch galvanized pipe.
  - 2.5.2 Three – ¾ inch galvanized tees.
  - 2.5.3 Three – ¾ inch galvanized plugs.
  - 2.5.4 One – 8 inch funnel.

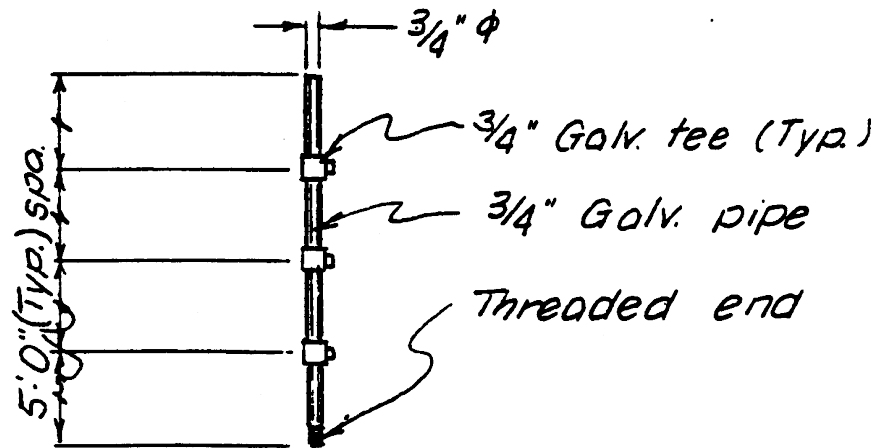
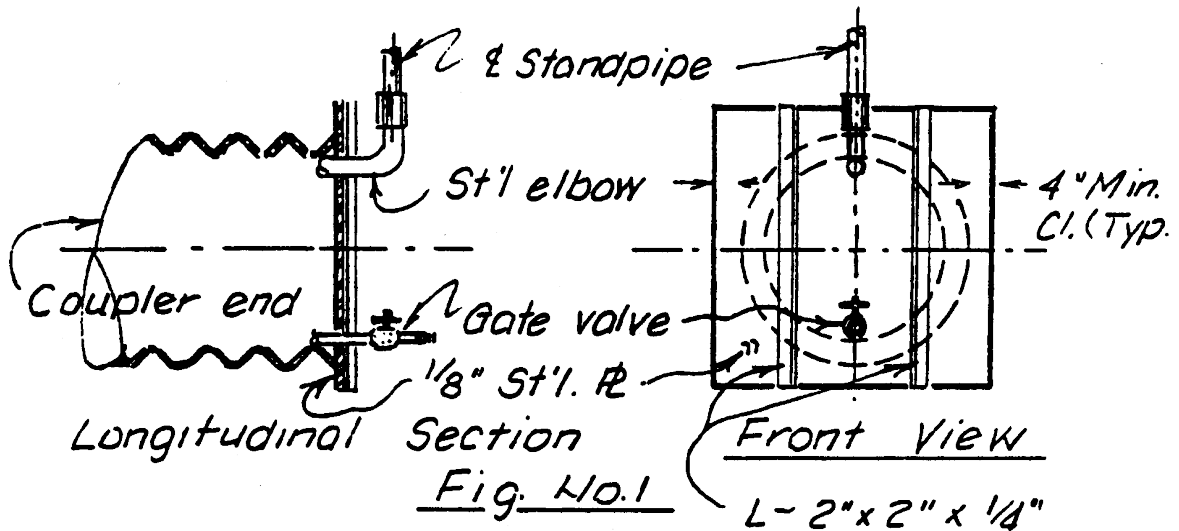

**3 Procedure**

- 3.1 After attaching the bulkheads to the culvert test sections, the sections are coupled together, braced at the center to prevent sagging, and are filled to capacity with water.
- 3.2 The 20 foot stand pipe (Figure 2) is assembled and attached to the 3 inch elbow filler cap.
- 3.3 Water is introduced into the stand pipe from the bottom by means of the gate valve.
- 3.4 With water flowing continuously out of the first or bottom tee, and after waiting for a period of five minutes, a close examination is made of the test section for evidence of leakage.
- 3.5 The tee is plugged and the process repeated at each five foot increment until water flows out of the top of the stand pipe, the maximum twenty foot head.
- 3.6 A slight indication of "sweating" or "seepage" at the test seams is permissible for irrigation pipe. Dripping or free flow of water is not acceptable. No sweating or other seepage for siphon pipe applications is permissible. If only the pipe seams are being tested but not the bands, some leakage at the bands may be allowed.

**4 Frequency of Test**

- 4.1 Each diameter of pipe at least once a year at the discretion of the inspector.



**METHODS OF SAMPLING AND TESTING**  
**MT 422-12**  
**METHOD OF TEST FOR SURFACE SMOOTHNESS AND PROFILE**

**1 Scope**

- 1.1 This method covers the testing of a finished flexible pavement surface for smoothness and profile. The surface smoothness is expressed in International Roughness Index (IRI) in units of inches per mile. The surface profile is generated to locate variations in profile (e.g., bumps or dips). This method is not intended to be used with rigid pavement or gravel surfacing.

**2 Reference Documents**

Operator's Manual, Surface Systems & Instruments, LLC

Profiler Operations Manual (POM) for MDT Profilers (most recent version)

MDT QC/QA Plan (most recent version)

**3 Terminology**

- 3.1 *International Roughness Index (IRI)* – An index resulting from a mathematical simulation of vehicular response to the longitudinal profile of a pavement using a 'quarter-car' simulation model as described in NCHRP Report 228.

**4 Apparatus**

- 4.1 Class I laser road profiler as defined in ASTM E950. The road profiling system is mounted on a vehicle, usually a van or truck. It consists of the following components:
- 4.1.1 Vertical, non-contact, height measurement systems (i.e., laser) capable of measuring the height from the mounted sensor face to the surface of the pavement.
- A linear distance measuring system (i.e., DMI) capable of measuring distance traveled.
- 4.1.3 An inertial referencing system (i.e., accelerometers) capable of measuring the movement of the vehicle as it traverses the pavement.

**5 Software**

- 5.1 The software must activate the testing using parameters (i.e., data collection initiation) that are stored by the control setup.
- 5.2 The software must receive, display, and store raw data received from the profiler.
- 5.3 The software must be capable of accumulating desired output and printing results.

**6 Calibration**

- 6.1 Perform a comprehensive calibration and sensor check at thirty (30) day intervals during construction season. Check the DMI and verify Laser each day before use.
- 6.2 Calibration is used to establish and adjust the operating characteristics of the SSI system. There are five (5) items that will either be calibrated or checked: laser height, distance measuring device, tire pressure, Accelerometer and Bounce Test.
- 6.3 Check tire pressure and inflate to manufacturer's recommended psi. Special care should be given to the tire on which the DMI device is mounted.

- 6.4 Laser Height Verification
  - 6.4.1 The lasers have been calibrated at the factory. The lasers can only be verified.
  - 6.4.2 A verification check of the laser will be performed each day before use.
  - 6.4.3 A full verification check of the laser sensors must also be performed whenever problems are suspected, or when a sensor is repaired or replaced.
- 6.5 Facility for Laser Height Verification
  - 6.5.1 Each MDT District should have a facility available (e.g.; enclosed garage at District).
  - 6.5.2 Facility should have a level surface and be free of vibration.
- 6.6 Procedure for Laser Height Verification
  - 6.6.1 Verify laser height in accordance with section 3.3 (pages 15-16) of the SSI Operations Manual.
- 6.7 Accelerometers
  - 6.7.1 Accelerometers need an occasional static verification. Perform static verification (1) every 30 days during times when the system is used frequently, (2) after any prolonged period that the system has not been used, (3) when repairs are performed on the accelerometer(s) or associated system, or (4) any time the system is generating data that appears erroneous or suspect.
- 6.8 Facility for Accelerometer Verification
  - 6.8.1 Each MDT District should have a facility available (e.g.; enclosed Garage at District).
  - 6.8.2 Facility should have a level surface and be free of vibration.
- 6.9 Procedure for Accelerometer Verification
  - 6.9.1 Perform the Accelerometer verification as per section 3.6 (page 21) of the SSI Operations Manual.
- 6.10 Bounce Test
  - 6.10.1 The bounce test is a controlled-conditions procedure that uses the profiler's built-in simulation capabilities to test that the profiling system is operating properly. Perform the bounce test (1) every 30 days during times when the system is used frequently, (2) after any prolonged period that the system has not been used, (3) when repairs are performed on the associated system, or (4) any time the system is generating data that appears erroneous or suspect.
- 6.11 Facility for Bounce Test
  - 6.11.1 Each MDT District should have a facility available (e.g.; enclosed garage at District).
  - 6.11.2 Facility should have a level surface and be free of vibration.
- 6.12 Procedure for Bounce Test
  - 6.12.1 Perform the Bounce Test as per sections 3.4 and 3.5 (page 17) of the SSI Operations Manual.
- 6.13 Distance Measuring Instrument (DMI)
  - 6.13.1 Calibrate DMI whenever problems are suspected, the tires are replaced, suspension repairs are performed, wheels are rotated/ aligned, or repairs are performed on the DMI.



6.14 DMI Calibration Site

6.14.1 Each MDT District should have a calibration site established.

6.14.2 This site should be located on a straight portion of roadway that is reasonably level and has low traffic volume.

6.14.3 The site should be measured with a standard surveying tape or wheel (using standard surveying procedures), or laid out using an electronic distance measuring system.

6.15 Procedure for DMI Calibration

6.15.1 Calibrate the Distance Measuring Instrument (DMI) as per section 3.2 (pages 14-15) of the SSI Operations Manual.

6.16 Record Keeping

6.16.1 SSI software has a Calibration/Verification Report that Tracks DMI Calibration and Accelerometer Verification dates. That report may be printed from any Data Analysis files you may have. A simple record of all calibrations and verifications can be kept with the machine as per attached. (SEE "Calibration and Run Information" form)

**7 Project Testing**

7.1 Preparation of Surface

7.1.1 Test the roadway only when it is free of moisture and any deleterious material that will not provide accurate test results.

7.1.2 The Contractor is responsible for all work to prepare the roadway for testing, such as, but not limited to sweeping off of debris.

7.1.3 Do not conduct testing while it is raining or under other weather conditions determined inclement by the Engineering Project Manager (EPM).

7.2 Project Setup

7.2.1 Engineering Project Manager (EPM) or one of his/her representatives will meet with the Contractor and identify the Beginning-of-Project (BOP), the End-of-Project (EOP), and all excluded areas (e.g., bridges not paved, curves with short radii).

7.2.2 If possible, project should be marked for testing using reflective tape or reflective traffic cones. This is the preferred method. There are two other acceptable methods: back-up to start or manual.

7.2.3 If it is not feasible to use the photocell to initiate and stop data collection, data collection can be initiated and stopped manually. When manually initiating and stopping profile data collection, cones should be placed at the beginning and end of the project to be used as reference points by the operator.

### 7.3 Profiler Operations

7.3.1 Operation of profiler should be consistent with guidelines discussed in the latest version of the SSI Profiler Operations Manual. This includes but is not limited to the following:

- Run in English unit system.
- If possible, initiate data collection via reflective surface and photocell.
- Use approved file naming convention. (Contract#\_Lane Direction\_Lane\_Run#) example 09610\_NB\_DR\_Run1
- Document any issues that occurred during testing.
- Process data with software.
- Properly backup data.
- Provide report to EPM or one of his/her representatives.

7.3.2 MDT collects two comparable runs.

- Once the operator is confident that a minimum of two comparable runs have been obtained, the Quality Control Review and Bump Reports are used to evaluate their acceptability. Profiler runs should satisfy the following criteria:
- The average IRI values at each 1 mi (1.61 km) interval for each of the two runs are within  $\pm 5.7\%$  of the mean IRI of both runs.
- If spikes (e.g., unusually high IRI) are present in the data, the operator should determine if spikes are pavement related or the result of equipment or operator error. The operator should examine the profile bump reports for discrepancies and features that cannot be explained by observed pavement features.
- Rerun the entire project if any one mile section does not match within the 5.7% tolerance established above (bullet #2) and compare that run to the previous runs.
- Use the results of the two runs that compare for project acceptance.
- If the third run does not compare to either of the first two runs, recheck all calibrations and then rerun the entire project and compare the results to the previous runs. Use the two runs that compare favorably.

### 7.4 Testing Results

7.4.1 Results shall be provided to EPM or one of his/her representatives and shall be processed into desired segments (e.g., 0.5 miles) as described in the contract Ride Specification.

7.4.2 A Roughness Report will be generated for the first profile run deemed to be within the comparison values for each lane profiled. This report will contain the IRI values for the left and right wheel paths. These IRI values will be applied to the most recent pay incentives/disincentives as described in Ride Specification.

7.4.3 A Bump Report will be generated for the first profile run deemed to be error free for each lane profiled. The Bump Report will indicate the locations of potential defects. These will be reviewed with the EPM. Location should be physically examined to determine if, at the EPM's discretion, the location should be considered a defect.