

ARCH PIPE

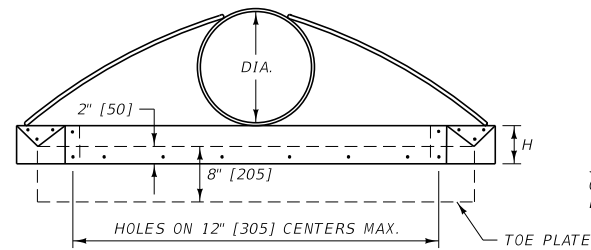

ROUND PIPE

CONNECTIONS

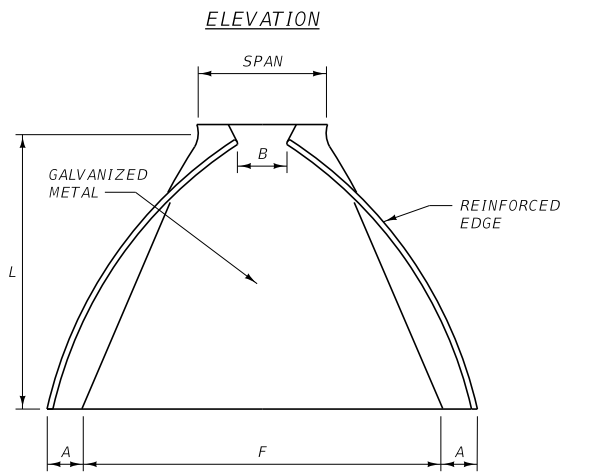

ELEVATION

PLAN

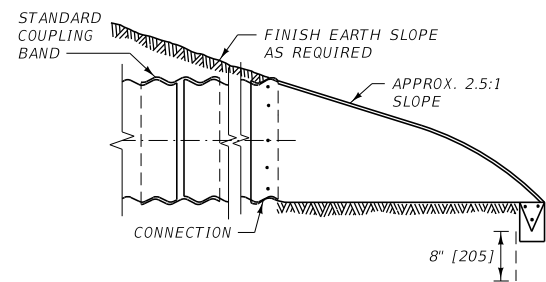

TYPICAL CROSS-SECTION
(ILLUSTRATED WITH TYPE 3 CONNECTION)

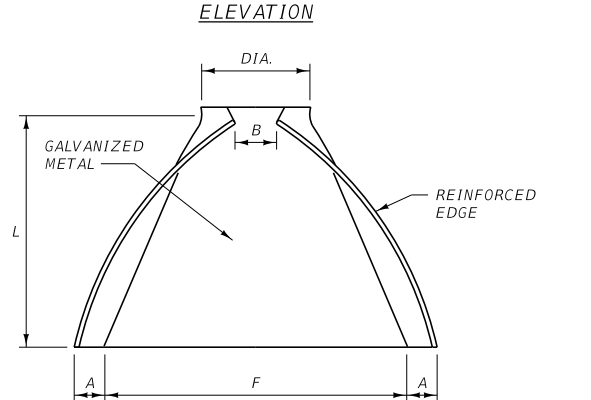

ELEVATION

PLAN

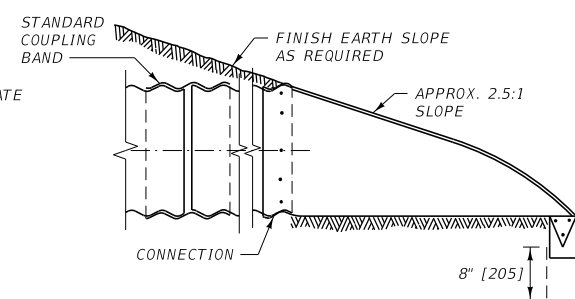

TYPICAL CROSS-SECTION
(ILLUSTRATED WITH TYPE 3 CONNECTION)

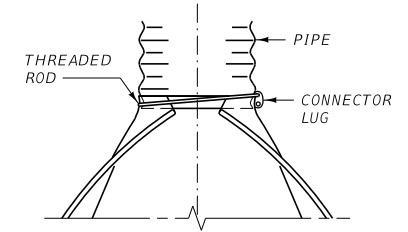

TYPE 1

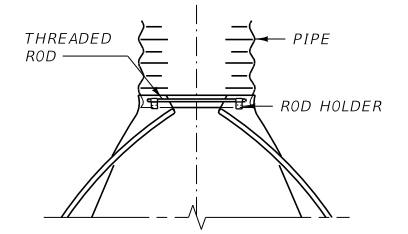

TYPE 2

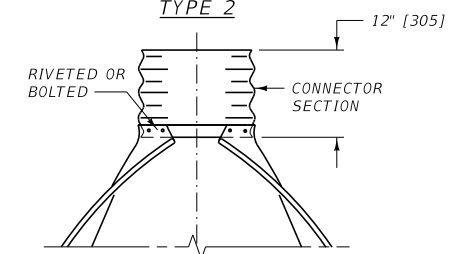

TYPE 3

DIMENSION TABLE

EQUIVALENT DIAMETER	3" x 1" CORR. SPAN x RISE	MINIMUM THICKNESS *	2 2/3" x 1/2" CORR. SPAN x RISE	MINIMUM THICKNESS *	DIMENSIONS					TYPE CONNECTOR
					A 1" TOL.	B MAX.	H 1" TOL.	L 1 1/2" TOL.	F 2" TOL.	
18"			21" x 15"	0.064"	7"	10"	6"	23"	36"	2
24"			28" x 20"	0.064"	9"	14"	6"	32"	48"	2
30"			35" x 24"	0.079"	10"	16"	6"	39"	60"	2
36"			42" x 29"	0.079"	12"	18"	8"	46"	75"	3
42"			49" x 33"	0.109"	13"	21"	9"	53"	85"	3
48"	53" x 41"	0.109"	57" x 38"	0.109"	18"	26"	12"	63"	90"	3
54"	60" x 46"	0.109"	64" x 43"	0.109"	18"	30"	12"	70"	102"	3
60"	66" x 51"	0.109"	71" x 47"	0.109"	18"	33"	12"	77"	114"	3
66"	73" x 55"	0.109"	77" x 52"	0.109"	18"	36"	12"	77"	126"	3
72"	81" x 59"	0.109"	83" x 57"	0.109"	18"	39"	12"	77"	138"	3

DIMENSION TABLE

PIPE DIA.	MINIMUM THICKNESS *	DIMENSIONS					TYPE CONNECTOR
		A 1" TOL.	B MAX.	H 1" TOL.	L 1 1/2" TOL.	F 2" TOL.	
12"	0.064"	6"	6"	6"	21"	24"	1
15"	0.064"	7"	8"	6"	26"	30"	1
18"	0.064"	8"	10"	6"	31"	36"	1
21"	0.064"	9"	12"	6"	36"	42"	1
24"	0.064"	10"	13"	6"	41"	48"	1
30"	0.079"	12"	16"	8"	51"	60"	2
36"	0.079"	14"	19"	9"	60"	72"	2
42"	0.109"	16"	22"	11"	69"	84"	3
48"	0.109"	18"	27"	12"	78"	90"	3
54"	0.109"	18"	30"	12"	84"	102"	3
60"	0.109"	18"	33"	12"	87"	114"	3
66"	0.109"	18"	36"	12"	87"	120"	3
72"	0.109"	18"	39"	12"	87"	126"	3
78"	0.109"	18"	42"	12"	87"	132"	3
84"	0.109"	18"	45"	12"	87"	138"	3

NOTES:

- ① PROVIDE TOE PLATE WHEN SPECIFIED.
- ② GALVANIZE ALL PARTS PER SECTION 711.
- ③ PAINT ANY AREAS WHERE GALVANIZING IS BROKEN OR METAL IS BARE WITH ONE COAT OF ZINC RICH PAINT AND TWO COATS OF ALUMINUM PAINT PER SECTION 710.
- ④ MINOR VARIATIONS IN DESIGN MAY BE ACCEPTABLE ON APPROVAL OF THE PROJECT MANAGER.
- ⑤ SEAMS OR JOINTS LENGTHWISE OF THE APRON ARE ACCEPTABLE IF SECURELY BOLTED OR WELDED AND PAINTED AS PROVIDED ABOVE.

* THICKNESSES SHOWN ARE FOR STEEL CULVERTS. FOR THICKNESS OF ALUMINUM, SUBTRACT 0.004" [0.10 mm].

METRIC DIMENSION TABLE

EQUIVALENT DIAMETER (mm)	SPAN x RISE (mm)	MINIMUM THICKNESS (mm) *	DIMENSIONS (mm)					APPROX. SLOPE	TYPE CONNECTOR
			A 25 TOL.	B MAX.	H 25 TOL.	L 40 TOL.	F 50 TOL.		
68 x 13 CORRUGATIONS									
450	530 x 380	1.63	150	280	150	610	860	2:1	2
600	710 x 510	1.63	180	410	150	810	1170	2:1	2
750	885 x 610	2.01	230	410	150	990	1470	1.88:1	2
900	1060 x 740	2.01	280	460	180	1170	1850	1.88:1	3
1050	1240 x 840	2.77	300	530	230	1350	2080	1.75:1	3
1200	1440 x 970	2.77	410	660	300	1570	2240	1.88:1	3
1350	1620 x 1100	2.77	430	760	300	1750	2540	1.88:1	3
1500	1800 x 1200	2.77	430	910	300	1960	2840	1.88:1	3
1650	1950 x 1320	2.77	430	910	300	1960	3150	1.63:1	3
1800	2100 x 1450	2.77	430	1120	300	1960	3300	1.5:1	3
75 x 25 CORRUGATIONS									
1200	1340 x 1050	2.77	430	660	300	1600	2240	1.75:1	3
1350	1520 x 1350	2.77	430	910	300	1780	2540	1.88:1	3
1500	1670 x 1300	2.77	430	910	300	1960	2840	1.75:1	3
1650	1850 x 1400	2.77	430	910	300	1960	3150	1.5:1	3
1800	2050 x 1500	2.77	430	1120	300	1960	3450	1.63:1	3

METRIC DIMENSION TABLE

PIPE DIA. (mm)	MINIMUM THICKNESS (mm) *	DIMENSIONS (mm)					APPROX. SLOPE	TYPE CONNECTOR
		A 25 TOL.	B MAX.	H 25 TOL.	L 40 TOL.	F 50 TOL.		
300	1.63	125	180	150	535	560	2.25:1	1
375	1.63	150	205	150	660	710	2.25:1	1
450	1.63	180	255	150	785	865	2.13:1	1
525	1.63	205	305	150	915	1015	2.13:1	1
600	1.63	230	330	150	1040	1170	2.13:1	1
750	2.01	280	405	205	1295	1395	2.13:1	2
900	2.01	330	485	230	1525	1780	2:1	2
1050	2.77	380	635	255	1755	2085	2.13:1	3
1200	2.77	430	735	305	1980	2235	2:1	3
1350	2.77	430	840	305	2135	2540	2:1	3
1500	2.77	430	915	305	2210	2845	1.88:1	3
1650	2.77	430	990	305	2210	2995	1.63:1	3
1800	2.77	430	1120	305	2210	3050	1.5:1	3
1950	2.77	430	1220	305	2210	3300	1.38:1	3
2100	2.77	430	1320	305	2210	3455	1.33:1	3

UNITS SHOWN IN BRACKETS [] ARE METRIC AND ARE IN MILLIMETERS (mm) UNLESS OTHER UNITS ARE SHOWN.

DETAILED DRAWING	
REFERENCE STANDARD SPEC. SECTION 603.709,710,711	DWG. NO. 603-02
CMP FLARED END TERMINAL SECTION (FETS)	
MDT MONTANA DEPARTMENT OF TRANSPORTATION	

TYPE "A"

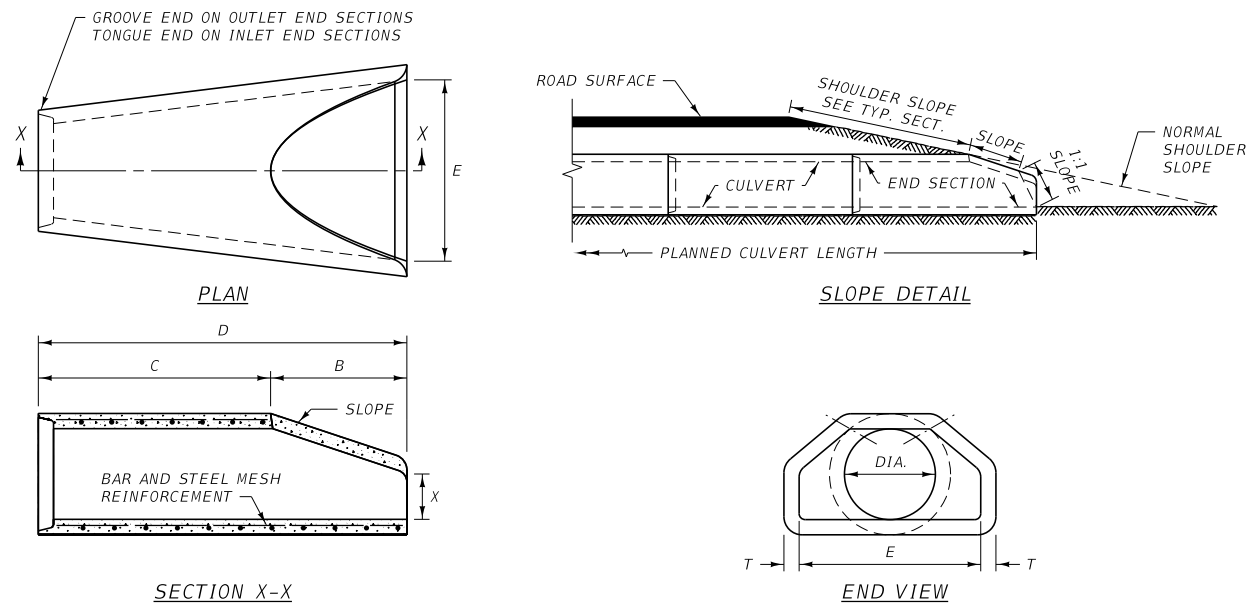

TYPE "A"							
DIA.	SLOPE	X	B	C	D	E	T *
12"	2.4:1	4"	2'-0"	4'-0"	6'-0"	2'-0"	2"
15"	2.4:1	6"	2'-3"	3'-9"	6'-0"	2'-6"	2 1/4"
18"	2.3:1	9"	2'-3"	3'-9"	6'-0"	3'-0"	2 1/2"
24"	2.5:1	9 1/2"	3'-7 1/2"	2'-4 1/2"	6'-0"	4'-0"	3"
30"	2.5:1	1'-0"	4'-6"	1'-6"	6'-0"	5'-0"	3 1/2"
36"	2.5:1	1'-3"	5'-3"	2'-11"	8'-2"	6'-0"	4"
42"	2.5:1	1'-9"	5'-3"	2'-11"	8'-2"	6'-6"	4 1/2"
48"	2.5:1	2'-0"	6'-0"	2'-2"	8'-2"	7'-0"	5"
54"	2.0:1	2'-3"	5'-5"	2'-9 1/2"	8'-2 1/2"	7'-6"	5 1/2"

* WALL "B" THICKNESS

TOLERANCES IN THE ADJACENT TABLES MAY NOT VARY MORE THAN ±1.5% FOR THE DIMENSIONS SHOWN. OTHERWISE THEY MUST CONFORM TO AASHTO M 170.

TYPE "B"

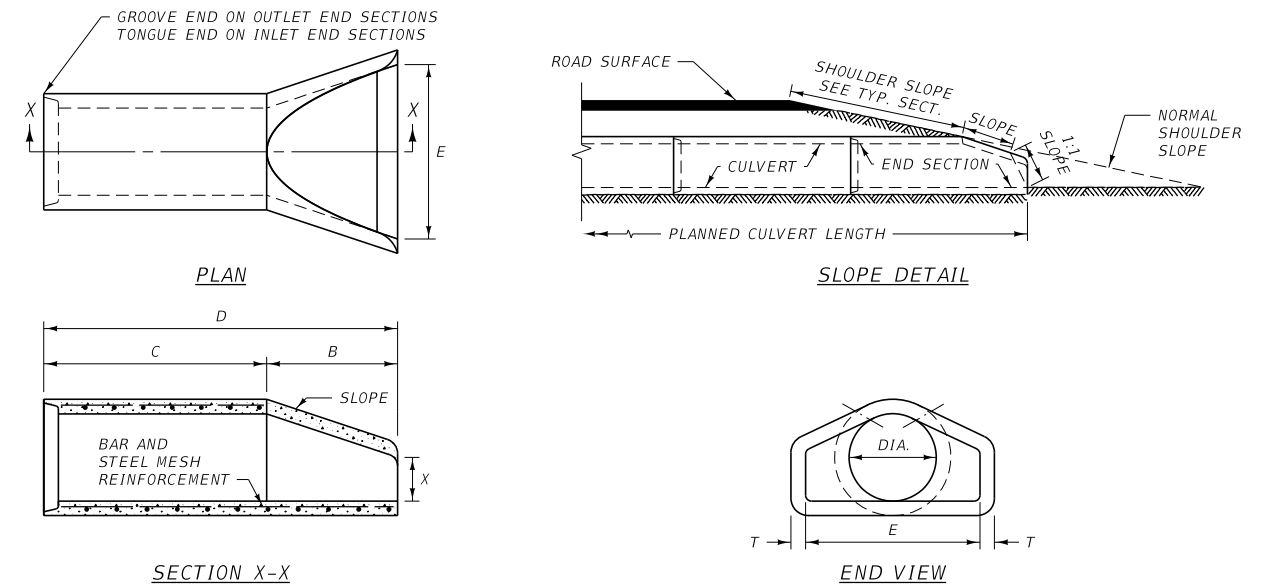

TYPE "B"							
DIA.	SLOPE	X	B	C	D	E	T *
12"	2.4:1	4"	2'-0"	4'-0"	6'-0"	2'-0"	2"
15"	2.4:1	6"	2'-3"	3'-9"	6'-0"	2'-6"	2 1/4"
18"	2.3:1	9"	2'-3"	3'-9"	6'-0"	3'-0"	2 1/2"
24"	2.5:1	9 1/2"	3'-7 1/2"	2'-4 1/2"	6'-0"	4'-0"	3"
30"	2.5:1	1'-0"	4'-6"	1'-6"	6'-0"	5'-0"	3 1/2"
36"	2.5:1	1'-3"	5'-3"	2'-11"	8'-2"	6'-0"	4"
42"	2.5:1	1'-9"	5'-3"	2'-11"	8'-2"	6'-6"	4 1/2"
48"	2.5:1	2'-0"	6'-0"	2'-2"	8'-2"	7'-0"	5"
54"	2.0:1	2'-3"	5'-5"	2'-9 1/2"	8'-2 1/2"	7'-6"	5 1/2"

* WALL "B" THICKNESS

LARGE DIAMETER PIPE

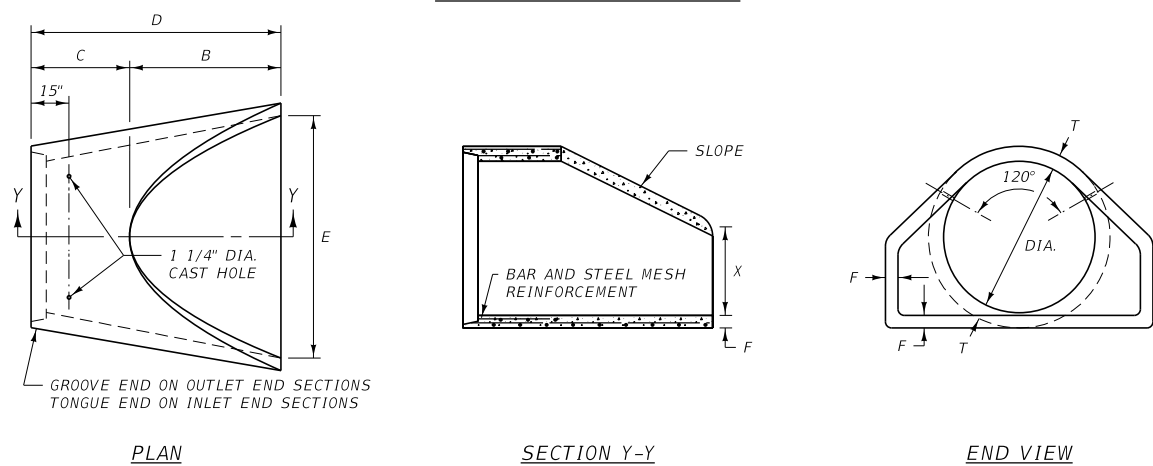

LARGE DIAMETER CULVERT								
DIA.	SLOPE	T *	X	B	C	D	E	F
60"	1.9:1	6"	2'-11"	5'-0"	3'-3"	8'-3"	8'-0"	5"
66"	1.7:1	6 1/2"	2'-6"	6'-0"	2'-3"	8'-3"	8'-6"	5 1/2"
72"	1.9:1	7"	3'-0"	6'-6"	1'-9"	8'-3"	9'-0"	6"
78"	1.8:1	7 1/2"	3'-0"	7'-6"	1'-9"	9'-3"	9'-6"	6 1/2"
84"	1.5:1	8"	3'-0"	7'-6 1/2"	1'-9"	9'-3 1/2"	10'-0"	6 1/2"
90"	1.5:1	8 1/2"	3'-5"	7'-3 1/2"	2'-0"	9'-3 1/2"	11'-0"	6 1/2"

* WALL "B" THICKNESS

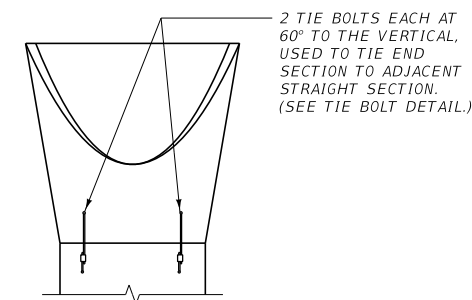

TIE BOLT CONNECTION

TIE BOLTS: USE TWO TIE BOLTS ON ALL FLARED END SECTIONS, ONE ON EACH SIDE AT 60° TO THE VERTICAL. GALVANIZE ALL PARTS. SEE TIE BOLT DETAIL.

CONSTRUCTION: CONSTRUCT PER SECTION 708.

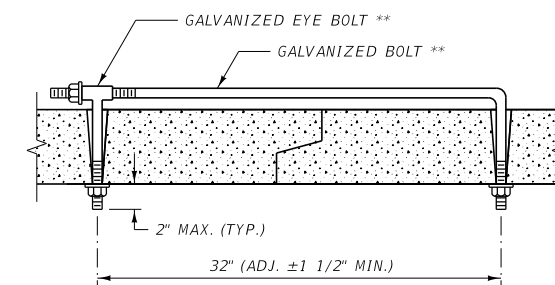

TIE BOLT DETAIL
(TWO PER END SECTION)

** 3/4" FOR 12" TO 54" DIA. RCP
1" FOR 60" TO 90" DIA. RCP

DETAILED DRAWING	
REFERENCE STANDARD SPEC. SECTION 603.708	DWG. NO. 603-08
PREFABRICATED RCP FLARED END TERMINAL SECTION (FETS)	
MDT MONTANA DEPARTMENT OF TRANSPORTATION	

TYPE "A"

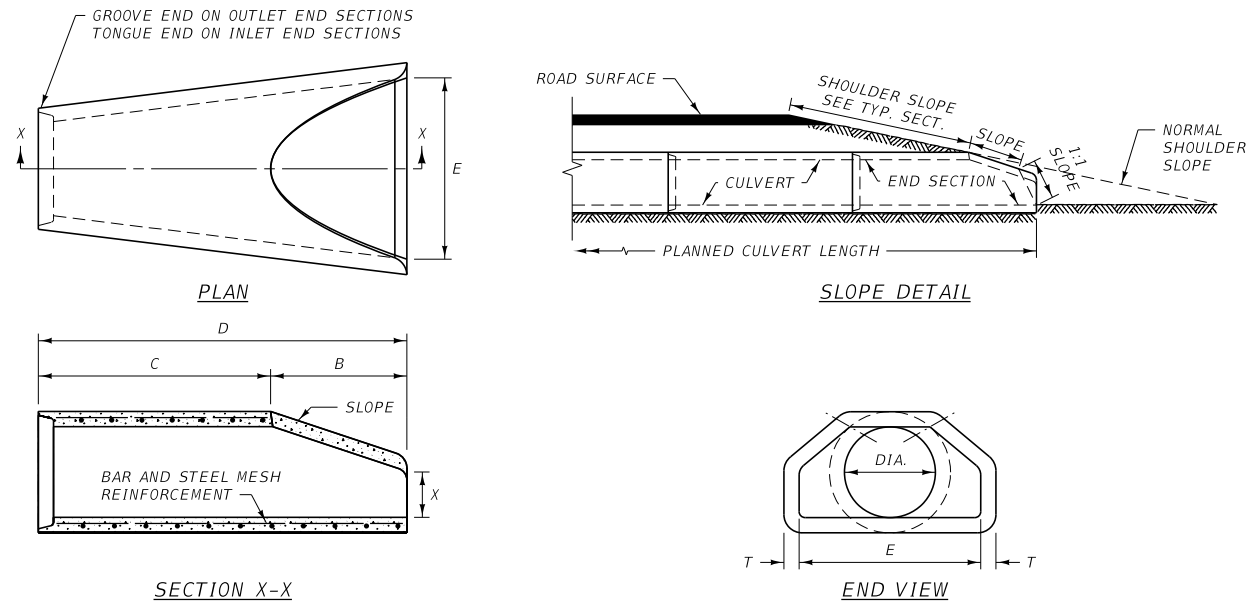

TYPE "B"

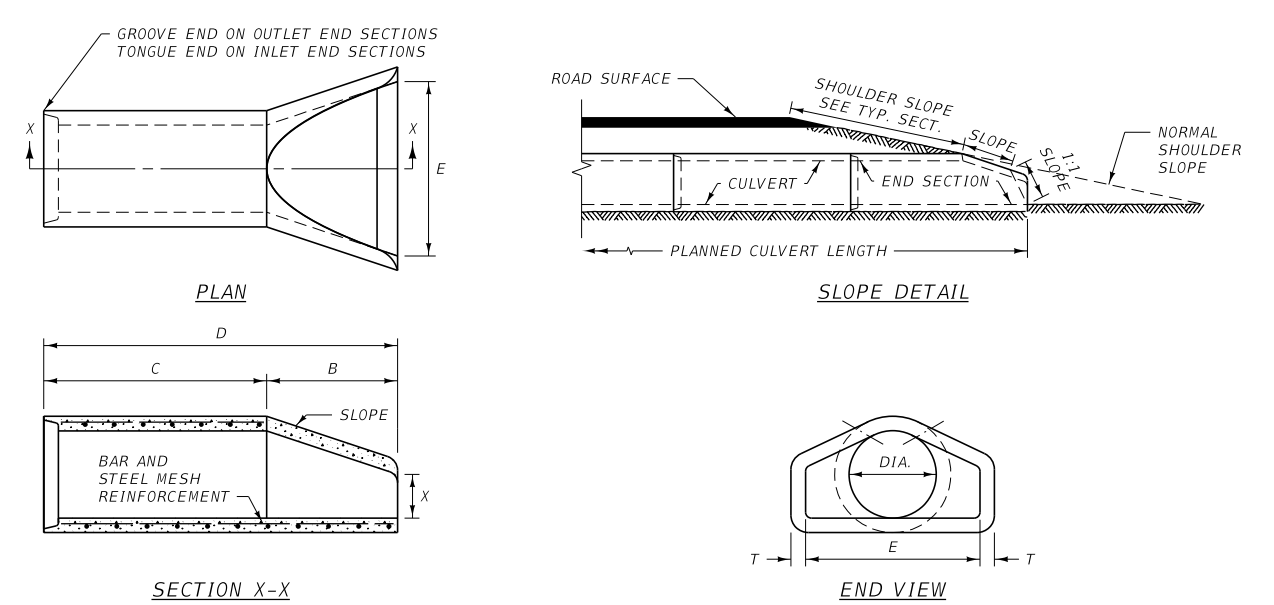

TYPE "A"							
DIA.	SLOPE	X	B	C	D	E	T *
300	2.4:1	101.6	609.6	1219.2	1828.8	609.6	50.8
375	2.4:1	152.4	685.8	1143.0	1828.8	762.0	57.2
450	2.3:1	228.6	685.8	1143.0	1828.8	914.4	63.5
600	2.5:1	241.3	1104.9	723.9	1828.8	1219.2	76.2
750	2.5:1	304.8	1371.6	457.2	1828.8	1524.0	88.9
900	2.5:1	381.0	1600.2	889.0	2489.2	1828.8	101.6
1050	2.5:1	533.4	1600.2	889.0	2489.2	1981.2	114.3
1200	2.5:1	609.6	1828.8	660.4	2489.2	2133.6	127.0
1350	2.0:1	685.8	1651.0	850.9	2501.9	2286.0	139.7

TYPE "B"							
DIA.	SLOPE	X	B	C	D	E	T *
300	2.4:1	101.6	609.6	1219.2	1828.8	609.6	50.8
375	2.4:1	152.4	685.8	1143.0	1828.8	762.0	57.2
450	2.3:1	228.6	685.8	1143.0	1828.8	914.4	63.5
600	2.5:1	241.3	1104.9	723.9	1828.8	1219.2	76.2
750	2.5:1	304.8	1371.6	457.2	1828.8	1524.0	88.9
900	2.5:1	381.0	1600.2	889.0	2489.2	1828.8	101.6
1050	2.5:1	533.4	1600.2	889.0	2489.2	1981.2	114.3
1200	2.5:1	609.6	1828.8	660.4	2489.2	2133.6	127.0
1350	2.0:1	685.8	1651.0	850.9	2501.9	2286.0	139.7

TOLERANCES IN THE ADJACENT TABLES MAY NOT VARY MORE THAN ±1.5% FOR THE DIMENSIONS SHOWN. OTHERWISE THEY MUST CONFORM TO AASHTO M 170.

* WALL "B" THICKNESS

* WALL "B" THICKNESS

LARGE DIAMETER PIPE

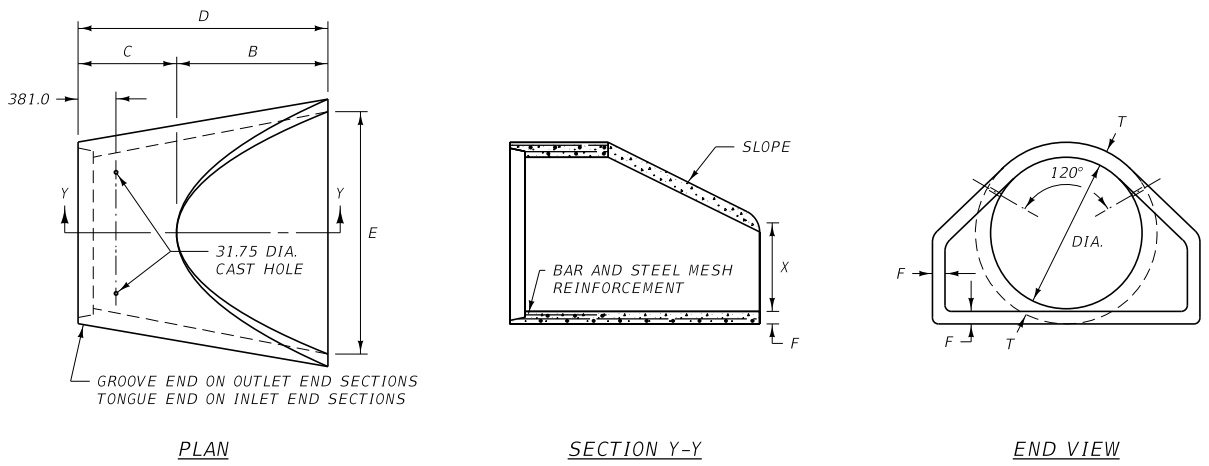

LARGE DIAMETER CULVERT								
DIA.	SLOPE	T *	X	B	C	D	E	F
1500	1.9:1	152.4	889.0	1524.0	990.6	2514.6	2438.4	127.0
1650	1.7:1	165.1	762.0	1828.8	685.8	2514.6	2590.8	139.7
1800	1.9:1	177.8	914.4	1981.2	533.4	2514.6	2743.2	152.4
1950	1.8:1	190.5	914.4	2286.0	533.4	2819.4	2895.6	165.1
2100	1.5:1	203.2	914.4	2298.7	533.4	2832.1	3048.0	165.1
2250	1.5:1	215.9	1041.4	2222.5	609.6	2832.1	3352.8	165.1

* WALL "B" THICKNESS

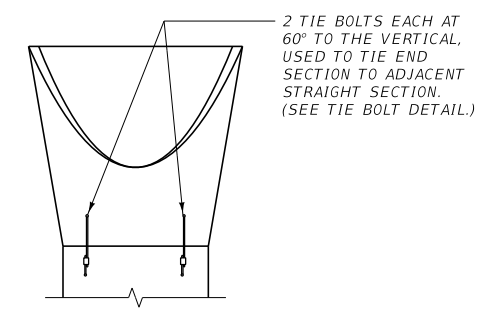

TIE BOLT CONNECTION

TIE BOLTS: USE TWO TIE BOLTS ON ALL FLARED END SECTIONS, ONE ON EACH SIDE AT 60° TO THE VERTICAL. GALVANIZE ALL PARTS. SEE TIE BOLT DETAIL.

CONSTRUCTION: CONSTRUCT PER SECTION 708.

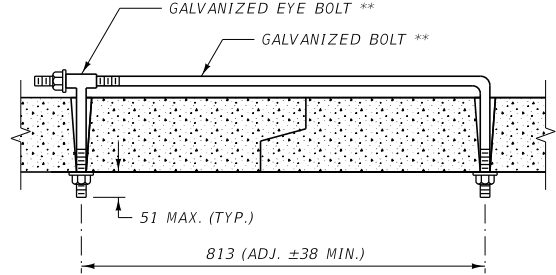

TIE BOLT DETAIL
(TWO PER END SECTION)

** M20 FOR 300 TO 1350 DIA. RCP
M24 FOR 1500 TO 2250 DIA. RCP

ALL DIMENSIONS ARE MILLIMETERS (mm) UNLESS OTHERWISE NOTED.

DETAILED DRAWING	
REFERENCE STANDARD SPEC. SECTION 603.708	DWG. NO. 603-08
PREFABRICATED RCP FLARED END TERMINAL SECTION (FETS) (METRIC)	

DIMENSION TABLE

EQUIV. SIZE	SPAN	RISE	T *	X	B	C	D	E	R	SLOPE
18"	22"	13 1/2"	2 1/2"	7"	27"	45"	72"	36"	3"	3:1
24"	28 1/2"	18"	3 1/2"	8 1/2"	39"	33"	72"	48"	3"	3:1
30"	36 1/4"	22 1/2"	4"	9 1/2"	50"	46"	96"	60"	3"	3:1
36"	43 3/4"	26 5/8"	4 1/2"	11 1/8"	60"	36"	96"	72"	6"	3:1
42"	51 1/8"	31 5/16"	4 1/2"	15 13/16"	60"	36"	96"	78"	6"	3:1
48"	58 1/2"	36"	5"	21"	60"	36"	96"	84"	6"	3:1
54"	65"	40"	5 1/2"	25 1/2"	60"	36"	96"	90"	6"	3:1
60"	73"	45"	6"	31"	60"	36"	96"	96"	6"	3:1
72"	88"	54"	7"	31"	60"	36"	96"	120"	6"	2:1
84"	102"	62"	8"	21 1/2"	84"	24"	108"	144"	6"	2:1

* WALL "B" THICKNESS

METRIC DIMENSION TABLE

EQUIV. SIZE (mm)	SPAN (mm)	RISE (mm)	T* (mm)	X (mm)	B (mm)	C (mm)	D (mm)	E (mm)	R (mm)	SLOPE
450	560	345	63.5	177.8	685.8	1143.0	1828.8	914.4	76.2	3:1
600	725	460	88.9	215.9	990.6	838.2	1828.8	1219.2	76.2	3:1
750	920	570	101.6	241.3	1270.0	1168.4	2438.4	1524.0	76.2	3:1
900	1110	675	114.3	282.6	1524.0	914.4	2438.4	1828.8	152.4	3:1
1050	1300	795	114.3	401.6	1524.0	914.4	2438.4	1981.2	152.4	3:1
1200	1485	915	127.0	533.4	1524.0	914.4	2438.4	2133.6	152.4	3:1
1350	1650	1015	139.7	647.7	1524.0	914.4	2438.4	2286.0	152.4	3:1
1500	1855	1145	152.4	787.4	1524.0	914.4	2438.4	2438.4	152.4	3:1
1800	2235	1370	177.8	787.4	1524.0	914.4	2438.4	3048.0	152.4	2:1
2100	2590	1575	203.2	546.1	2133.6	609.6	2743.2	3657.6	152.4	2:1

* WALL "B" THICKNESS

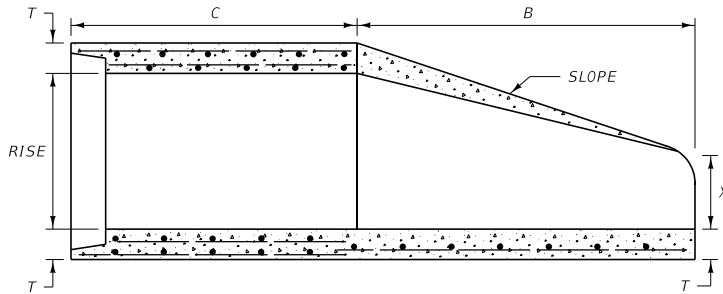

LONGITUDINAL SECTION

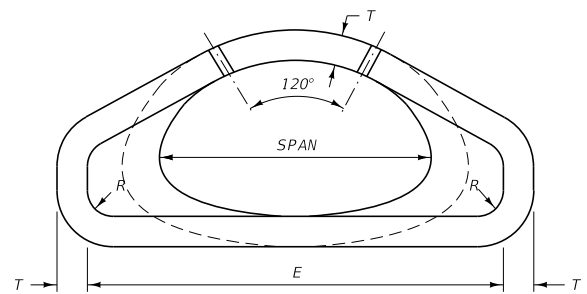

END VIEW

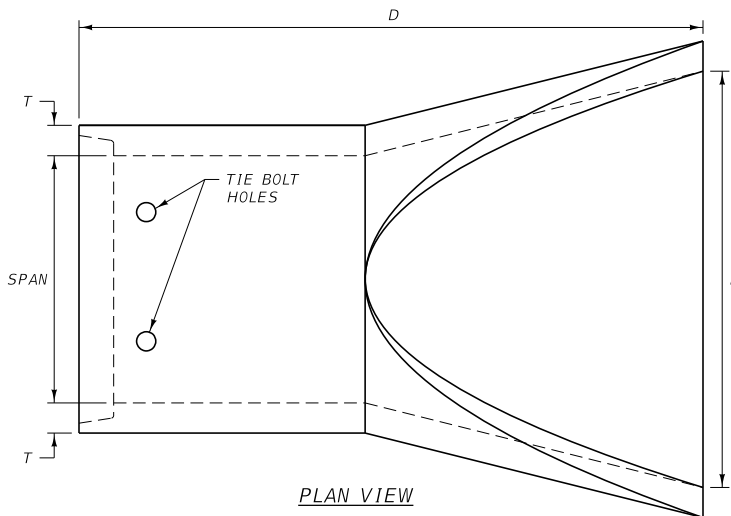

PLAN VIEW

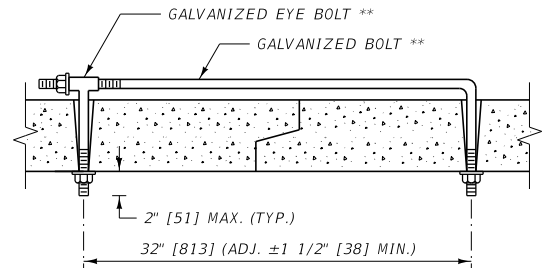

** 3/4" [M20] FOR 18" [450] TO 54" [1350] EQUIV. SIZE 1" [M24] FOR 60" [1500] TO 84" [2100] EQUIV. SIZE

TIE BOLT DETAIL
(TWO PER END SECTION)

TIE BOLTS: USE TIE BOLTS ON ALL FLARED END SECTIONS, ONE ON EACH SIDE AT 60° TO THE VERTICAL. GALVANIZE ALL PARTS PER SECTION 711. SEE TIE BOLT DETAIL.

CONSTRUCTION: CONSTRUCT PER SECTION 708.

UNITS SHOWN IN BRACKETS [] ARE METRIC AND ARE IN MILLIMETERS (mm) UNLESS OTHER UNITS ARE SHOWN.

DETAILED DRAWING	
REFERENCE STANDARD SPEC. SECTION 603, 708, 711	DWG. NO. 603-10
PREFABRICATED RCP ARCH FLARED END TERMINAL SECTION (FETS)	
MONTANA DEPARTMENT OF TRANSPORTATION	

ROAD APPROACH CULVERT END TREATMENT

QUANTITIES (FOR ESTIMATING ONLY)

DIA. A RCP	H PIPE LENGTH	F-64 1/2" x 4 1/8" FERRULE LOOP INSERT (EACH)	LENGTH 2 1/2" DIA. SCHEDULE 40 GALV. PIPE	DIMENSIONS (FT.)						
				B	C	D	E	G	R	J
15"	4.75'	~	~	~	~	0.69	0.27	4.0	0.25	0.75
18"	6.5'	~	~	~	~	0.71	0.25	5.75	0.25	0.75
24"	10.0'	10	12.5'	0.5	2.0	0.75	0.21	9.25	0.25	0.75

METRIC QUANTITIES (FOR ESTIMATING ONLY)

DIA. A RCP	H PIPE LENGTH	M12 x 105 FERRULE LOOP INSERT, EACH	LENGTH 63 DIA. SCHEDULE 40 GALV. PIPE	DIMENSIONS (mm)						
				B	C	D	E	G	R	J
375	1448	~	~	~	~	210	82	1219	76	229
450	1981	~	~	~	~	216	76	1752	76	229
600	3048	10	3800	152	610	229	64	2819	76	229

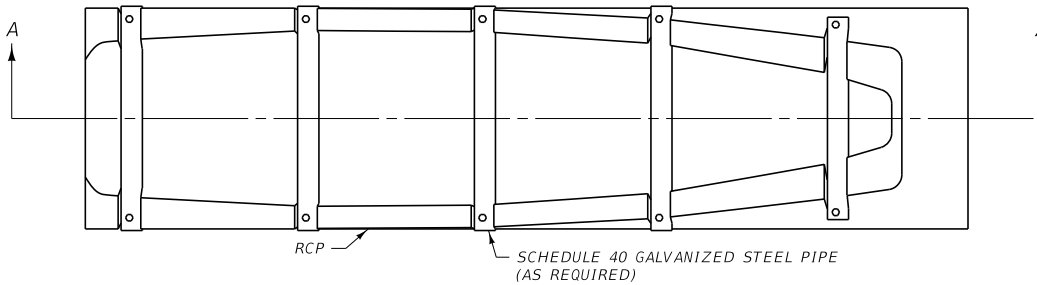

PLAN VIEW

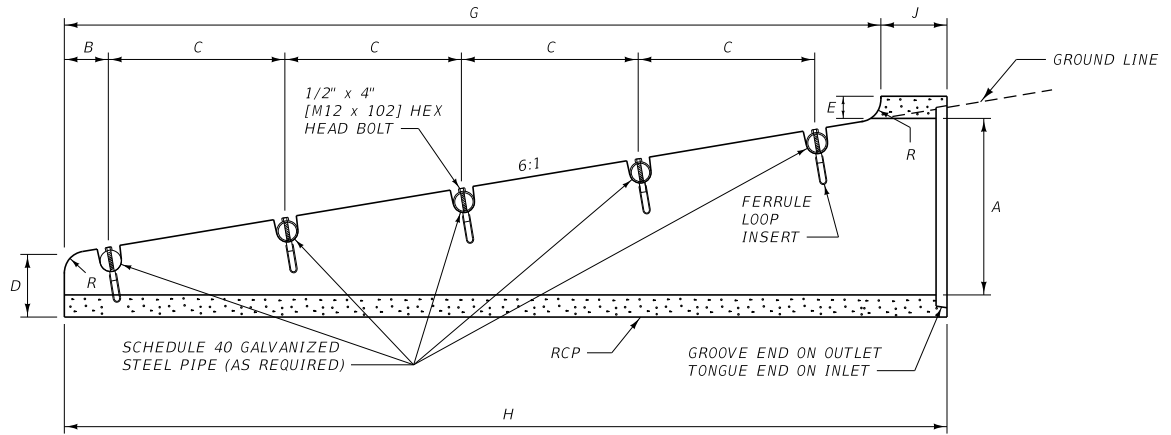

SECTION A-A

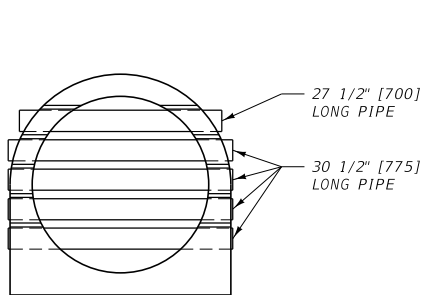

END VIEW

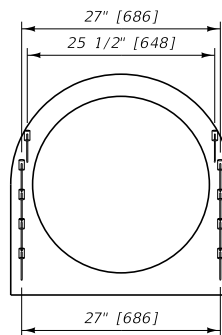

VIEW OF INSERTS

NOTE:
PAINT ALL NON-GALVANIZED PARTS.
PER SECTION 710.

UNITS SHOWN IN BRACKETS [] ARE
METRIC AND ARE IN MILLIMETERS (mm)
UNLESS OTHER UNITS ARE SHOWN.

DETAILED DRAWING

REFERENCE	DWG. NO.
STANDARD SPEC.	603-12
SECTION 603.710.711	

RCP ROAD APPROACH
CULVERT END TREATMENT
(RACET)

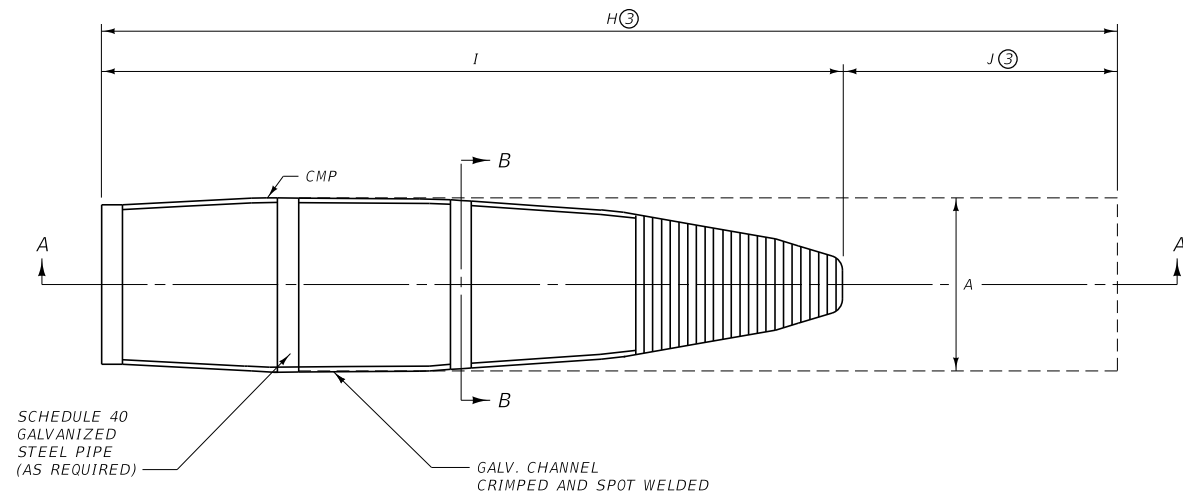

PLAN VIEW

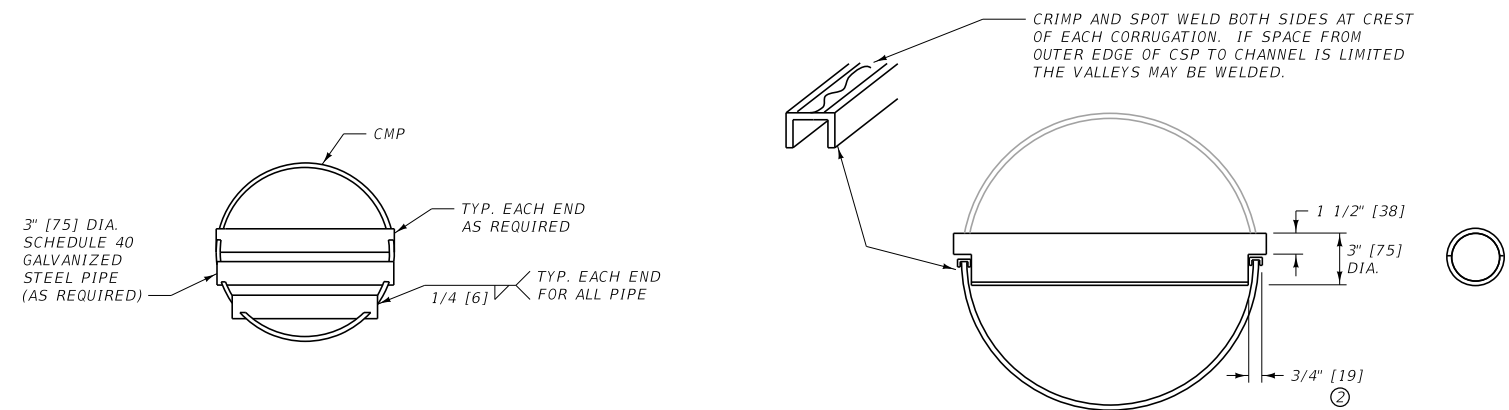

END VIEW

SECTION B-B

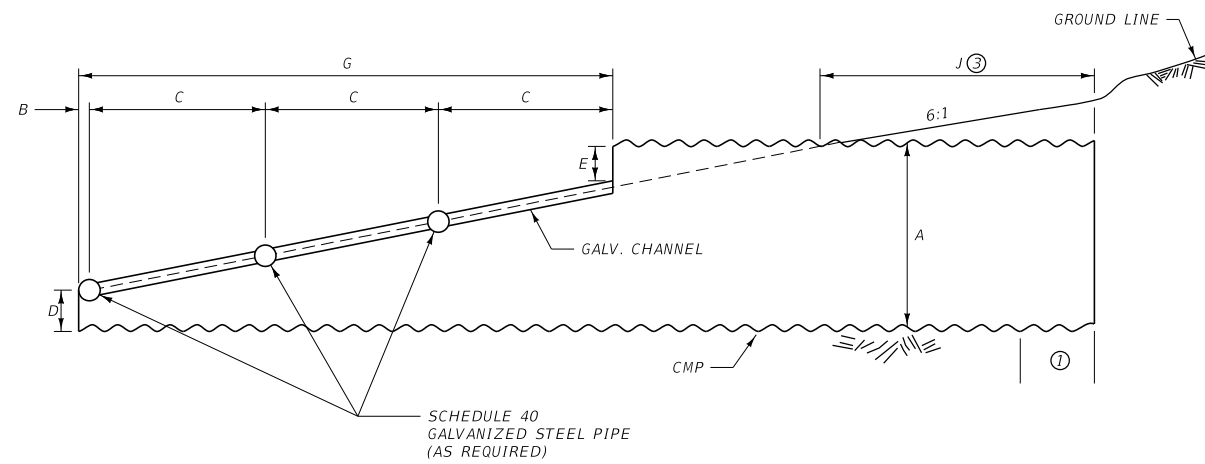

SECTION A-A

ILLUSTRATED WITH 24" [600] CMP (30" [750] CMP UTILIZES FOUR GALV. STEEL PIPES)

NOTES:

- ① PIPE TO HAVE ANNULAR CORRUGATION OR REROLLED ENDS. USE ONLY APPROVED COUPLING BAND PER SECTION 709 FOR CMP. FOR RCP END TREATMENT, SEE DTL. DWG. NO. 603-26 FOR CONNECTION.
- ② THE TWO 3/4" [19] CHANNELS MAY BE ELIMINATED FROM THE CULVERT END TREATMENT IF:
 - A. THE CULVERT IS FABRICATED WITH 12 GAUGE (0.109" [2.8] THICK) MATERIAL.
 - B. HALF CIRCLE NOTCHES ARE CUT IN THE CULVERT FOR THE STEEL PIPE WITH CONTINUOUS WELD OF THE PERIPHERY IN CONTACT PROVIDED.
 - C. ALL WELDS AND OTHER NON-GALVANIZED PARTS ARE PAINTED PER SECTION 710.
- ③ CONNECTIONS MADE PER DTL. DWG. NO. 603-26 REQUIRE PIPE LENGTHS H AND J TO BE INCREASED BY 3" [76].

ROAD APPROACH CULVERT END TREATMENT										
QUANTITIES (FOR ESTIMATING ONLY)										
DIA. A CMP	H PIPE LENGTH	3/4" x 3/8" x 1/8" GALV. CHANNEL	LENGTH 3" DIA SCHEDULE 40 GALV. PIPE	DIMENSIONS (FT.)						
				B	C	D	E	G	I	J
15"	7.0'	10'	~	~	~	0.20	0.20	5.0	6.0	1.0
18"	8.0'	10'	~	~	~	0.33	0.33	5.0	7.0	1.0
24"	10.0'	12'	6.0'	0.15	1.95	0.50	0.50	6.0	9.0	1.0
30"	12.5'	16'	10.0'	0.20	1.95	0.60	0.60	8.0	11.5	1.0
METRIC QUANTITIES (FOR ESTIMATING ONLY) (ALL DIMENSIONS IN MILLIMETERS)										
DIA. A CMP	H PIPE LENGTH	19 x 10 x 3.2 GALV. CHANNEL	LENGTH 75 DIA. SCHEDULE 40 GALV. PIPE	DIMENSIONS						
				B	C	D	E	G	I	J
375	2134	3048	~	~	~	61	61	1524	1829	305
450	2438	3048	~	~	~	101	101	1524	2133	305
600	3048	3656	1800	46	594	152	152	1828	2743	305
750	3810	4874	3000	61	594	183	183	2437	3505	305

UNITS SHOWN IN BRACKETS [] ARE METRIC AND ARE IN MILLIMETERS (mm) UNLESS OTHER UNITS ARE SHOWN.

DETAILED DRAWING	
REFERENCE STANDARD SPEC. SECTION 603.709,710	DWG. NO. 603-14
CMP ROAD APPROACH CULVERT END TREATMENT (RACET)	
MONTANA DEPARTMENT OF TRANSPORTATION	

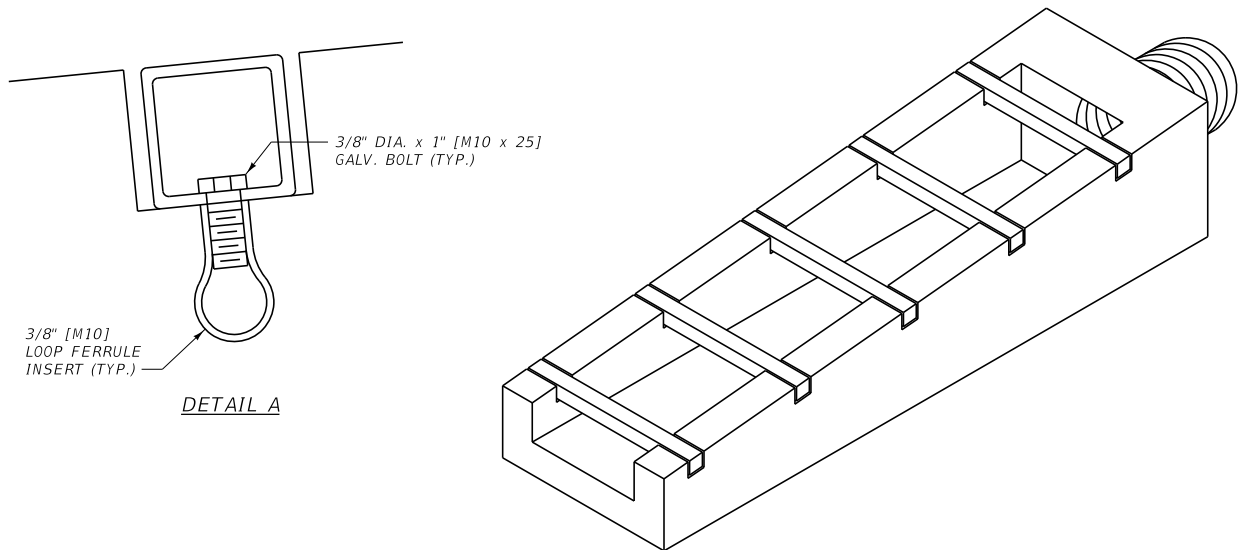
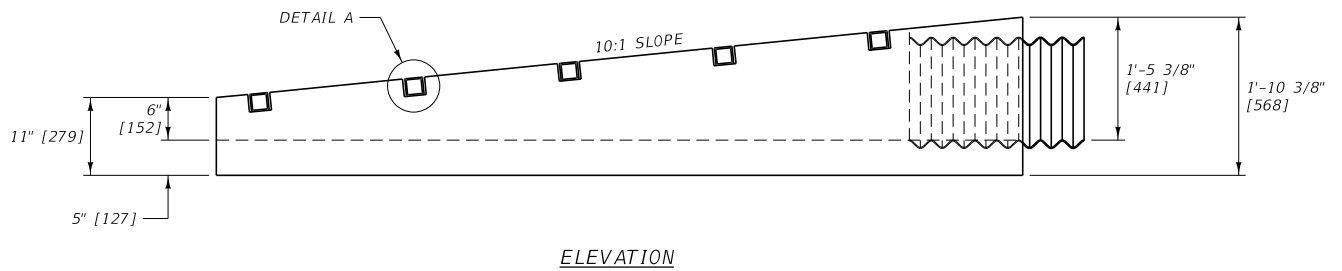
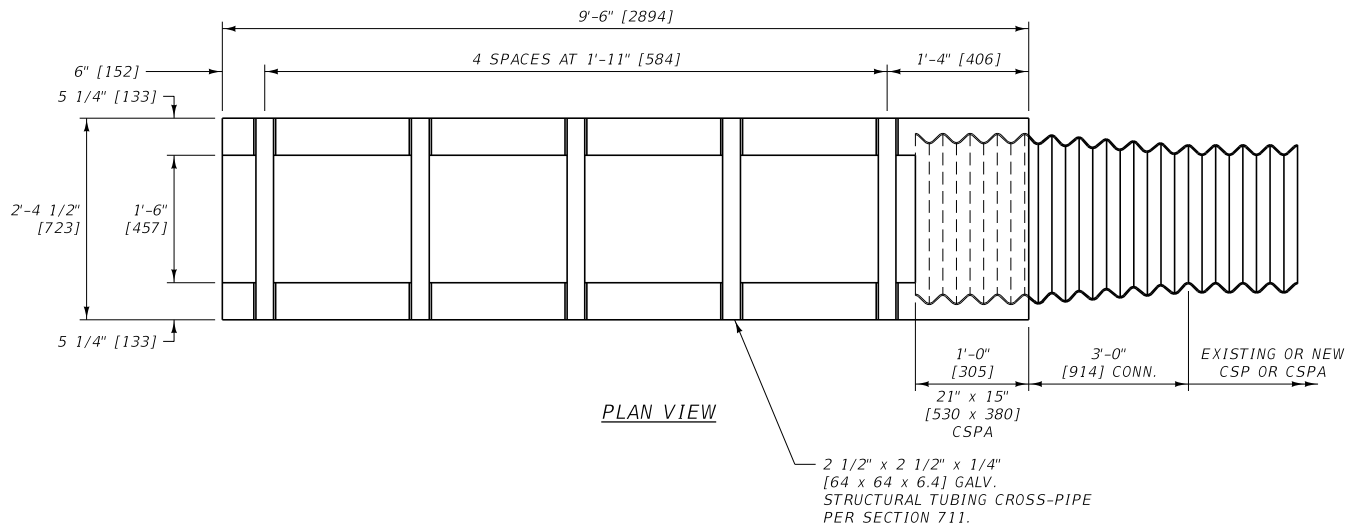

NOTE:
 PAINT ALL EXPOSED METAL PARTS WITH ONE COAT OF ZINC RICH PAINT AND TWO COATS OF ALUMINUM PAINT PER SECTION 710.

UNITS SHOWN IN BRACKETS [] ARE METRIC AND ARE IN MILLIMETERS (mm) UNLESS OTHER UNITS ARE SHOWN.

DETAILED DRAWING	
REFERENCE STANDARD SPEC. SECTION 603,708,710,711	DWG. NO. 603-17
PRECAST MEDIAN U-TURN CROSS DRAIN AND CONC. BEVELED END	
 MONTANA DEPARTMENT OF TRANSPORTATION	

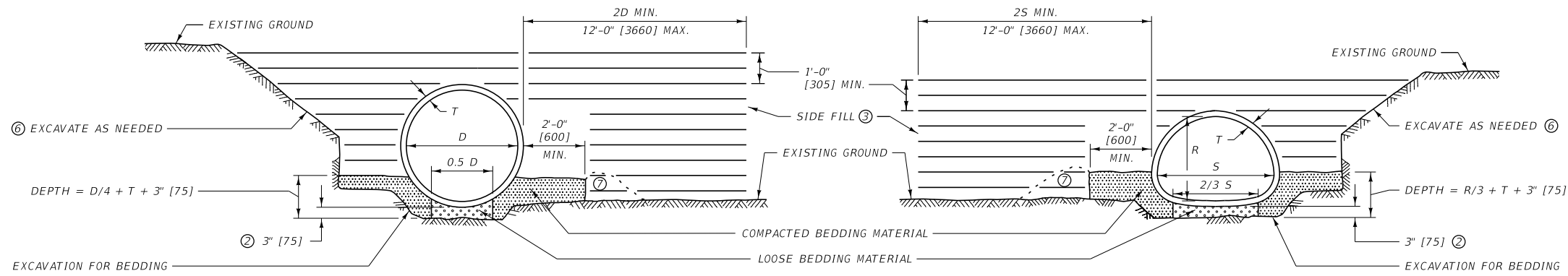

1-STANDARD BEDDING INSTALLATION

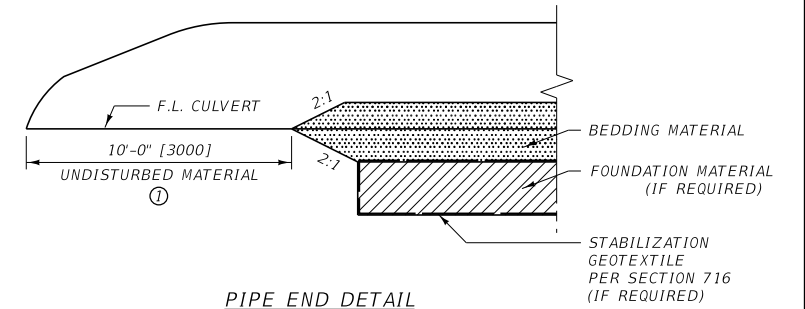

PIPE END DETAIL

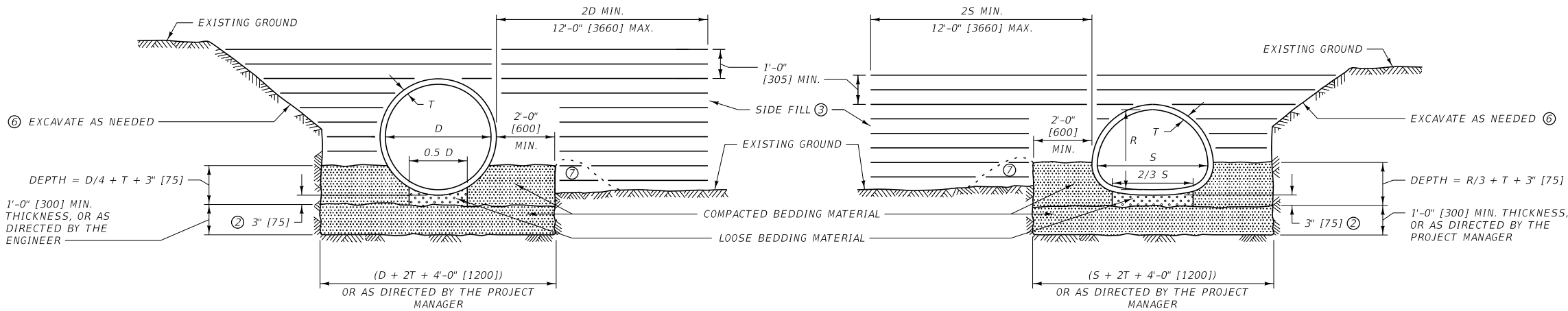

2-ROCK

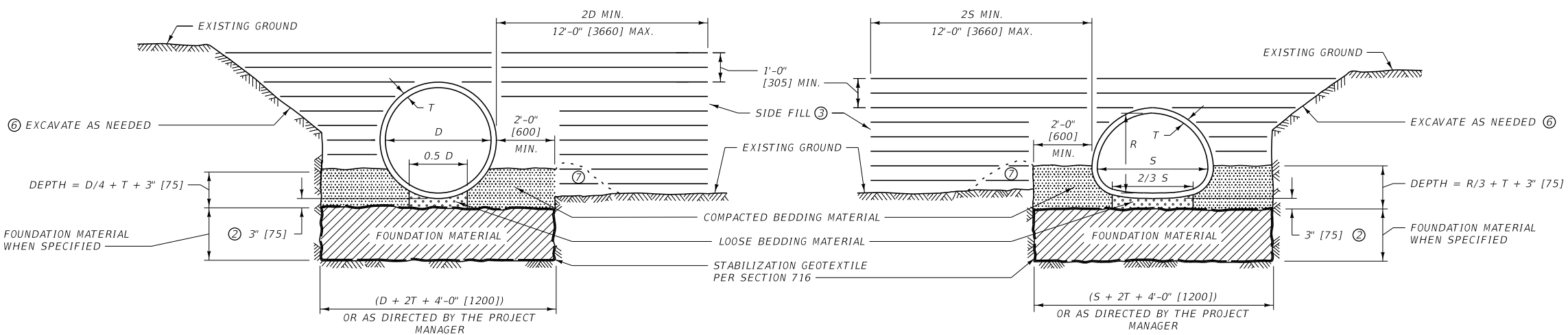

3-FOUNDATION STABILIZATION

NOTES:

- ① DO NOT EXTEND BEDDING MATERIAL TO THE END OF THE PIPE. LEAVE 10' [3000] OF UNDISTURBED MATERIAL AT EACH END UNLESS OTHERWISE NOTED IN PLANS. SEE PIPE END DETAIL.
- ② PLACE LOOSE BEDDING MATERIAL UNIFORMLY IN THE BOTTOM OF THE TRENCH AND SHAPE TO FIT BOTTOM OF PIPE. THE MINIMUM THICKNESS BEFORE PLACING PIPE 15 3" [75], 42" [1050] AND 48" [1200] RCP IRR. REQUIRE 4" [100] DEPTH OF LOOSE BEDDING MATERIAL TO ACCOMMODATE BELL THICKNESS. AFTER LAYING CULVERT, COMPACT BEDDING MATERIAL AT HAUNCHES AND SIDES OF PIPE.
- ③ COMPACT AND PLACE SIDE FILL PER SECTION 603 AND 203.
- ④ FURNISH BEDDING AND FOUNDATION MATERIAL PER SECTION 701.
- ⑤ DIMENSIONS D, S AND R ARE INSIDE PIPE DIAMETER, SPAN AND RISE. DIMENSION T IS THE CULVERT WALL THICKNESS FOR CONCRETE OR CORRUGATION DEPTH FOR METAL. CORRUGATION WIDTHS ARE TYPICALLY 1/2" [13] FOR 48" [1200] EQUIVALENT SIZE METAL CULVERTS AND SMALLER.
- ⑥ EXCAVATE A SUFFICIENT AMOUNT TO PROVIDE A SAFE WORKING ENVIRONMENT AND TO ALLOW ACHIEVEMENT OF ALL CULVERT INSTALLATION AND COMPACTION REQUIREMENTS. SLOPE, BENCH OR PROVIDE SHORING FOR ALL EXCAVATIONS IN ACCORDANCE WITH THE U.S. DEPARTMENT OF LABOR, OCCUPATIONAL SAFETY AND HEALTH ADMINISTRATION (OSHA) SAFETY AND HEALTH REGULATIONS FOR CONSTRUCTION.
- ⑦ BUILD BERM WITH FILL MATERIAL AS NEEDED TO CONTAIN THE BEDDING MATERIAL TO THE PROPER DEPTH.

UNITS SHOWN IN BRACKETS [] ARE METRIC AND ARE IN MILLIMETERS (mm) UNLESS OTHER UNITS ARE SHOWN.

DETAILED DRAWING	
REFERENCE STANDARD SPEC. SECTION 203.207.603,701	DWG. NO. 603-18

BEDDING FOR PIPES LESS THAN 54" [1350 mm] IN DIAMETER

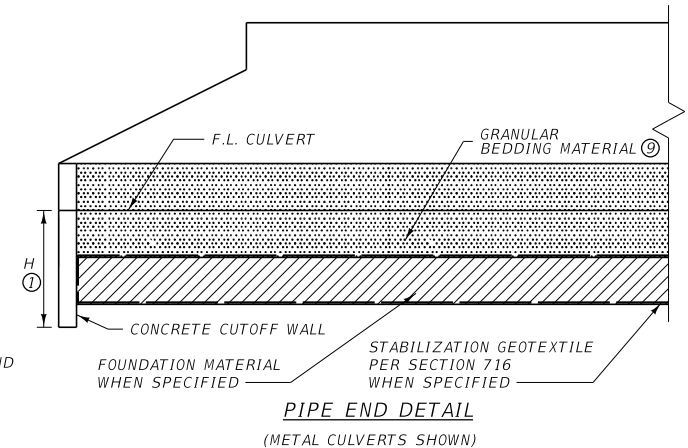
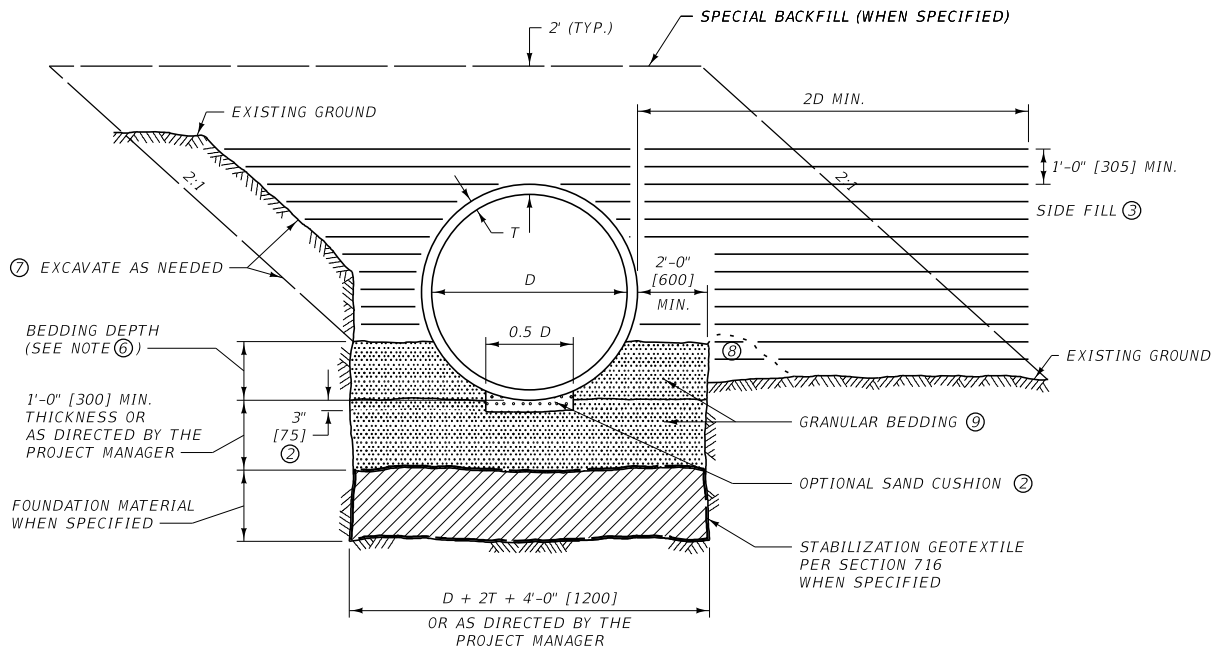

NOTES:

- ① 3'-0" [900] MIN. OR 1'-0" [300] BELOW BOTTOM OF FOUNDATION MATERIAL IF SPECIFIED.
- ② THE CONTRACTOR HAS THE OPTION OF USING A SAND CUSHION AS APPROVED BY THE PROJECT MANAGER TO FACILITATE CULVERT INSTALLATION. IF A SAND CUSHION IS USED, THAT MATERIAL WILL BE MEASURED AND PAID FOR AS GRANULAR BEDDING.
- ③ COMPACT AND PLACE SIDE FILL PER SECTION 603 AND 203.
- ④ FURNISH GRANULAR BEDDING AND FOUNDATION MATERIAL PER SECTION 701.
- ⑤ DIMENSIONS D, S, AND R ARE THE INSIDE PIPE DIAMETER, SPAN, AND RISE. DIMENSION T IS THE CULVERT SHELL THICKNESS FOR CONCRETE OR CORRUGATION DEPTH FOR METAL.
- ⑥ THE BEDDING DEPTH FOR CONCRETE PIPE IS $D/4 + T$ OR $R/3 + T$. THE BEDDING DEPTH FOR METAL PIPE IS "X" + T. SEE DTL. DWG. NO. 603-32 AND 603-34 FOR "X" DIMENSIONS OF METAL PIPES. AFTER LAYING CULVERT, COMPACT GRANULAR BEDDING AT HAUNCHES AND SIDES.
- ⑦ EXCAVATE A SUFFICIENT AMOUNT TO PROVIDE A SAFE WORKING ENVIRONMENT AND TO ALLOW ACHIEVEMENT OF ALL CULVERT INSTALLATION AND COMPACTION REQUIREMENTS. SLOPE, BENCH OR PROVIDE SHORING FOR ALL EXCAVATIONS IN ACCORDANCE WITH THE U.S. DEPARTMENT OF LABOR, OCCUPATIONAL SAFETY AND HEALTH ADMINISTRATION (OSHA) SAFETY AND HEALTH REGULATIONS FOR CONSTRUCTION.
- ⑧ BUILD BERM WITH FILL MATERIAL AS NEEDED TO CONTAIN THE GRANULAR BEDDING MATERIAL TO THE PROPER DEPTH.
- ⑨ COMPACT GRANULAR BEDDING BY PROOF ROLLING WITH A VIBRATORY COMPACTOR IN 12 INCH LIFTS OR BY USING A METHOD APPROVED BY THE PROJECT MANAGER.

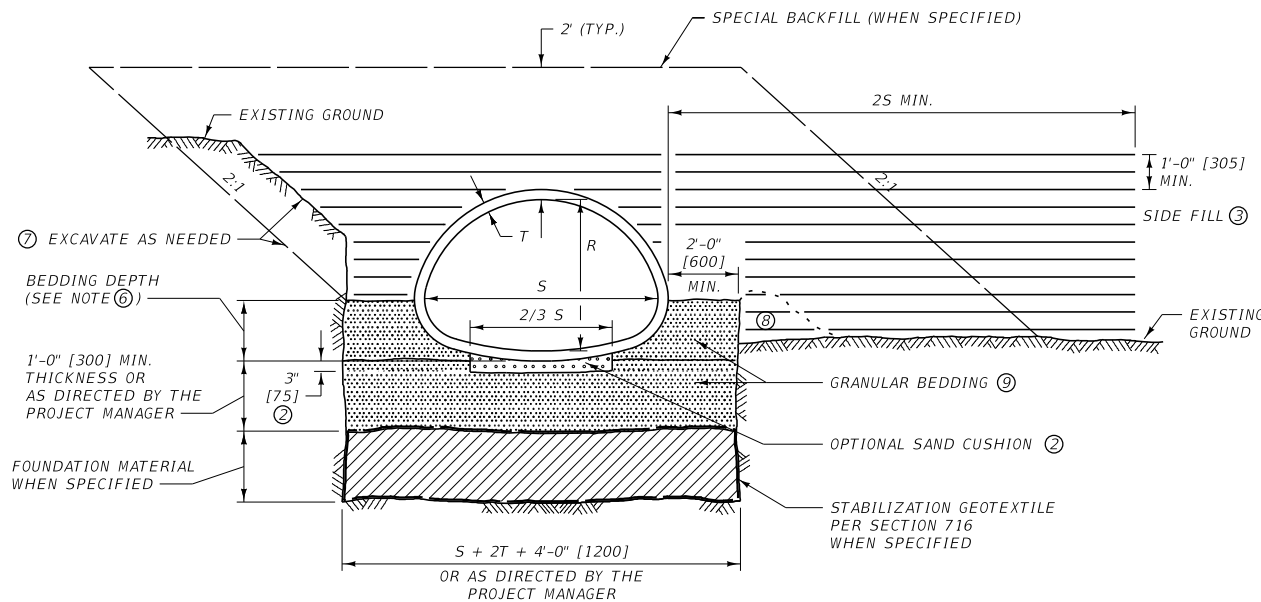

UNITS SHOWN IN BRACKETS [] ARE METRIC AND ARE IN MILLIMETERS (mm) UNLESS OTHER UNITS ARE SHOWN.

DETAILED DRAWING	
REFERENCE	DWG. NO.
STANDARD SPEC.	603-19
SECTION 203,207,603,701	
GRANULAR BEDDING FOR CULVERTS 54" [1350 mm] EQUIVALENT & LARGER	
 MONTANA DEPARTMENT OF TRANSPORTATION	

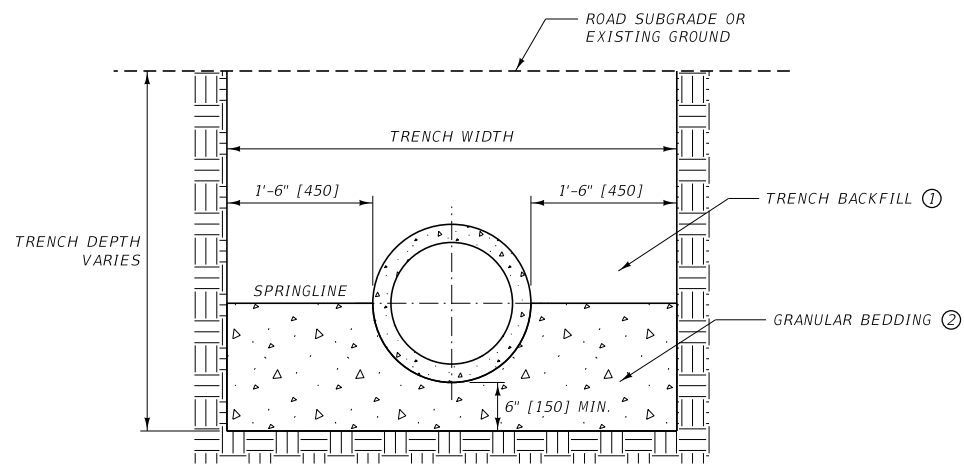

**RIGID PIPE
TRENCH/BEDDING DETAIL
FOR 12" [300] TO 54" [1350] DIA.**

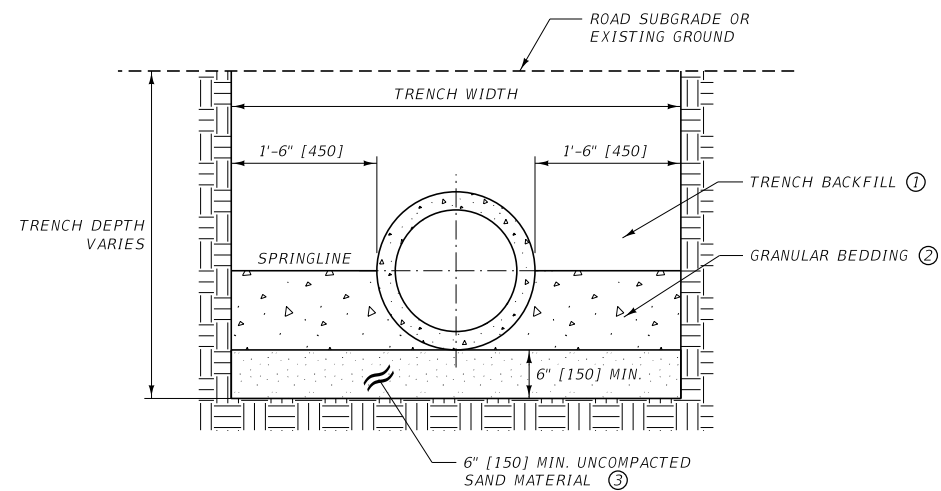

**RIGID PIPE
TRENCH/BEDDING DETAIL
FOR 60" [1500] TO 84" [2100] DIA.**

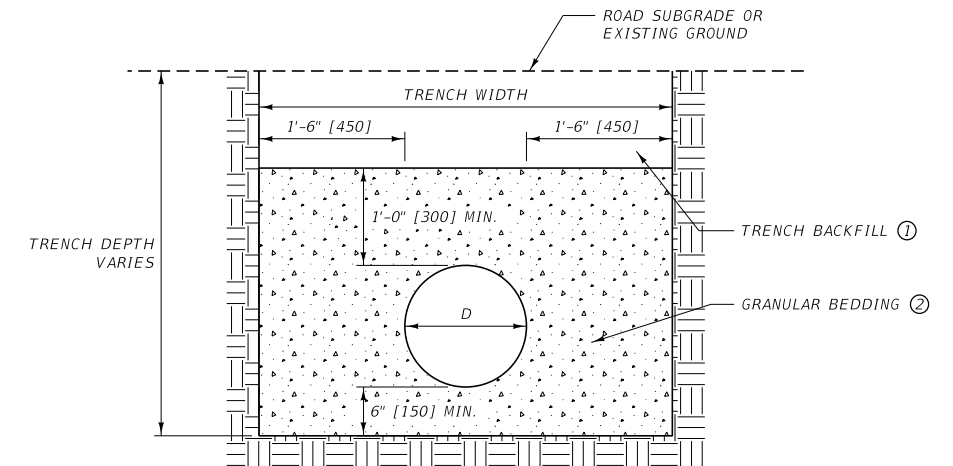

**FLEXIBLE PIPE
TRENCH/BEDDING DETAIL
FOR 12" [300] TO 48" [1200] DIA.**

QUANTITIES*		METRIC QUANTITIES	
RIGID PIPE 12" TO 54" DIA.		RIGID PIPE 300 TO 1350 DIA.	
DIAMETER	GRANULAR BEDDING (C.Y. PER Ft.)	DIAMETER (mm)	GRANULAR BEDDING (m ³ PER m)
12"	0.15	300	0.39
18"	0.20	450	0.50
24"	0.25	600	0.63
30"	0.30	750	0.75
36"	0.35	900	0.88
42"	0.41	1050	1.02
48"	0.46	1200	1.16
54"	0.52	1350	1.30

* BASED ON RCP B WALL PIPE.

QUANTITIES*		METRIC QUANTITIES	
RIGID PIPE 60" TO 84" DIA.		RIGID PIPE 1500 TO 2100 DIA.	
DIAMETER	GRANULAR BEDDING (C.Y. PER Ft.)	DIAMETER (mm)	GRANULAR BEDDING (m ³ PER m)
60"	0.48	1500	1.19
66"	0.54	1650	1.35
72"	0.60	1800	1.51
78"	0.67	1950	1.68
84"	0.74	2100	1.85

* BASED ON RCP B WALL PIPE.

QUANTITIES*		METRIC QUANTITIES	
FLEXIBLE PIPE 12" TO 48" DIA.		FLEXIBLE PIPE 300 TO 1200 DIA.	
DIAMETER	GRANULAR BEDDING (C.Y. PER Ft.)	DIAMETER (mm)	GRANULAR BEDDING (m ³ PER m)
12"	0.37	300	0.93
18"	0.47	450	1.17
24"	0.57	600	1.42
30"	0.67	750	1.67
36"	0.77	900	1.94
42"	0.88	1050	2.22
48"	1.00	1200	2.51

* BASED ON 1" [25 mm] NOMINAL WALL THICKNESS.

NOTES

① TRENCH BACKFILL: PLACE PER STANDARD SPECIFICATION 603.03.4. GRANULAR BEDDING MAY BE SUBSTITUTED AT NO ADDITIONAL COST.

② THE BEDDING MATERIAL DIRECTLY UNDERNEATH THE PIPE SHOULD BE LEFT UNCOMPACTED TO FACILITATE THE INSTALLATION OF THE PIPE.

COMPACT GRANULAR BEDDING BY PROOF ROLLING WITH VIBRATORY COMPACTOR IN 8 INCH [200] LIFTS OR BY USING A METHOD APPROVED BY THE PROJECT MANAGER.

INCLUDE THE COST OF GRANULAR BEDDING MATERIAL FOR PIPES LESS THAN 54" [1350 mm] DIAMETER IN THE COST OF PIPE.

③ SAND CUSHION: USE GRADE 5 MATERIAL PER TABLE 701-7 IN STANDARD SPECIFICATION 701.02.3.

THE SAND MATERIAL SHOULD BE LEFT UNCOMPACTED TO FACILITATE THE INSTALLATION OF THE PIPE.

UNITS SHOWN IN BRACKETS [] ARE METRIC AND ARE IN MILLIMETERS (mm) UNLESS OTHER UNITS ARE SHOWN.

DETAILED DRAWING	
REFERENCE STANDARD SPEC. SECTION 603.701	DWG. NO. 603-20

STORM DRAIN
TRENCH BEDDING DETAIL

DIMENSION TABLE

DIA. D	APPROX. DIA. GASKET MATL. NOT STRETCHED	LENGTH OF JOINT J	D1	D2	L2 (MIN.)	L1 (WALL" B")	L1 (WALL" C")	X1	X2	Y1	Y2	Y3
12"	21/32"	3 5/8"	15.223"	15.331"	5"	2"	~	1"	7/8"	0.062"	0.090"	0.313"
15"	21/32"	3 5/8"	18.723"	18.831"	4 3/4"	2 3/16"	~	1"	7/8"	0.062"	0.090"	0.313"
18"	21/32"	3 5/8"	22.098"	22.206"	5"	2 3/8"	~	1"	7/8"	0.062"	0.090"	0.313"
21"	21/32"	3 7/8"	25.600"	25.724"	5 1/4"	2 9/16"	~	1"	7/8"	0.062"	0.090"	0.313"
24"	21/32"	3 7/8"	28.975"	29.099"	5 1/2"	2 3/4"	2"	1"	7/8"	0.062"	0.090"	0.313"
27"	21/32"	4"	32.476"	32.608"	5 1/2"	2 3/4"	2"	1"	7/8"	0.062"	0.090"	0.313"
30"	21/32"	4"	35.976"	36.108"	5 1/2"	2 3/4"	2"	1"	7/8"	0.062"	0.090"	0.313"
33"	21/32"	4 1/8"	39.476"	39.616"	5 3/4"	2 7/8"	2 1/8"	1"	7/8"	0.062"	0.090"	0.313"
36"	21/32"	4 1/8"	42.976"	43.116"	6"	3 1/8"	2 3/8"	1"	7/8"	0.062"	0.090"	0.313"
42"	3/4"	4 5/8"	50.183"	50.183"	6 3/4"	3 3/4"	3"	1 3/16"	1"	0.067"	0.129"	0.376"
48"	3/4"	4 3/4"	57.023"	57.193"	7 1/4"	4 1/8"	3 3/8"	1 3/16"	1"	0.067"	0.129"	0.376"
54"	3/4"	5"	63.007"	63.192"	7 1/2"	3 5/8"	2 7/8"	1 3/16"	1"	0.067"	0.129"	0.376"
60"	3/4"	5"	69.007"	69.192"	7 1/2"	3 1/8"	2 3/8"	1 3/16"	1"	0.067"	0.129"	0.376"
66"	13/16"	5"	75.007"	75.192"	7 1/2"	2 3/4"	2"	1 3/16"	1"	0.067"	0.129"	0.376"
72"	13/16"	5 1/4"	79.250"	79.400"	~	~	~	1 3/16"	1 1/4"	0.093"	0.190"	0.376"
78"	13/16"	5 1/4"	86.250"	86.400"	~	~	~	1 3/16"	1 1/4"	0.093"	0.190"	0.376"
84"	13/16"	5 1/4"	91.500"	91.650"	~	~	~	1 3/16"	1 1/4"	0.093"	0.190"	0.376"
90"	13/16"	5 1/4"	97.750"	97.900"	~	~	~	1 3/16"	1 1/4"	0.093"	0.190"	0.376"
96"	13/16"	5 1/4"	104.250"	104.400"	~	~	~	1 3/16"	1 1/4"	0.093"	0.190"	0.376"
102"	13/16"	5 1/4"	110.750"	110.900"	~	~	~	1 3/16"	1 1/4"	0.093"	0.190"	0.376"
108"	13/16"	5 1/4"	117.250"	117.400"	~	~	~	1 3/16"	1 1/4"	0.093"	0.190"	0.376"

METRIC DIMENSION TABLE (mm)

DIA. D	APPROX. DIA. GASKET MATL. NOT STRETCHED	LENGTH OF JOINT J	D1	D2	L2 (MIN.)	L1 (WALL" B")	L1 (WALL" C")	X1	X2	Y1	Y2	Y3
300	16.67	92.08	386.66	389.41	127.00	50.80	~	25.40	22.23	1.57	2.29	7.95
375	16.67	92.08	475.56	478.31	120.65	55.56	~	25.40	22.23	1.57	2.29	7.95
450	16.67	92.08	561.29	564.03	127.00	60.33	~	25.40	22.23	1.57	2.29	7.95
525	16.67	98.43	650.24	653.39	133.35	65.09	~	25.40	22.23	1.57	2.29	7.95
600	16.67	98.43	735.97	739.11	139.70	69.85	50.80	25.40	22.23	1.57	2.29	7.95
675	16.67	101.60	824.89	828.24	139.70	69.85	50.80	25.40	22.23	1.57	2.29	7.95
750	16.67	101.60	913.79	917.14	139.70	69.85	50.80	25.40	22.23	1.57	2.29	7.95
825	16.67	104.78	1002.69	1006.25	146.05	73.03	53.98	25.40	22.23	1.57	2.29	7.95
900	16.67	104.78	1091.59	1095.15	152.40	79.38	60.33	25.40	22.23	1.57	2.29	7.95
1050	19.05	117.48	1274.65	1274.65	171.45	95.25	76.20	30.16	25.40	1.70	3.28	9.55
1200	19.05	120.65	1448.38	1452.70	184.15	104.78	85.73	30.16	25.40	1.70	3.28	9.55
1350	19.05	127.00	1600.38	1605.08	190.50	92.08	73.03	30.16	25.40	1.70	3.28	9.55
1500	19.05	127.00	1752.78	1757.48	190.50	79.38	60.33	30.16	25.40	1.70	3.28	9.55
1650	20.64	127.00	1905.18	1909.88	190.50	69.85	50.80	30.16	25.40	1.70	3.28	9.55
1800	20.64	133.35	2012.95	2016.76	~	~	~	30.16	31.75	2.36	4.83	9.55
1950	20.64	133.35	2190.75	2194.56	~	~	~	30.16	31.75	2.36	4.83	9.55
2100	20.64	133.35	2324.10	2327.91	~	~	~	30.16	31.75	2.36	4.83	9.55
2250	20.64	133.35	2482.85	2486.66	~	~	~	30.16	31.75	2.36	4.83	9.55
2400	20.64	133.35	2647.95	2651.76	~	~	~	30.16	31.75	2.36	4.83	9.55
2550	20.64	133.35	2813.05	2816.86	~	~	~	30.16	31.75	2.36	4.83	9.55
2700	20.64	133.35	2978.15	2981.96	~	~	~	30.16	31.75	2.36	4.83	9.55

72" [1800] DIA. PIPES AND LARGER

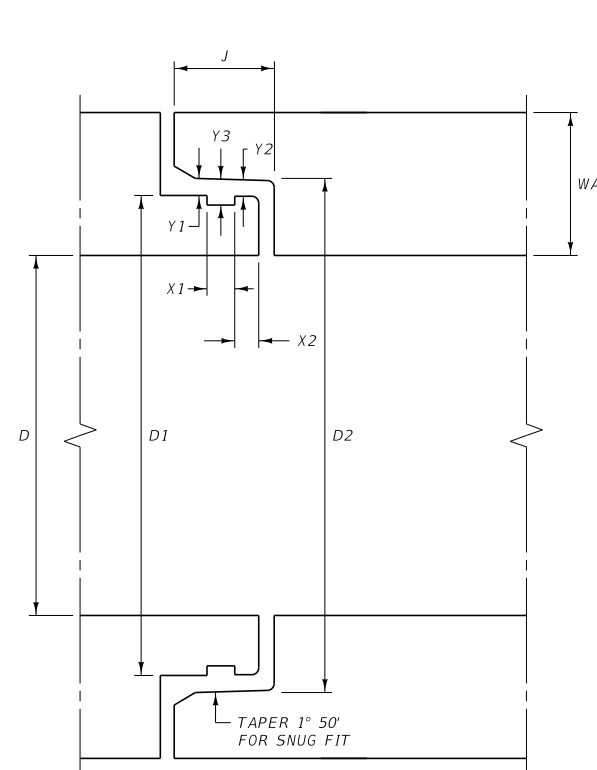

66" [1650] DIA. PIPES AND SMALLER

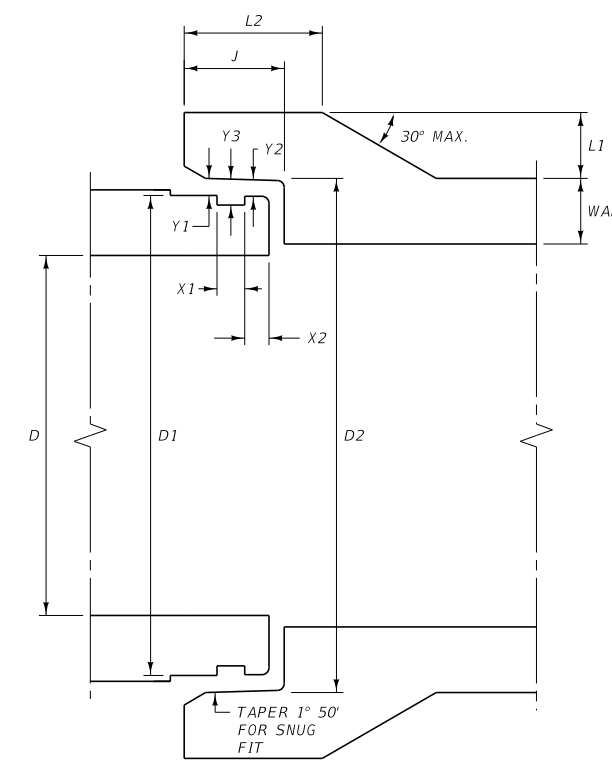

NOTES:

TYPICAL FOR STORM DRAIN AND IRRIGATION APPLICATIONS (FOR HEADS UP TO 20 FEET [6.1 m]).

USE RUBBER GASKETS THAT MEET THE REQUIREMENTS OF SECTION 707.

UNITS SHOWN IN BRACKETS [] ARE METRIC AND ARE IN MILLIMETERS (mm) UNLESS OTHER UNITS ARE SHOWN.

DETAILED DRAWING
REFERENCE DWG. NO.
STANDARD SPEC. 603-22
SECTION 603.707.708

WATER TIGHT JOINT FOR REINFORCED CONCRETE PIPE

DIMENSION TABLE

DIA. D	XSEC. WATER AREA (SQ. FT.)	WT. PER FOOT OF PIPE (LB.)	T * MIN. WALL THICKNESS	J LENGTH OF JOINT	A (NOMINAL) = $\frac{D2 - D1}{2}$	D1	D2	D3	D4
12"	0.79	92	2"	1 3/4"	3/16"	13 1/4"	13 5/8"	13 7/8"	14 1/4"
15"	1.23	127	2 1/4"	2"	3/16"	16 1/2"	16 7/8"	17 1/4"	17 5/8"
18"	1.77	168	2 1/2"	2 1/4"	3/16"	19 5/8"	20"	20 3/8"	20 3/4"
21"	2.40	214	2 3/4"	2 1/2"	3/16"	22 7/8"	23 1/4"	23 3/4"	24 1/8"
24"	3.14	265	3"	2 3/4"	3/16"	26"	26 3/8"	27"	27 3/8"
27"	3.98	322	3 1/4"	3"	3/16"	29 1/4"	29 5/8"	30 1/4"	30 5/8"
30"	4.91	384	3 1/2"	3 1/4"	3/16"	32 3/8"	32 3/4"	33 1/2"	33 7/8"
33"	5.94	452	3 3/4"	3 1/2"	1/4"	35 1/2"	36"	36 3/4"	37 1/4"
36"	7.07	524	4"	3 3/4"	1/4"	38 3/4"	39 1/4"	40"	40 1/2"
42"	9.62	685	4 1/2"	4"	1/4"	45 1/8"	45 3/8"	46 1/2"	47"
48"	12.57	867	5"	4 1/4"	1/4"	51 1/2"	52"	53"	53 1/2"
54"	15.90	1070	5 1/2"	4 1/2"	1/4"	57 7/8"	58 3/8"	59 3/8"	59 7/8"
60"	19.63	1296	6"	5"	1/4"	64 1/4"	64 3/4"	66"	66 1/2"
66"	23.76	1542	6 1/2"	5 1/2"	1/4"	70 5/8"	71 1/8"	72 1/2"	73"
72"	28.27	1810	7"	6"	1/4"	77"	77 1/2"	79"	79 1/2"
78"	33.18	2098	7 1/2"	6 1/2"	1/4"	83 3/8"	83 7/8"	85 5/8"	86 1/3"
84"	38.48	2410	8"	7"	1/4"	89 3/4"	90 1/4"	92 1/8"	92 5/8"
90"	44.18	2740	8 1/2"	7"	1/4"	95 3/4"	96 1/4"	98 1/8"	98 5/8"
96"	50.27	2950	9"	7"	1/4"	102 1/8"	102 5/8"	104 1/2"	105"
102"	56.75	3075	9 1/2"	7 1/2"	1/4"	109"	109 1/2"	111 1/2"	112"
108"	63.62	3870	10"	7 1/2"	1/4"	115 1/2"	116"	118"	118 1/2"

* WALL "B" THICKNESS

METRIC DIMENSION TABLE

DIA. D	XSEC. WATER AREA (m ²)	WT. PER m OF PIPE (kg)	T * MIN. WALL THICKNESS	J LENGTH OF JOINT	A (NOMINAL) = $\frac{D2 - D1}{2}$	D1	D2	D3	D4
300	0.073	136.9	50.8	44.45	4.76	336.55	346.08	352.43	361.95
375	0.114	189.0	57.2	50.80	4.76	419.10	428.63	438.15	447.68
450	0.164	250.0	63.5	57.15	4.76	498.48	508.00	517.53	527.05
525	0.223	318.5	69.9	63.50	4.76	581.03	590.55	603.25	612.78
600	0.292	394.4	76.2	69.85	4.76	660.40	669.93	685.80	695.33
675	0.369	479.2	82.6	76.20	4.76	742.95	752.48	768.35	777.88
750	0.456	571.5	88.9	82.55	4.76	822.33	831.85	850.90	860.43
825	0.552	672.6	95.3	88.90	6.35	901.70	914.40	933.45	946.15
900	0.657	779.8	101.6	95.25	6.35	984.25	996.95	1016.00	1028.70
1050	0.894	1019.4	114.3	101.60	6.35	1146.18	1152.53	1181.10	1193.80
1200	1.167	1290.2	127.0	107.95	6.35	1308.10	1320.80	1346.20	1358.90
1350	1.478	1592.3	139.7	114.30	6.35	1470.03	1482.73	1508.13	1520.83
1500	1.824	1928.7	152.4	127.00	6.35	1631.95	1644.65	1676.40	1689.10
1650	2.207	2294.7	165.1	139.70	6.35	1793.88	1806.58	1841.50	1854.20
1800	2.627	2693.6	177.8	152.40	6.35	1955.80	1968.50	2006.60	2019.30
1950	3.083	3122.2	190.5	165.10	6.35	2117.73	2130.43	2174.88	2192.87
2100	3.575	3586.5	203.2	177.80	6.35	2279.65	2292.35	2339.98	2352.68
2250	4.104	4077.6	215.9	177.80	6.35	2432.05	2444.75	2492.38	2505.08
2400	4.670	4390.1	228.6	177.80	6.35	2593.98	2606.68	2654.30	2667.00
2550	5.272	4576.1	241.3	190.50	6.35	2768.60	2781.30	2832.10	2844.80
2700	5.910	5759.2	254.0	190.50	6.35	2933.70	2946.40	2997.20	3009.90

NOTE: ALL DIMENSIONS ARE IN MILLIMETERS UNLESS OTHERWISE NOTED

* WALL "B" THICKNESS

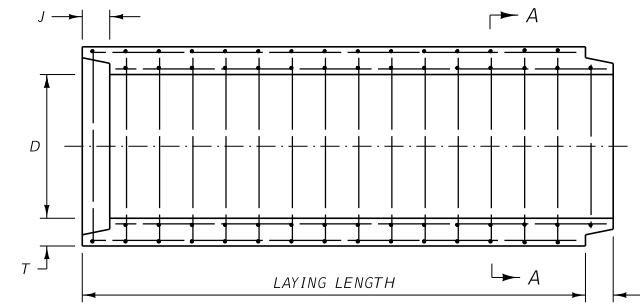

TYPICAL LONGITUDINAL SECTION

36" [900] DIAMETER PIPES AND LARGER

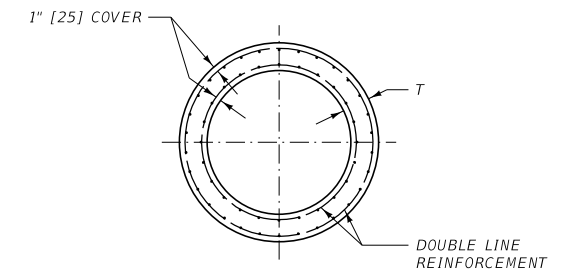

SECTION A-A

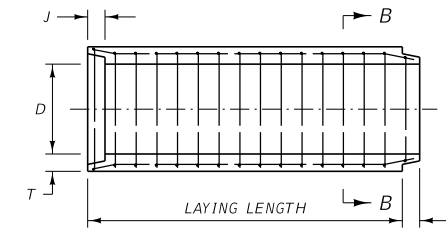

TYPICAL LONGITUDINAL SECTION

33" [825] DIAMETER PIPES AND SMALLER

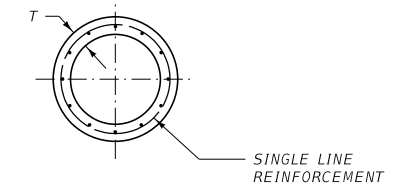

SECTION B-B

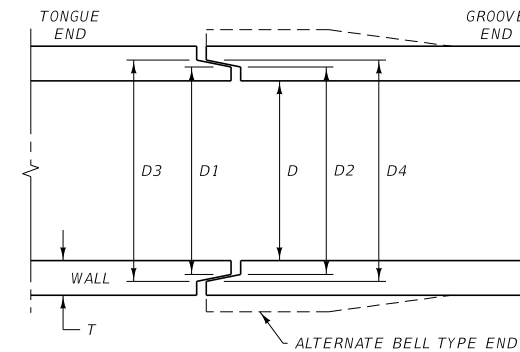

JOINT DETAIL

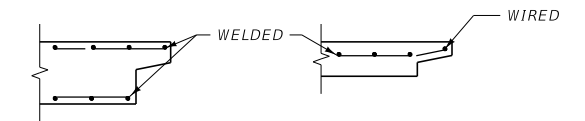

REINFORCING AT ENDS OF PIPE

NOTES:

PROVIDE TOLERANCES IN DIMENSIONS PER SECTION 708.

TYPICAL FOR DRAINAGE APPLICATIONS.

UNITS SHOWN IN BRACKETS [] ARE METRIC AND ARE IN MILLIMETERS (mm) UNLESS OTHER UNITS ARE SHOWN.

DETAILED DRAWING
REFERENCE DWG. NO.
STANDARD SPEC. 603-24
SECTION 603.708

REINFORCED CONCRETE
PIPE JOINT

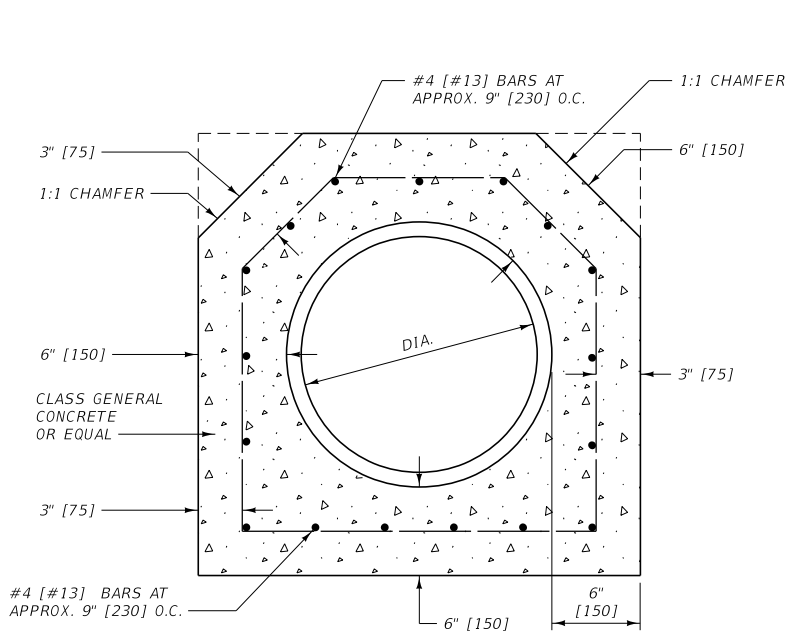

SECTION A-A

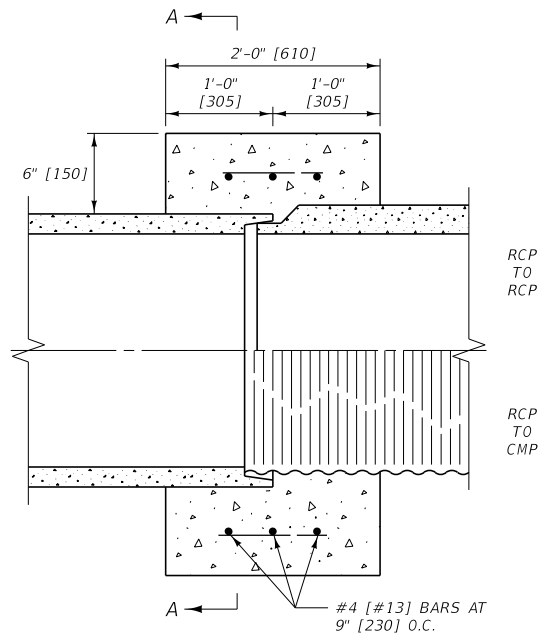

CONNECTION DETAILS

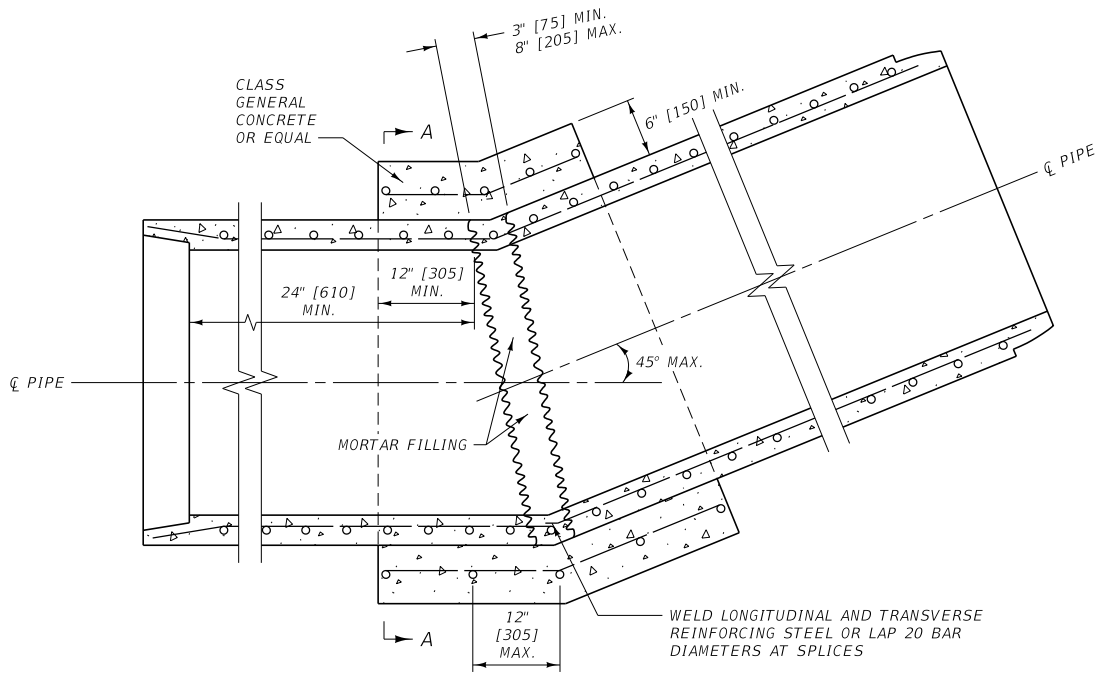

TYPICAL FIELD CAST CONCRETE BEND

DETAILED DRAWING	
REFERENCE STANDARD SPEC. SECTION 603.708	DWG. NO. 603-26

TYPICAL FIELD CAST CONCRETE CONNECTIONS

UNITS SHOWN IN BRACKETS [] ARE METRIC AND ARE IN MILLIMETERS (mm) UNLESS OTHER UNITS ARE SHOWN.

ADAPTER RING - TIE BOLT DETAIL

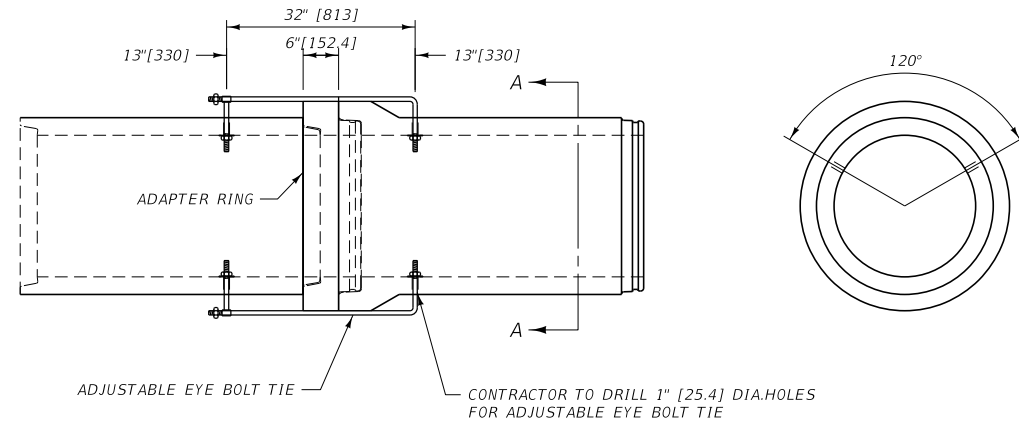

PLAN VIEW

SECTION A-A

NOTES:

- ① PART NUMBER 11051-A FURNISH WITH ADJUSTING NUT ONLY, ALL OTHERS AS SHOWN
- ② BOLTS PAINTED WITH ZINC CHROMATE IRON OXIDE
- ③ PAINT STANDARD ROLLED THREADS ON ALL BOLTS
- ④ RODS MAY BE HOT BENT
- ⑤ FOR 18" [457] RCP USE 42-54 EYE BOLT TIE
- ⑥ FOR 24" [610] RCP USE 60-66 EYE BOLT TIE

ADJUSTABLE EYE BOLT TIE

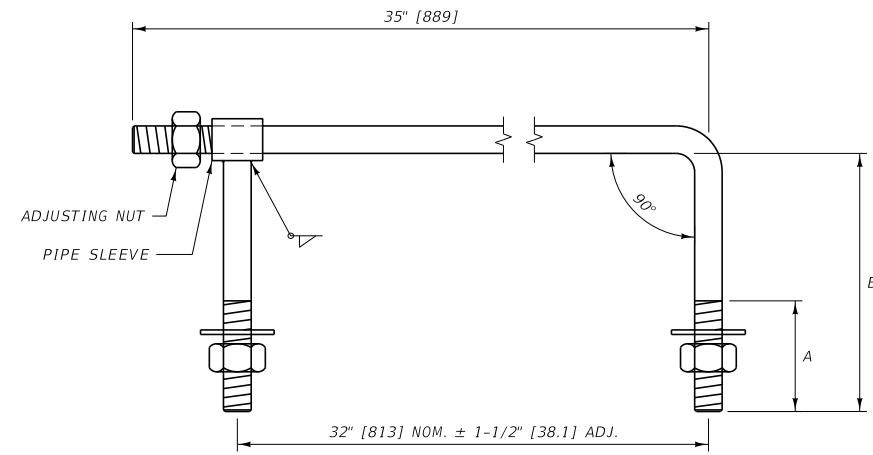

PART NO.	PIPE SIZE *	WALL THK.	P/N	THREAD DIA.	A		ROD DIA.
					in	in	
11051-A	12"-27"	2"-3.5"	091000	5/8"	0	4	9/16"
11051-D	30"-36"	3.5"-4"	091004	3/4"	3	5.5	11/16"
11051-G	42"-54"	4.5"-5.5"	091008	3/4"	3	7	11/16"
11051-J	60"-66"	6"-6.5"	091012	3/4"	3	8.5	11/16"
11051-M	72"-84"	7"-8"	091016	1"	3	10.5	29/32"
11051-O	90"-102"	8.5"-9.5"	091019	1"	3	12	29/32"
11051-Q	108"-120"	10"	091022	1"	3	13	29/32"

* BASED ON 'B' WALL ROUND PIPE AND EQUIVALENT SIZE ARCH PIPE

PART NO.	PIPE SIZE *	WALL THK.	P/N	THREAD DIA.	A		ROD DIA.
					mm	mm	
11051-A	300-675	50.8-88.9	091000	15.88	0.0	101.6	14.29
11051-D	750-900	88.9-101.6	091004	19.05	76.2	139.7	17.46
11051-G	1050-1350	114.3-139.7	091008	19.05	76.2	177.8	17.46
11051-J	1500-1650	152.4-165.1	091012	19.05	76.2	215.9	17.46
11051-M	1800-2100	177.8-203.2	091016	25.4	76.2	266.7	23.02
11051-O	2250-2550	215.9-241.3	091019	25.4	76.2	304.8	23.02
11051-Q	2700-3000	254.0	091022	25.4	76.2	330.2	23.02

* BASED ON 'B' WALL ROUND PIPE AND EQUIVALENT SIZE ARCH PIPE

18" [457] CTX ADAPTER RING

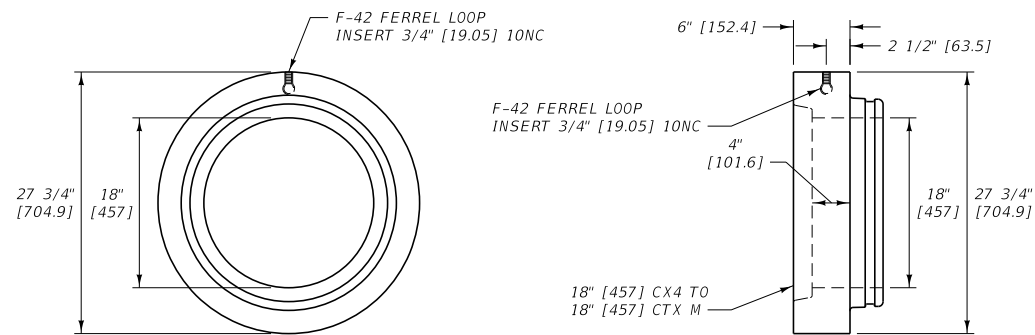

24" [610] CTX ADAPTER RING

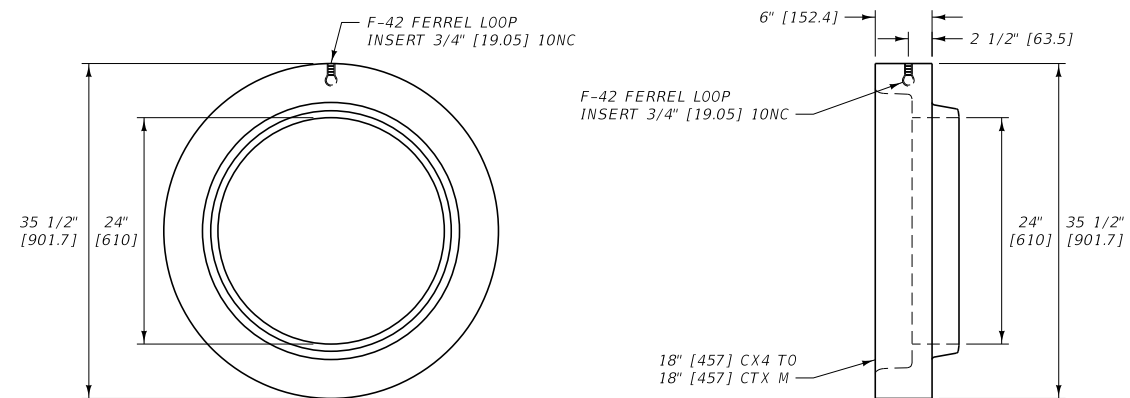
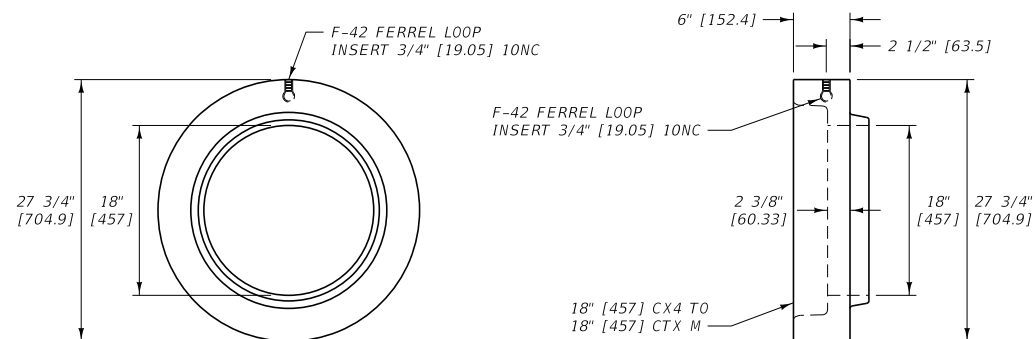
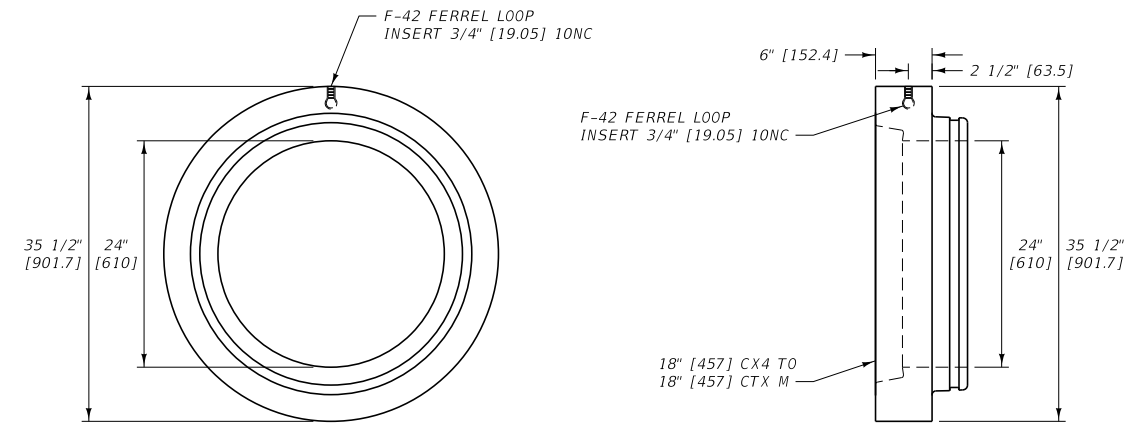

NOTES:

- ① PRODUCED PER ASTM C76
- ② CL5 REINFORCING, TYPE 5 CEMENT

UNITS SHOWN IN BRACKETS [] ARE METRIC AND ARE IN MILLIMETERS (mm) UNLESS OTHER UNITS ARE SHOWN.

REFERENCE DWG. NO.
STANDARD SPEC. 603-27
SECTION 603

DETAILED DRAWING

CTX ADAPTER

NOTE:
DASHED ARROWS DENOTE
DIRECTION OF WATER FLOW.

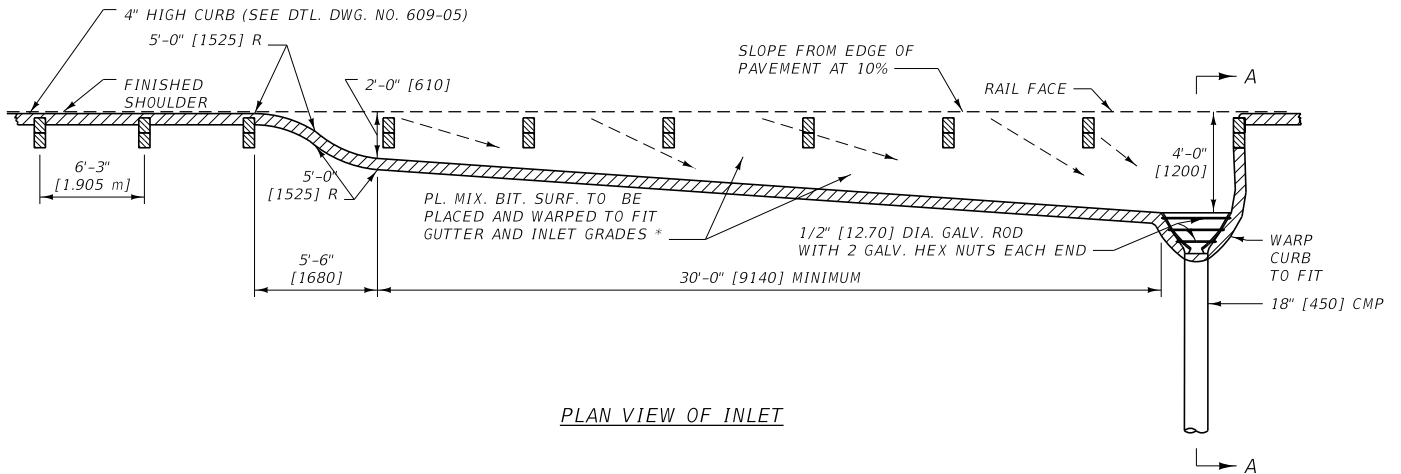

PLAN VIEW OF INLET

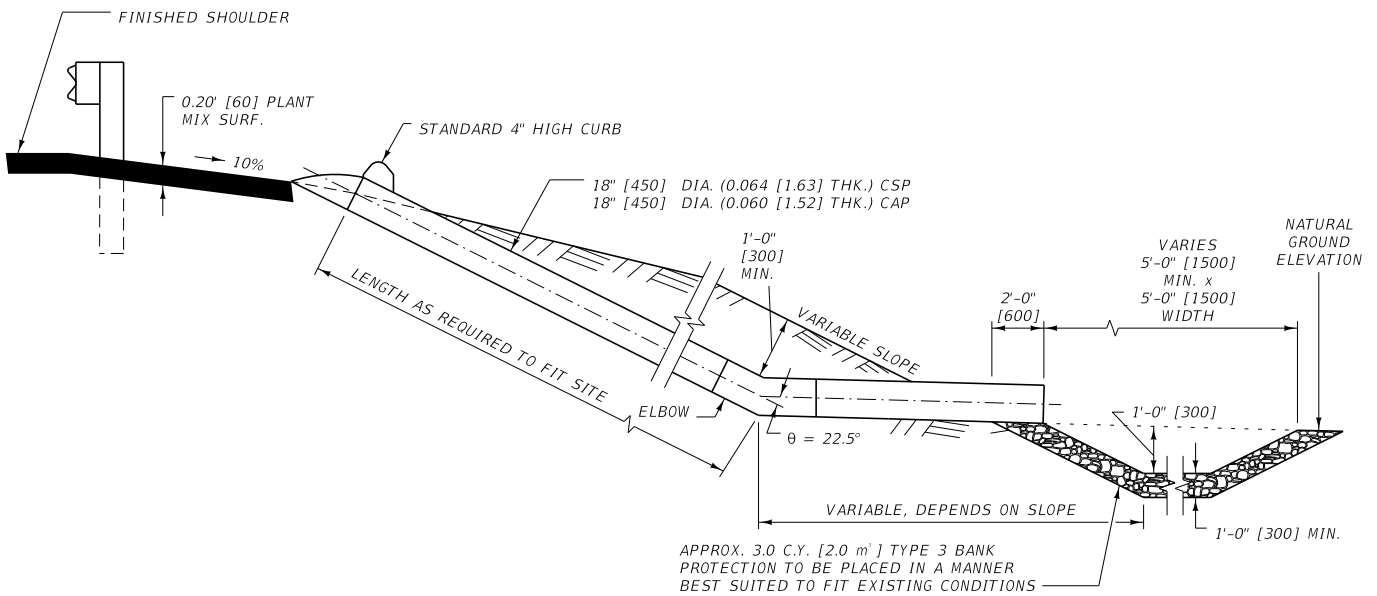

OUTLET DETAIL

SECTION A-A

NOTES:

- ① CORRUGATION MAY BE EITHER ANNULAR OR HELICAL. BEND ON ELBOW (θ) IS AS SHOWN UNLESS OTHERWISE SPECIFIED IN THE PLANS OR BY THE PROJECT MANAGER.

* INCLUDED WITH ROADWAY QUANTITIES.

UNITS SHOWN IN BRACKETS [] ARE METRIC AND ARE IN MILLIMETERS (mm) UNLESS OTHER UNITS ARE SHOWN.

DETAILED DRAWING	
REFERENCE STANDARD SPEC. SECTION 603	DWG. NO. 603-28
EMBANKMENT PROTECTOR	
MDT MONTANA DEPARTMENT OF TRANSPORTATION	

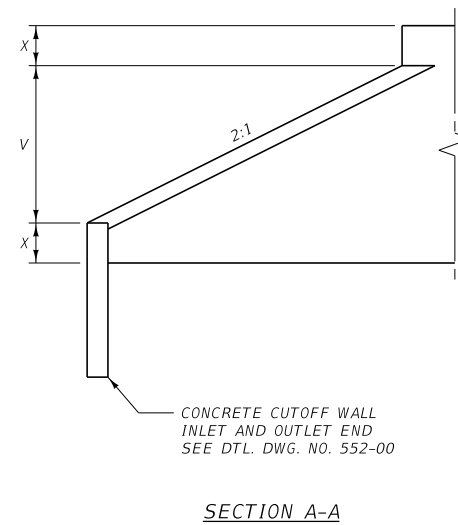
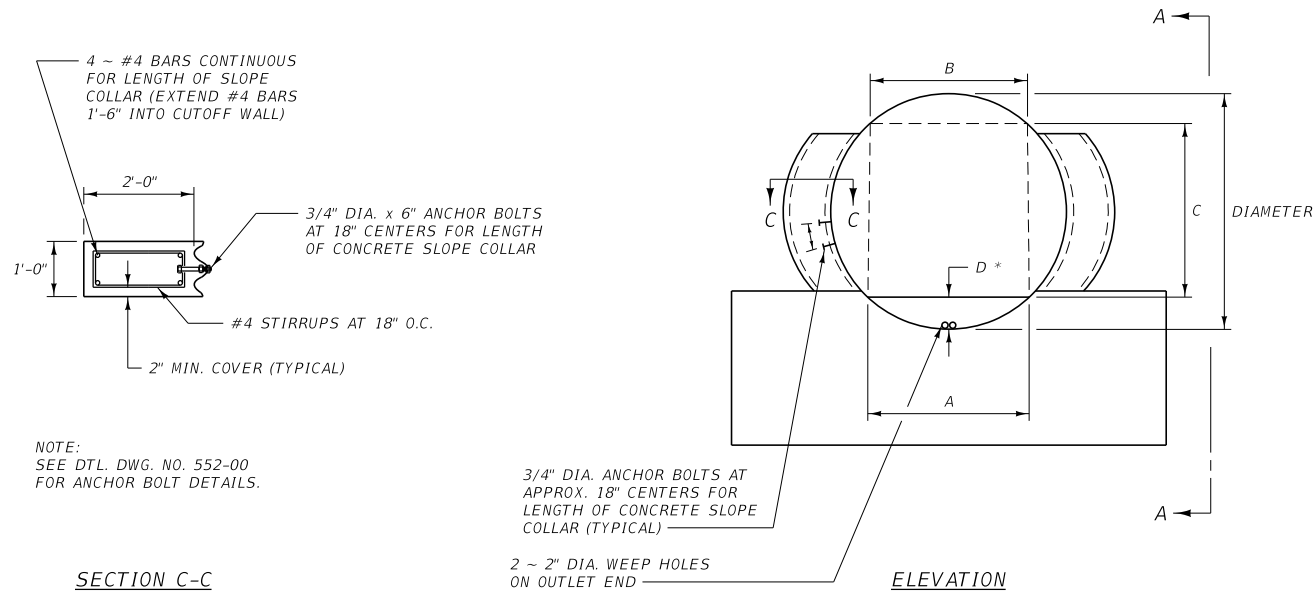

- NOTES:
- DESIGNATE THESE STRUCTURES, IN PLANS AND PROPOSAL, AS "VEHICULAR UNDERPASS." USE THE TERM "VEHICULAR UNDERPASS," REGARDLESS OF THE USE OR PURPOSE OF THE STRUCTURE.
 - PROVIDE END TREATMENT FOR ALL VEHICULAR UNDERPASSES INCLUDING CUTOFF WALLS, BACKFILL RETAINING WALLS AND CONCRETE SLOPE COLLARS.
 - PROVIDE SURFACING FOR THE INSIDE OF THE STRUCTURE, CROSS-SLOPED TO ALLOW A DRAINAGE COURSE DOWN THE CENTERLINE.
 - FOR PLATE THICKNESS SEE ROAD DESIGN MANUAL FILL HEIGHT TABLES.
 - USE CLASS GENERAL CONCRETE OR EQUAL.
 - SEE DTL. DWG. NO. 552-08 FOR QUANTITIES.
 - SEE DTL. DWG. NO. 603-31 FOR ALTERNATIVE "C" PCCP TRANSVERSE JOINT AND BACKFILL RETAINER DETAILS.

NOTE:
SEE DTL. DWG. NO. 552-00
FOR ANCHOR BOLT DETAILS.

3/4" DIA. ANCHOR BOLTS AT APPROX. 18" CENTERS FOR LENGTH OF CONCRETE SLOPE COLLAR (TYPICAL)
2 - 2" DIA. WEEP HOLES ON OUTLET END

CONCRETE CUTOFF WALL INLET AND OUTLET END SEE DTL. DWG. NO. 552-00

DEPTH OF SURFACING *			
MATERIAL	ALTERNATE "A"	ALTERNATE "B"	ALTERNATE "C"
PL. MIX SURF.	—	0.20'	—
PORT. CEM. CONC. PAVE.	—	—	0.67'
CRUSHED AGGREGATE COURSE	BAL.	BAL.	BAL.

DIAMETER	A	B	C	V	X	D *	BACKFILL RETAINER (C.Y.)	CONCRETE COLLAR (C.Y.)
96"	4'	4'	6.9'	4.0'	2.0'	0.5'	0.04	0.66
120"	7'	7'	7.1'	5.0'	2.5'	1.4'	0.17	0.82
150"	10'	8'	8.6'	6.25'	3.13'	2.5'	0.43	1.08
162"	10'	8'	10.0'	6.75'	3.38'	2.2'	0.38	1.16
186"	12'	10'	10.8'	7.75'	3.88'	2.9'	0.59	1.34
192"	12'	10'	11.5'	8.0'	4.0'	2.7'	0.55	1.38
204"	12'	10'	12.9'	8.5'	4.25'	2.5'	0.51	1.46
216"	12'	10'	14.2'	9.0'	4.50'	2.3'	0.47	1.54
228"	16'	12'	12.5'	9.5'	4.75'	4.4'	1.23	1.72
240"	16'	12'	14.0'	10.0'	5.0'	4.0'	1.10	1.72

DIAMETER	SURFACING QUANTITIES PER LINEAR FOOT FOR DEPTH "D" *								
	ALTERNATE "A"		ALTERNATE "B"				ALTERNATE "C"		
	C.Y. SURFACING	TONS SURFACING	C.Y. SURFACING	TONS BIT. MATL.		C.Y. SURFACING	S.Y. SURFACING		
96"	0.054	0.0056	0.052	0.027	0.0031	0.0005	0.0007	—	0.444
120"	0.255	0.0097	0.097	0.205	0.0058	0.0009	0.0012	0.096	0.778
150"	0.647	0.0139	0.141	0.574	0.0084	0.0014	0.0017	0.413	1.111
162"	0.563	0.0139	0.140	0.489	0.0084	0.0014	0.0017	0.332	1.111
186"	0.882	0.0167	0.169	0.794	0.0102	0.0017	0.0020	0.615	1.333
192"	0.830	0.0167	0.168	0.744	0.0101	0.0016	0.0020	0.550	1.333
204"	0.769	0.0167	0.169	0.680	0.0102	0.0016	0.0020	0.486	1.333
216"	0.702	0.0167	0.168	0.615	0.0101	0.0016	0.0020	0.423	1.333
228"	1.842	0.0222	0.227	1.725	0.0136	0.0022	0.0026	1.453	1.778
240"	1.656	0.0222	0.226	1.539	0.0136	0.0022	0.0026	1.273	1.778

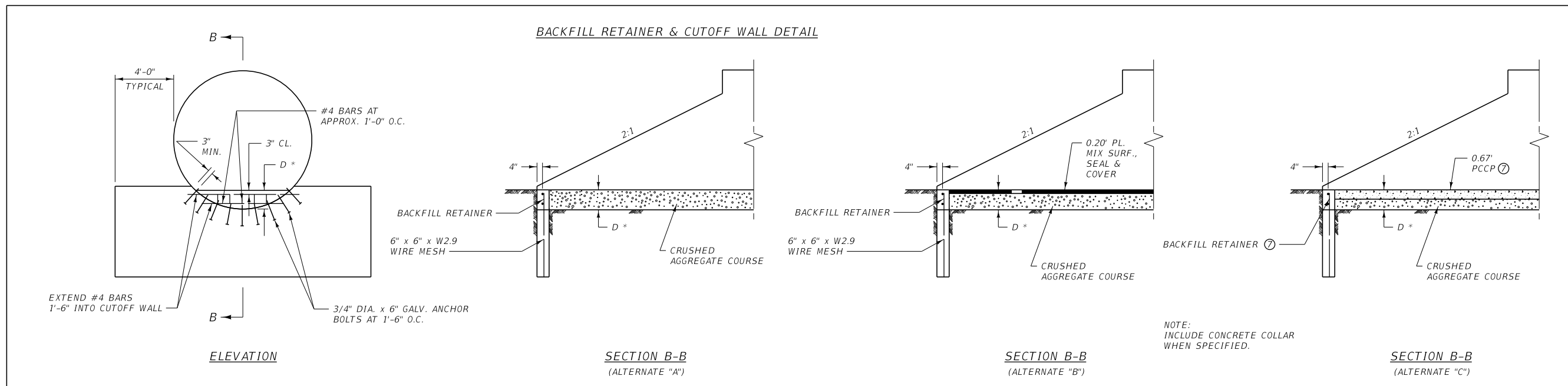

NOTE:
INCLUDE CONCRETE COLLAR WHEN SPECIFIED.

DETAILED DRAWING
REFERENCE DWG. NO. STANDARD SPEC. SECTION 552.603 603-30
VEHICULAR UNDERPASS AND BACKFILL RETAINER & CUTOFF WALL DETAIL

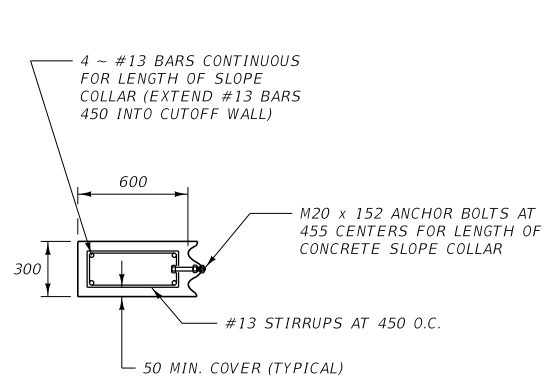

NOTE:
SEE DTL. DWG. NO. 552-00
FOR ANCHOR BOLT DETAILS.

SECTION C-C

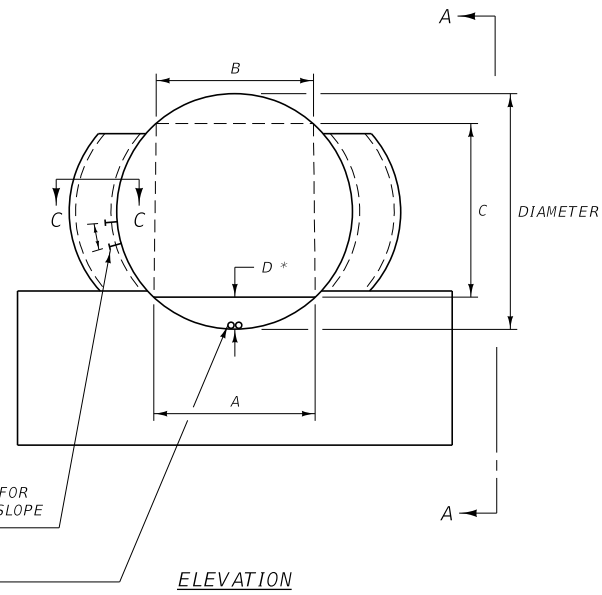

M20 ANCHOR BOLTS AT
APPROX. 455 CENTERS FOR
LENGTH OF CONCRETE SLOPE
COLLAR (TYPICAL)

ELEVATION

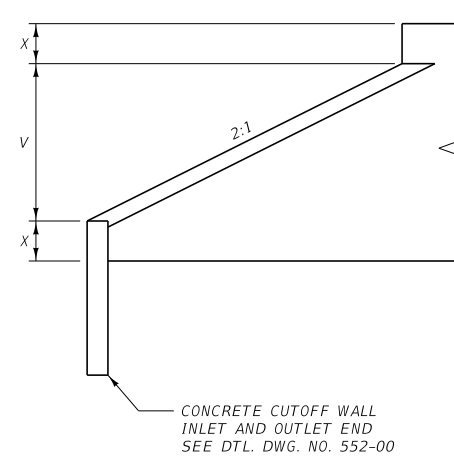

SECTION A-A

NOTES:

- ① DESIGNATE THESE STRUCTURES, IN PLANS AND PROPOSAL, AS "VEHICULAR UNDERPASS." USE THE TERM "VEHICULAR UNDERPASS," REGARDLESS OF THE USE OR PURPOSE OF THE STRUCTURE.
- ② PROVIDE END TREATMENT FOR ALL VEHICULAR UNDERPASSES INCLUDING CUTOFF WALLS, BACKFILL RETAINING WALLS AND CONCRETE SLOPE COLLARS.
- ③ PROVIDE SURFACING FOR THE INSIDE OF THE STRUCTURE, CROSS-SLOPED TO ALLOW A DRAINAGE COURSE DOWN THE CENTERLINE.
- ④ FOR PLATE THICKNESS SEE ROAD DESIGN MANUAL FILL HEIGHT TABLES.
- ⑤ USE CLASS GENERAL CONCRETE OR EQUAL.
- ⑥ SEE DTL. DWG. NO. 552-08 FOR QUANTITIES.
- ⑦ SEE DTL. DWG. NO. 603-31 FOR ALTERNATIVE "C" PCCP TRANSVERSE JOINT AND BACKFILL RETAINER DETAILS.

DEPTH OF SURFACING *			
MATERIAL	ALTERNATE "A"	ALTERNATE "B"	ALTERNATE "C"
PL. MIX SURF.	—	60	—
PORT. CEM. CONC. PAVE.	—	—	203
CRUSHED AGGREGATE COURSE	BAL.	BAL.	BAL.

DIAMETER	A (m)	B (m)	C (m)	V (m)	X (m)	D *	BACKFILL RETAINER (m ²)	CONCRETE COLLAR (m ²)
2400	1.2	1.2	2.078	1.200	0.600	173	0.03	0.50
3000	2.1	2.1	2.142	1.500	0.750	441	0.13	0.63
3.825 m	3.0	2.4	2.683	1.916	0.957	750	0.32	0.80
4.135 m	3.0	2.4	3.114	2.071	1.035	669	0.28	0.87
4.755 m	3.6	3.0	3.407	2.381	1.190	848	0.43	1.00
4.910 m	3.6	3.0	3.622	2.459	1.229	809	0.41	1.03
5.220 m	3.6	3.0	4.035	2.613	1.307	744	0.38	1.10
5.530 m	3.6	3.0	4.431	2.770	1.384	690	0.35	1.16
5.840 m	4.8	3.6	3.975	2.924	1.462	1279	0.87	1.23
6.150 m	4.8	3.6	4.428	3.079	1.540	1176	0.80	1.29

DIAMETER	SURFACING QUANTITIES PER METER FOR DEPTH "D" *								
	ALTERNATE "A"		ALTERNATE "B"				ALTERNATE "C"		
	m ³ SURFACING	TONS SURFACING	m ³ SURFACING	TONS BIT. MATL.			m ³ SURFACING	m ² SURFACING	
	CRUSHED AGGREGATE COURSE	COVER MATERIAL	PLANT MIX	CRUSHED AGGREGATE COURSE	PLANT MIX	PRIME	SEAL	CRUSHED AGGREGATE COURSE	PORT. CEM. CONCRETE PAVEMENT
2400	0.147	0.0175	0.158	0.078	0.0095	0.0015	0.0020	—	1.200
3000	0.649	0.0299	0.284	0.525	0.0170	0.0029	0.0034	0.259	2.100
3.825 m	1.604	0.0429	0.414	1.423	0.0248	0.0042	0.0049	0.998	3.000
4.135 m	1.420	0.0430	0.414	1.239	0.0248	0.0042	0.0049	0.822	3.000
4.755 m	2.159	0.0513	0.496	1.942	0.0298	0.0051	0.0059	1.429	3.600
4.910 m	2.056	0.0514	0.496	1.839	0.0298	0.0051	0.0059	1.327	3.600
5.220 m	1.882	0.0514	0.496	1.665	0.0298	0.0051	0.0059	1.159	3.600
5.530 m	1.741	0.0515	0.496	1.524	0.0298	0.0050	0.0059	1.023	3.600
5.840 m	4.368	0.0681	0.661	4.079	0.0397	0.0068	0.0078	3.372	4.800
6.150 m	3.985	0.0681	0.661	3.696	0.0397	0.0068	0.0078	2.998	4.800

BACKFILL RETAINER & CUTOFF WALL DETAIL

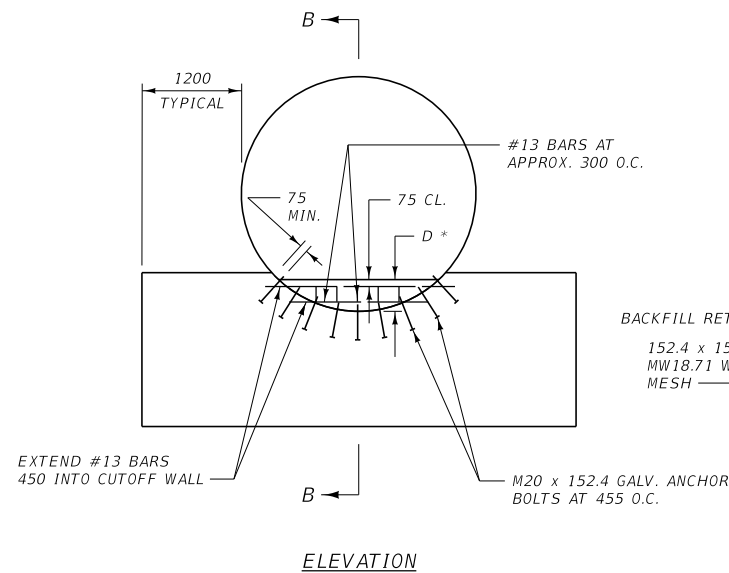

ELEVATION

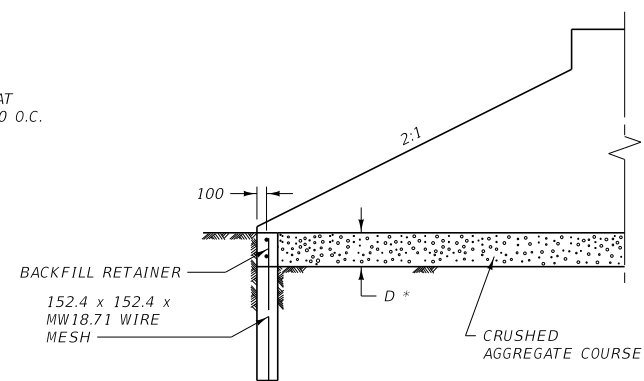

SECTION B-B
(ALTERNATE "A")

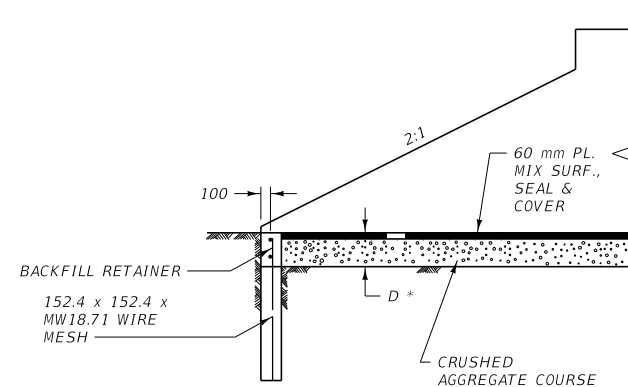

NOTE:
INCLUDE CONCRETE COLLAR
WHEN SPECIFIED.

SECTION B-B
(ALTERNATE "C")

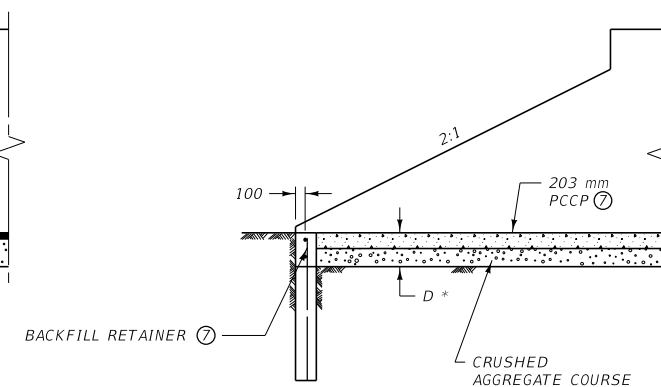

ALL DIMENSIONS ARE MILLIMETERS
(mm) UNLESS OTHERWISE NOTED.

DETAILED DRAWING	
REFERENCE STANDARD SPEC. SECTION 552.603	DWG. NO. 603-30
VEHICULAR UNDERPASS AND BACKFILL RETAINER & CUTOFF WALL DETAIL (METRIC)	

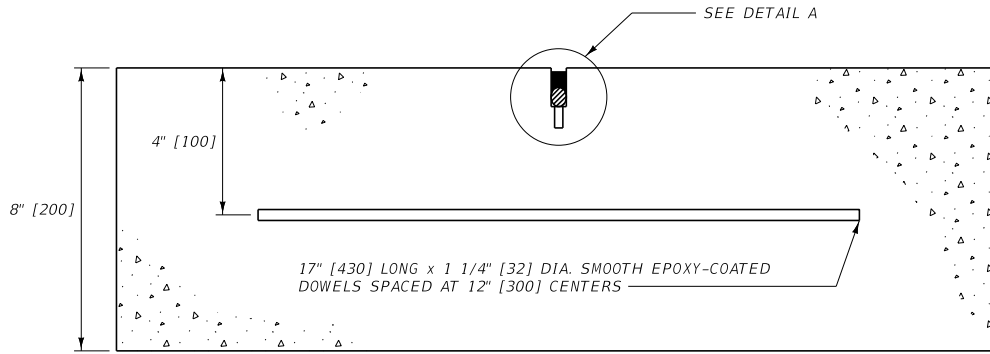

TRANSVERSE CONTRACTION JOINT (15' [4.5 m] O.C.)

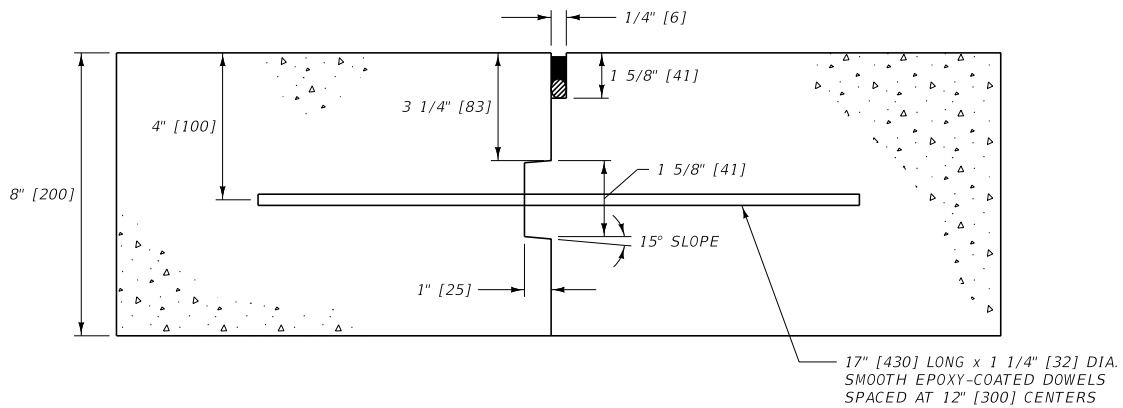

TRANSVERSE CONTRACTION JOINT (AS NEEDED)

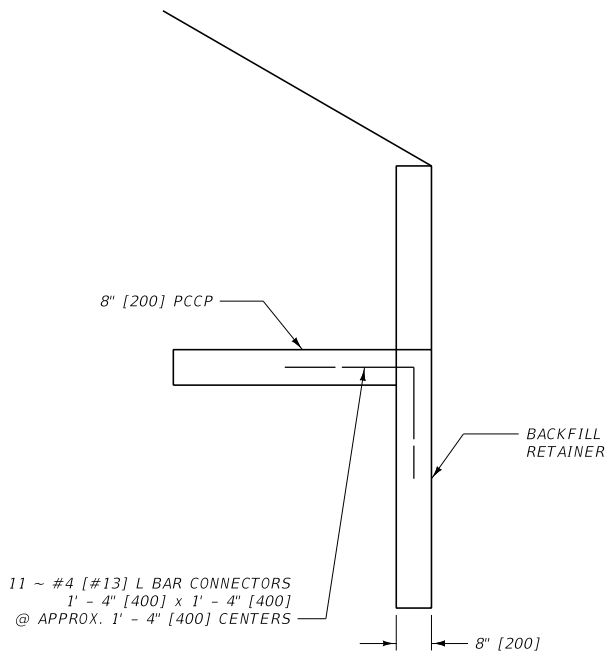

TYPICAL BOTH ENDS

REINFORCING STEEL FOR INLET
BACKFILL RETAINER @ PCCP SLAB

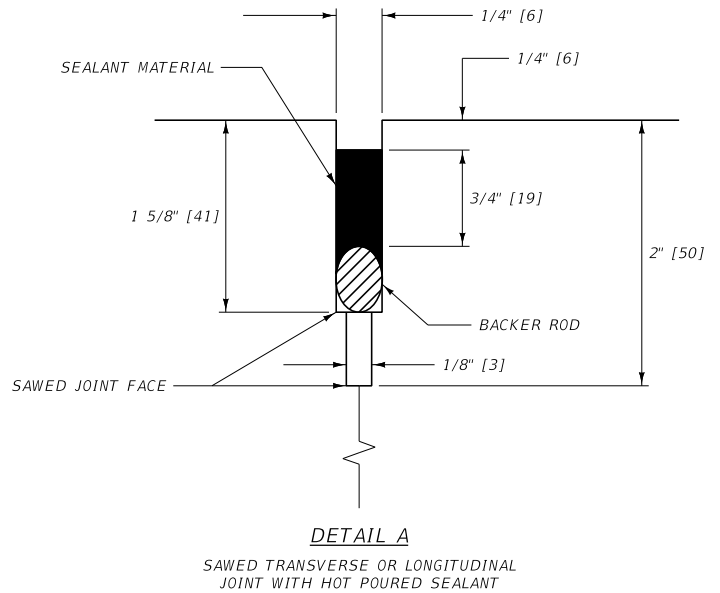

DETAIL A

SAWED TRANSVERSE OR LONGITUDINAL
JOINT WITH HOT POURED SEALANT

DETAILED DRAWING	
REFERENCE	DWG. NO.
STANDARD SPEC.	603-31
SECTION 603	
VEHICULAR UNDERPASS PCCP TRANSVERSE JOINT & BACKFILL RETAINER DETAILS	
 MONTANA DEPARTMENT OF TRANSPORTATION	

UNITS SHOWN IN BRACKETS [] ARE
METRIC AND ARE IN MILLIMETERS (mm)
UNLESS OTHER UNITS ARE SHOWN.

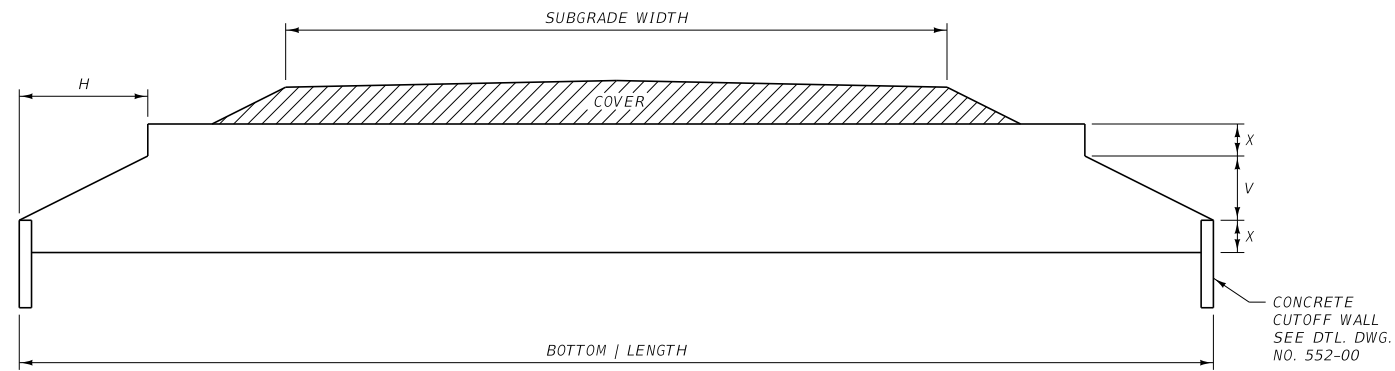

DIMENSIONS						
DIA.	X (FT.)	V (FT.)	H (FT.) FOR BEVELS:		AREA "A" (SQ. FT.) *	AREA "B" (SQ. FT.)
			1.5:1	2:1		
CSP 3" x 1" OR 5" x 1" CORRUGATIONS (SEE NOTE ③)						
54"	1.125	2.250	3.375	4.500	3	13
60"	1.250	2.500	3.750	5.000	4	16
66"	1.375	2.750	4.125	5.500	5	19
72"	1.500	3.000	4.500	6.000	6	23
78"	1.625	3.250	4.875	6.500	6	27
84"	1.750	3.500	5.250	7.000	8	31
90"	1.875	3.750	5.625	7.500	9	36
96"	2.000	4.000	6.000	8.000	10	40
102"	2.125	4.250	6.375	8.500	11	46
108"	2.250	4.500	6.750	9.000	12	51
114"	2.375	4.750	7.125	9.500	14	57
120"	2.500	5.000	7.500	10.000	15	63
SSPP 6" x 2" CORRUGATIONS						
10'-6"	2.625	5.250	7.875	10.500	17	70
11'-0"	2.750	5.500	8.250	11.000	19	76
11'-6"	2.875	5.750	8.625	11.500	20	84
12'-0"	3.000	6.000	9.000	12.000	22	91
12'-6"	3.125	6.250	9.375	12.500	24	99
13'-0"	3.250	6.500	9.750	13.000	26	107
13'-6"	3.375	6.750	10.125	13.500	28	115
14'-0"	3.500	7.000	10.500	14.000	30	124
14'-6"	3.625	7.250	10.875	14.500	32	133
15'-0"	3.750	7.500	11.250	15.000	35	142
15'-6"	3.875	7.750	11.625	15.500	37	152
16'-0"	4.000	8.000	12.000	16.000	39	162
16'-6"	4.125	8.250	12.375	16.500	42	172
17'-0"	4.250	8.500	12.750	17.000	44	183
17'-6"	4.375	8.750	13.125	17.500	47	194
18'-0"	4.500	9.000	13.500	18.000	50	205
19'-0"	4.750	9.500	14.250	19.000	55	228
20'-0"	5.000	10.000	15.000	20.000	61	253
21'-0"	5.250	10.500	15.750	21.000	68	279

* AREA "A" IS TO THE MIDDLE OF THE CORRUGATIONS.

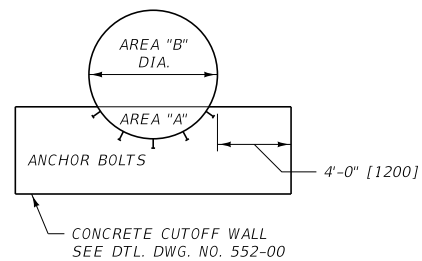

- NOTES:
- ① BEVEL TO TOP OF CORNER PLATE.
 - ② PIPE ENDS ARE SQUARE (PERPENDICULAR TO CENTERLINE OF PIPE) AND FILL SLOPES ARE WARPED TO ACCOMMODATE THE SQUARE ENDS UNLESS SPECIFIED OTHERWISE ON PLANS.
 - ③ TABULATED VALUES BASED ON NOMINAL PIPE DIMENSIONS. IN PLACE DIMENSIONS SUBJECT TO TOLERANCE REQUIREMENTS OF SECTION 709.

METRIC DIMENSIONS						
DIA. #	X (m)	V (m)	H (m) FOR BEVELS:		AREA "A" (m ²) *	AREA "B" (m ²)
			1.5:1	2:1		
CSP 75 x 25 OR 125 x 25 CORRUGATIONS (SEE NOTE ③)						
1350 mm	0.345	0.685	1.030	1.370	0.28	1.21
1500 mm	0.380	0.760	1.145	1.525	0.37	1.49
1650 mm	0.420	0.840	1.255	1.675	0.46	1.77
1800 mm	0.460	0.915	1.370	1.830	0.56	2.14
1950 mm	0.495	0.990	1.485	1.980	0.56	2.51
2100 mm	0.535	1.065	1.600	2.135	0.74	2.88
2250 mm	0.570	1.145	1.715	2.285	0.84	3.34
2400 mm	0.610	1.220	1.830	2.440	0.93	3.72
2550 mm	0.650	1.295	1.945	2.590	1.02	4.27
2700 mm	0.685	1.370	2.055	2.745	1.11	4.74
2850 mm	0.725	1.450	2.170	2.895	1.30	5.30
3000 mm	0.760	1.525	2.285	3.050	1.39	5.85
SSPP 150 x 50 CORRUGATIONS						
3.150 m	0.800	1.600	2.400	3.200	1.58	6.50
3.300 m	0.840	1.675	2.515	3.355	1.77	7.06
3.450 m	0.875	1.755	2.630	3.505	1.86	7.80
3.600 m	0.915	1.830	2.745	3.660	2.04	8.45
3.750 m	0.955	1.900	2.860	3.810	2.23	9.20
3.900 m	0.990	1.980	2.970	3.960	2.42	9.94
4.050 m	1.030	2.055	3.085	4.115	2.60	10.68
4.200 m	1.065	2.135	3.200	4.265	2.79	11.52
4.350 m	1.105	2.210	3.315	4.420	2.97	12.36
4.500 m	1.145	2.285	3.430	4.570	3.25	13.19
4.650 m	1.180	2.360	3.545	4.725	3.44	14.12
4.800 m	1.220	2.440	3.660	4.875	3.62	15.05
4.950 m	1.255	2.515	3.770	5.030	3.90	15.98
5.100 m	1.295	2.590	3.885	5.180	4.09	17.00
5.250 m	1.335	2.665	4.000	5.335	4.37	18.02
5.400 m	1.370	2.745	4.115	5.485	4.65	19.05
5.700 m	1.450	2.895	4.345	5.790	5.11	21.18
6.000 m	1.525	3.050	4.570	6.095	5.67	23.50
6.300 m	1.600	3.200	4.800	6.400	6.32	25.92

* AREA "A" IS TO THE MIDDLE OF THE CORRUGATIONS.

NOMINAL DIAMETER

UNITS SHOWN IN BRACKETS [] ARE METRIC AND ARE IN MILLIMETERS (mm) UNLESS OTHER UNITS ARE SHOWN.

DETAILED DRAWING	
REFERENCE STANDARD SPEC. SECTION 552, 603, 709	DWG. NO. 603-32
STEP BEVEL FOR CIRCULAR METAL CULVERT	

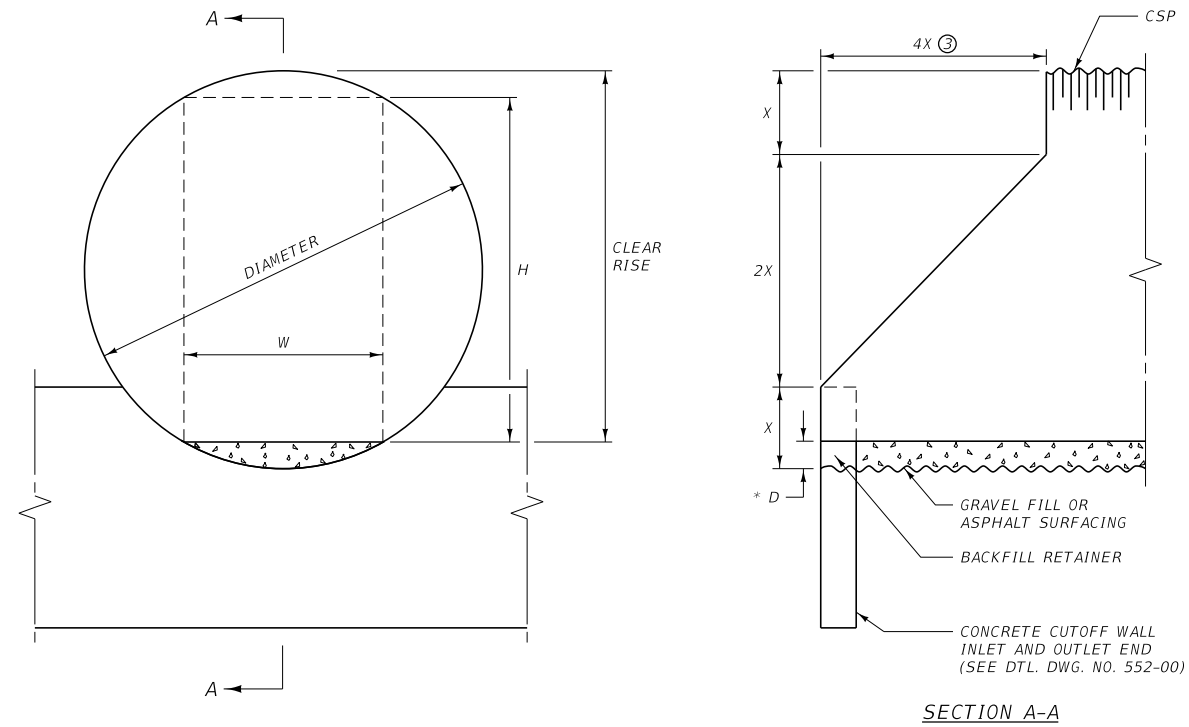

DIMENSIONS						
DIAMETER	X	* D	CLEAR RISE	H	W	BACKFILL RETAINER (CUBIC YARDS)
84"	21.0"	0.50'	6.5'	6.0'	3.6'	0.1
90"	22.5"	0.75'	6.75'	6.0'	4.5'	0.1
96"	24.0"	0.83'	7.17'	6.34'	4.9'	0.1

METRIC DIMENSIONS						
DIAMETER (mm)	X (m)	* D (mm)	CLEAR RISE (m)	H (m)	W (m)	BACKFILL RETAINER (m ³)
2100	0.525	168	1.944	1.789	1.1	0.03
2250	0.563	257	2.006	1.761	1.4	0.05
2400	0.600	276	2.137	1.873	1.5	0.06

* SURFACING QUANTITIES PER LINEAR FOOT FOR DEPTH "D"					
DIAMETER	FULL DEPTH GRAVEL		0.20' PMS AND REMAINING DEPTH GRAVEL		
	C.Y. SURF.	TONS SURF.	C.Y. SURF.	PLANT MIX	PRIME
84"	0.045	0.046	0.021	0.0028	0.0004
90"	0.085	0.060	0.054	0.0036	0.0006
96"	0.102	0.066	0.068	0.0040	0.0006

- NOTES:
- UNLESS OTHERWISE SPECIFIED, INSTALL STOCKPASSES WITH CUTOFF WALLS AND BACKFILL RETAINERS AT EACH END, GRAVEL FILL AND GRANULAR BEDDING.
 - WHEN COMBINATION STOCKPASSES AND DRAINS ARE SPECIFIED, INSTALL WITH CUTOFF WALLS, BACKFILL RETAINERS AT BOTH ENDS, CONCRETE EDGE PROTECTION AT THE INLET END AND OUTLET END, GRANULAR BEDDING AND ASPHALT SURFACING; CROSS SLOPE ASPHALT SURFACING TO ALLOW DRAINAGE COURSE ALONG ONE SIDE. (SEE DTL. DWG. NO. 613-14 AND 613-06.)
 - STEP BEVEL PIPE ENDS AT A 2:1 SLOPE.
 - THE MINIMUM THICKNESS FOR 84" [2100] DIAMETER AND 90" [2250] DIAMETER CORRUGATED STEEL PIPE STOCKPASS IS 0.079" [2.01]. THE MINIMUM THICKNESS FOR 96" [2400] DIAMETER CORRUGATED STEEL PIPE STOCKPASS IS 0.109" [2.77]. (SEE FILL HEIGHT TABLES FOR OTHER THAN THE MINIMUM REQUIREMENTS.)
 - SEE DTL. DWG. NO. 552-00, 603-30 AND 603-19.

* METRIC SURFACING QUANTITIES PER METER FOR DEPTH "D"					
DIAMETER (mm)	FULL DEPTH GRAVEL		60 mm PMS AND REMAINING DEPTH GRAVEL		
	m ³ SURF.	TONS SURF.	m ³ SURF.	PLANT MIX	PRIME
2100	0.131	0.144	0.068	0.0086	0.0013
2250	0.253	0.188	0.171	0.0113	0.0018
2400	0.291	0.201	0.203	0.0121	0.0020

UNITS SHOWN IN BRACKETS [] ARE METRIC AND ARE IN MILLIMETERS (mm) UNLESS OTHER UNITS ARE SHOWN.

DETAILED DRAWING	
REFERENCE STANDARD SPEC. SECTION 603	DWG. NO. 603-36
CORRUGATED STEEL PIPE STOCKPASS	
MDT MONTANA DEPARTMENT OF TRANSPORTATION	