



MONTANA

Department of Transportation

May 2026

MDT Civil 3D State Kit
Subassembly and Assembly Guide

RELEASE 2026.1.0

TABLE OF CONTENTS

Table of Contents	2
Overview	4
Companion Documentation	4
MDT Civil 3D State Kit Subassemblies and Assemblies	5
MDT Subassemblies	5
MDT Subassemblies Tool Palette	5
MDT Lane	6
MDT Shoulder	14
MDT Daylight with Subbase	19
MDT Curb & Gutter	34
MDT Sidewalk	46
MDT Parameter References.....	50
MDT Offset on Surface Link	57
MDT Slope To Surface Link	60
MDT Connect Surface Slope Links	64
MDT Cut Table / MDT Fill Table.....	68
Legacy MDT Subassemblies.....	73
MDT Daylight.....	73
MDT Subbase	81
MDT Curb and Gutter.....	88
MDT Assemblies	93
MDT Subassemblies Tool Palette	93
MDT Rural 2 Lane	94
MDT Rural 4 Lane	96
MDT Rural Divided	99
MDT Urban 2 Lane – Sidewalk	104
MDT Ramp.....	107
MDT Widening.....	113
MDT Ditch Block.....	116

MDT Typical Roadway Assembly Construction	120
Assembly Build Instructions	120
Create Assembly	120
Set Subassembly Parameters and Assign References	125

OVERVIEW

This guide is an overview of the functionality and use of custom MDT Civil 3D Subassemblies and Assemblies including steps to construct a typical roadway Assembly. [MDT Civil 3D State Kit Overview – Release 2026](#) is available for review of Subassembly and Assembly State Kit Content. Common issues and recommended solutions when using assemblies and subassemblies are documented in the MDT support guide [“Missing” Subassemblies – Troubleshooting](#).

COMPANION DOCUMENTATION

[MDT Civil 3D State Kit Overview - Release 2026](#)

[“Missing” Subassemblies – Troubleshooting](#)

MDT CIVIL 3D STATE KIT SUBASSEMBLIES AND ASSEMBLIES

MDT SUBASSEMBLIES

The following custom MDT Subassemblies are included in the MDT Civil 3D 2026 State Kit for application in design. Additional custom MDT Auxiliary Subassemblies are delivered as design aids for use in evaluating designs.

MDT Subassemblies

- MDT Lane
- MDT Shoulder
- MDT Daylight with Subbase
- MDT Curb & Gutter
- MDT Sidewalk
- MDT Parameter References
- Numeric Control Line
- MDT Offset on Surface Link
- MDT Slope to Surface Link

MDT Auxiliary Subassemblies

- MDT Connect Surface Slope Links
- MDT Cut Table
- MDT Fill Table

MDT SUBASSEMBLIES TOOL PALETTE

MDT Subassemblies can be selected from the **MDT Subassemblies** or **MDT Auxiliary Subassemblies** tool palette for use in creating Assemblies for modeling of MDT roadway designs.

MDT LANE

HOW THIS SUBASSEMBLY CAN BE USED:

This subassembly creates a cross-sectional representation of a travel lane, applying the Outside or Inside Lane superelevation slope value for the corridor model's baseline alignment.

It is used for most undivided roads, or divided roads with no lane slope break on either side. It may also be used for the outside or inside lanes of divided crowned or broken-back highways.

This subassembly has the ability to extend the base and subbase layers on the inside or outside of the lane.

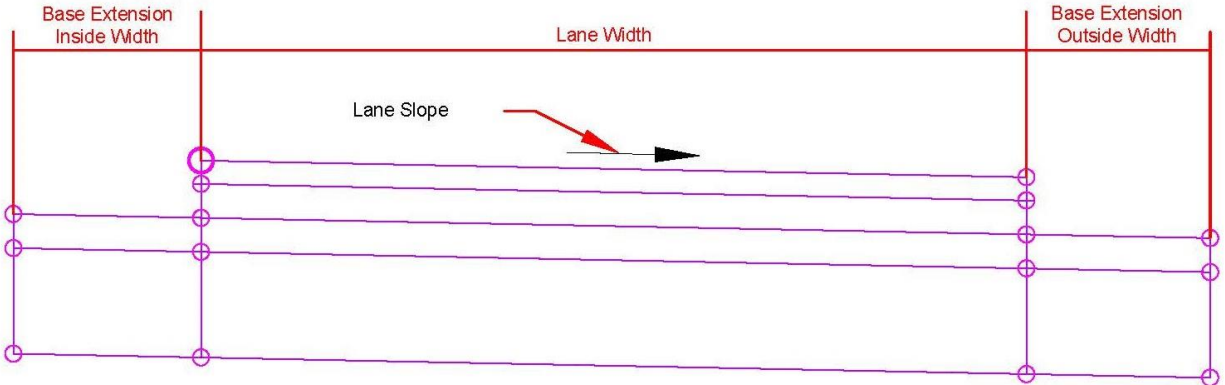

LINKS

This Subassembly creates four links as the top link of each material and a Datum link as the bottom of the Subbase. Links are also created for each extended material.

ATTACHMENT

The attachment point is at the inside edge of the lane on the finish grade surface. This component can be attached to either the left or right side.

INPUT PARAMETERS

Display Name	Description	Type	Default
Side	Specifies which side to place the subassembly	Left / Right	Right
Point Code Location Suffix	Adds a suffix to point codes.	None/Right Left/Automatic/ CustomCode	Automatic
Centerline	Location of attachment point	None/ Attachment Point/ Outside Point	Attachment Point
Lane Width	Width of the lane from the offset of the inside edge to the offset of the outside edge	Numeric, positive	12.0 ft
Lane Slope	Default slope of the lane to be used when the superelevation slope for the alignment is not defined	Numeric	-2.00%
Slope Direction	Specifies direction from centerline or direction of the crown slope	Selection List: <ul style="list-style-type: none"> Away from Crown Towards Crown 	Away from Crown
Pave 1 Depth	Thickness of the Pave1 layer (zero to omit)	Numeric, non-negative	0.3 ft
Pave 2 Depth	Thickness of the Pave2 layer (zero to omit).	Numeric, non-negative	0.0 ft
Base Depth	Thickness of the base layer (zero to omit)	Numeric, positive	0.5 ft

Display Name	Description	Type	Default
Subbase Depth	Thickness of the subbase layer (zero to omit)	Numeric, non-negative	2.0 ft
Use Superelevation	Specifies to use superelevation slope for the lane	Selection List: Left Inside Lane Slope/ Left Outside Lane Slope/ Left Inside Lane Inverse/ Left Outside Lane Inverse/ Left Inside Lane Shoulder Slope/ Left Outside Shoulder Slope/ Right Inside Lane Slope/ Right Outside Lane Slope/ Right Inside Lane Inverse/ Right Outside Lane Inverse/ Right Inside Shoulder Slope/ Right Outside Shoulder Slope/ None	None
Base Extension Inside Width	Width of base and subbase extension beyond lane width	Double	0.0
Base Extension Outside Width	Width of base and subbase extension beyond lane width	Double	0.0

Display Name	Description	Type	Default
Add Construction Slope	Adds the use of a construction slope	Selection List: <ul style="list-style-type: none"> • Yes • No 	No
Construction Slope	Value of the construction slope	Double	2.00:1
Custom Point Code Suffix	Custom Suffix characters	String	_L-In
[P1] CL Pave 1 (Attachment point)	Crown point (Centerline) on finish grade	String	CL_Pave1
[P2] Pave 1 (outside)	Outside of lane on finish grade	String	Pave1
[P3] CL Pave 2 (inside)	Crown point (Centerline) on Pave 2 grade	String	CL_Pave2
[P4] Pave 2 (outside)	Outside of lane on Pave2 grade	String	Pave2
[P5] CL Base (inside)	Crown point (Centerline) on Base grade	String	CL_Base
[P6] Base (outside)	Outside of lane on Base grade	String	Base
[P7] CL Datum, Subbase (inside)	Crown point (Centerline) on Subbase grade	String	LabelSGElevation,Datum,CL_Subbase
[P8] Datum, Subbase (outside)	Outside of lane on Subbase grade	String	Datum,Subbase

Display Name	Description	Type	Default
[P9] CL SubbaseBot (inside)	Crown point (Centerline) on Subbase bottom grade	String	CL_SubbaseBot
[P10] SubbaseBot (outside)	Outside of lane on Subbase bottom grade	String	SubbaseBot
[P11] CL Base Extension	Inside point of Base extension on Base grade	String	CL_Base_Ext
[P12] Base Extension	Outside point of Base extension on Base grade	String	Base_Ext
[P13] CL Subbase Extension	Inside point of Subbase extension on Subbase grade	String	CL_Subbase_Ext
[P14] Subbase Extension	Outside point of Subbase extension on Base grade	String	Datum, Subbase_Ext
[P15] CL SubbaseBot Extension	Inside point of Subbase extension on Subbase bottom grade	String	CL_SubbaseBot_Ext
[P16] SubbaseBot Extension	Outside point of Subbase extension on Subbase bottom grade	String	SubbaseBot_Ext
[L1] Pave finish grade	Finish grade surface, Top of Pave 1 layer	String	LabelGrade, Top, Pave1
[L2] Pave2 surface	Top of Pave 2 layer	String	Pave2
[L3] Base surface	Top of Base layer	String	Base
[L4] Datum, Subbase surface	Datum or Top of Subbase layer	String	Datum,Subbase

Display Name	Description	Type	Default
[L5] SubbaseBot surface	Bottom of Subbase bottom layer or Datum	String	SubbaseBot
[L16] Base Construction Slope	Base layer construction slope	String	Datum,Subbase
[L18] Subbase Construction Slope	Subbase layer construction slope	String	SubbaseBot
[L20] Inside Base extended surface	Inside Base extended surface	String	Base
[L21] Outside Base extended surface	Outside Base extended surface	String	Base
[L22] Inside Datum or Subbase extended surface	Inside Datum or Subbase extended surface	String	Datum,Subbase
[L23] Outside Datum or Subbase extended surface	Outside Datum or Subbase extended surface	String	Datum,Subbase
[L24] Inside SubbaseBot extended surface	Inside Subbase bottom extended surface	String	SubbaseBot
[L25] Outside SubbaseBot extended surface	Outside Subbase bottom extended surface	String	SubbaseBot
[S1] Top layer of Pavement	Top layer of Pavement	String	Pave1
[S2] Bottom layer of Pavement	Bottom layer of Pavement	String	Pave2
[S3] Base layer	Base layer	String	Base

Display Name	Description	Type	Default
[S4] Subbase layer	Subbase layer	String	Subbase
[S5] Base layer of inside extension	Base layer of inside extension	String	Base
[S6] Base layer of outside extension	Base layer of outside extension	String	Base
[S7] Subbase layer of inside extension	Base layer of outside extension	String	Subbase
[S8] Subbase layer of outside extension	Subbase layer of outside extension	String	Subbase

TARGET PARAMETERS

Display Name	Description	Status
Lane Width	May be used to override the fixed lane width and tie the edge-of-lane to an offset alignment. The following object types can be used as targets for specifying the width: alignments, polylines, feature lines, or survey figures.	Optional
ETW Elevation	May be used to override the normal lane slope and tie the outer edge of the travel lane to the elevation of a profile. The following object types can be used as targets for specifying the elevation: profiles, 3D polylines, feature lines, or survey figures.	Optional
Lane Width Control Profile	May be used to override the normal lane width and tie the outer edge of the travel lane to the elevation of a profile. The following object types can be used as targets for specifying the elevation: profiles, 3D polylines, feature lines, or survey figures.	Elevation
Lane Slope Control Profile	May be used to override the normal lane slope and tie the outer edge of the travel lane to the elevation of a	Elevation

Display Name	Description	Status
	profile. The following object types can be used as targets for specifying the elevation: profiles, 3D polylines, feature lines, or survey figures.	

OUTPUT PARAMETERS

Display Name	Description	Type
Lane Width value	Width of the lane	Numeric
Lane Slope value %	% slope of the lane	Numeric
Pave1 Depth value	Depth of top layer of pavement	Numeric
Pave2 Depth value	Depth of bottom layer of pavement	Numeric
Base Depth value	Depth of base layer	Numeric
Subbase Depth value	Depth of Subbase layer	Numeric
Inside Extension Width value	Width of inside extension	Numeric
Outside Extension Width value	Width of outside extension	Numeric

BEHAVIOR

The lane superelevation slope is obtained from the superelevation specifications for the baseline alignment. You can specify which superelevation slope is used for the lane.

Starting at the attachment point, a finish grade surface and parallel subgrade are inserted using the given width, depth, and the superelevation slope. Vertical links close the shape at either end of the lane.

If a horizontal target is assigned to the Lane Width during corridor modeling, the width of the lane will vary to match the offset of the target.

There is an option to extend the base and subbase layers beyond the width of the paved width, both on the inside and outside of the subassembly. This can be used as the base materials for attached adjacent subassemblies like a curb.

LAYOUT MODE OPERATION

In layout mode, this subassembly displays all lane links using the width and depth input parameters at the slope defined in the Default Slope parameter.

CODING DIAGRAM

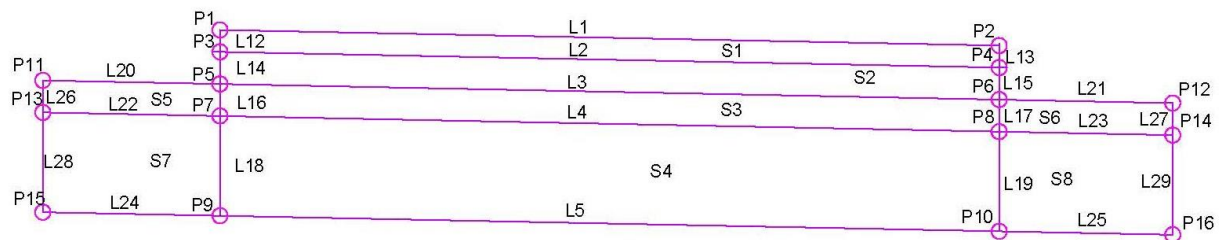

MDT SHOULDER

HOW THIS SUBASSEMBLY CAN BE USED:

This subassembly attaches to a paved shoulder with all pavement and base layers extended to the shoulder daylight slope.

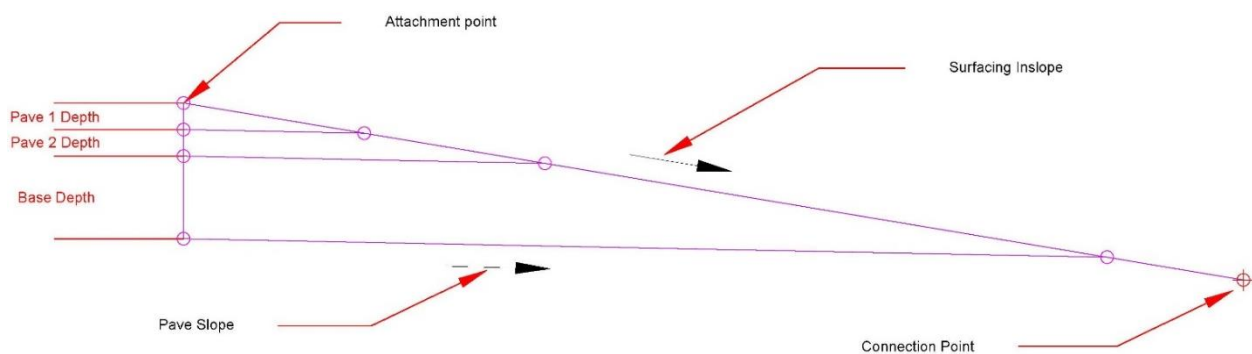

ATTACHMENT

The attachment point is at the inside edge of the paved shoulder, which is typically at the outside edge-of-traveled way.

INPUT PARAMETERS

Note: All dimensions are in feet unless otherwise noted. All slopes are in run-over-rise form (for example, 4:1) unless indicated as a percent slope with a “%” sign.

Parameter	Description	Type	Default
Side	Specifies which side to place the subassembly.	Left/Right	Right
Point Code Location Suffix	Adds a suffix to point codes.	None/Right Left/Automatic/ CustomCode	Automatic
Pave 1 Depth	Thickness of the Pave1 layer (zero to omit)	Numeric, non-negative	0.30 ft
Pave 2 Depth	Thickness of the Pave2 layer (zero to omit)	Numeric, non-negative	0.00 ft
Base Depth	Thickness of the Base layer (zero to omit)	Numeric, non-negative	0.50 ft
Pave Slope (Referenced from Lane)	Slope of the pavement	Grade	-2.00%
Normal Crown Slope	Normal crown for the roadway type	Grade	-2.00%
Surfacing Inslope	Surfacing Inslope	Numeric, positive	6:1
Use Superelevation	Specifies to use the slope from the superelevation specification defined on the baseline alignment.	None/ Left Outside Shoulder/	None

		Left Inside Shoulder/ Left Inside Lane/ Left Outside Lane/ Right Inside Shoulder/ Right Outside Shoulder/ Right Inside Lane/ <ul style="list-style-type: none"> Right Outside Lane/ 	
Inslope Extension Offset	Specifies the offset of the hinge point for an extension (safety slope)	Double	0
Geotextile Outside Edge Offset	Outermost point representing the edge of Geotextile	Double	3.0'
Custom Point Code Suffix	Custom Suffix characters	String	_L-In
[P1] Attachment point code	Attachment point	String	EOS_Pave1, LabelElevationOffset
[P2] Pave2 inside point code		String	EOS_Pave2
[P3] Pave2 inslope point code		String	Edge_Pave2
[P4] Base inside point code		String	EOS_Base
[P5] Base inslope point code		String	Edge_Base

[P6] Subbase inside point code		String	EOS_Subbase
[P7] Subbase inslope point code		String	Edge_Subbase
[P16] Hinge point code		String	LabelElevationOffset, Hinge
[P17] Geotextile Outside Edge Offset		String	Geo_Out
[L2] Pave1 inslope link code		String	
[L3] Pave2 link code		String	Pave 2
[L5] Pave2 inslope link code		String	
[L6] Base link code		String	Base
[L8] Base inslope link code		String	
[L9] Subbase link code		String	Datum, Subbase
[L10] Inslope link code		String	LabelSlope,Top
[S1] Pave1 shape code		String	Pave1

[S2] Pave2 shape code		String	Pave2
[S3] Base shape code		String	Base

OUTPUT PARAMETERS

Parameter	Description	Type
SE Base Distance Value	Distance of the bottom layer from edge of shoulder to surfacing inslope	Numeric
Normal Crown Base Distance value	Rounded distance of the bottom layer from edge of shoulder to surfacing inslope. (to nearest tenth of foot)	Numeric
SE Base Slope value	Slope of the bottom layer from edge of shoulder to hinge point	Numeric
Surfacing Inslope Value	Top slope from EOS to shoulder hinge point	Numeric
Rounded Surfacing Inslope value	Rounded top slope from EOS to shoulder hinge point	Numeric
Normal Crown Slope value	Normal crown slope	Numeric
Inslope Extension Offset value	Inslope Extension offset (safety slope)	Numeric

BEHAVIOR

The attachment point is the outside edge of shoulder. It defines the surfacing inslope.

The MDT Shoulder can be inserted with pavement depths (up to 2) and a base depth. The surfacing inslope is extended from the outside edge of the shoulder until it intersects the bottom of base. The daylight (end connection) is connected to the bottom of base.

The Pave 1, Pave 2, and Base surface links are inserted parallel to the finish grade at the given depths until they intersect with the surfacing inslope.

LAYOUT MODE OPERATION

In layout mode, this subassembly displays the links comprising the surfacing inslope for a normal crown roadway situation, using default cross slope and surfacing depths.

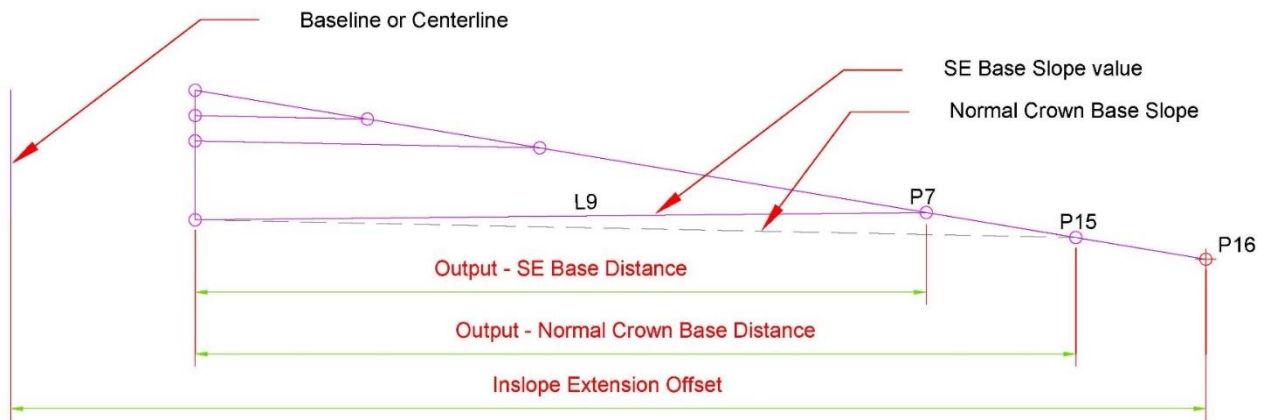

CODING DIAGRAM

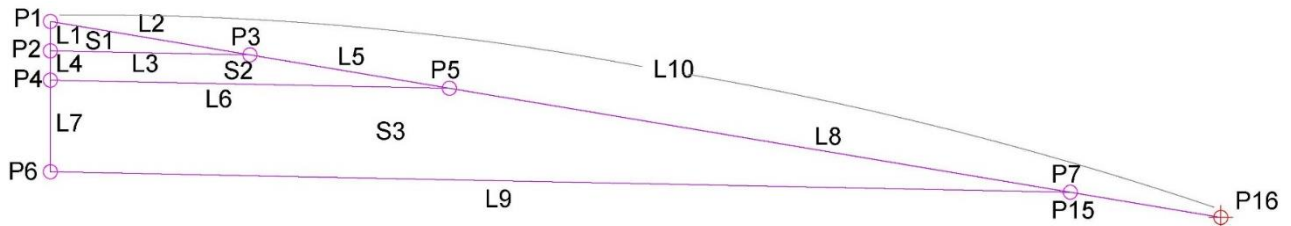

MDT DAYLIGHT WITH SUBBASE

HOW THIS SUBASSEMBLY CAN BE USED:

The MDT Daylight Subbase Subassembly can be used for roadway daylighting (end conditions) with or without subbase underneath the MDT Shoulder subassembly. This Subassembly performs calculations for both cut and fill situations to choose the appropriate slope based on cut and fill heights in relation to a target surface. The Subassembly uses parameter references of the adjacent MDT Shoulder subassembly to match the bottom of base width and slope of the shoulder.

NO SUBBASE

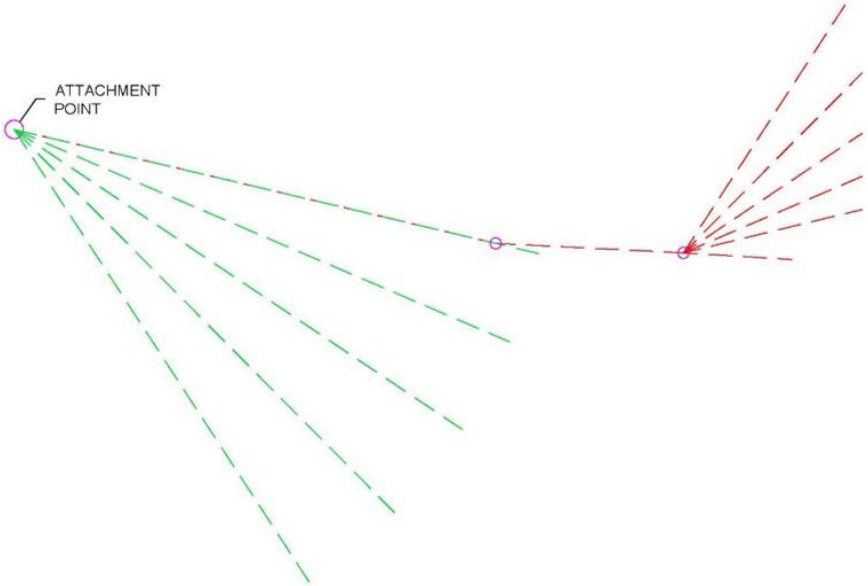

EXTENDED HINGE POINT

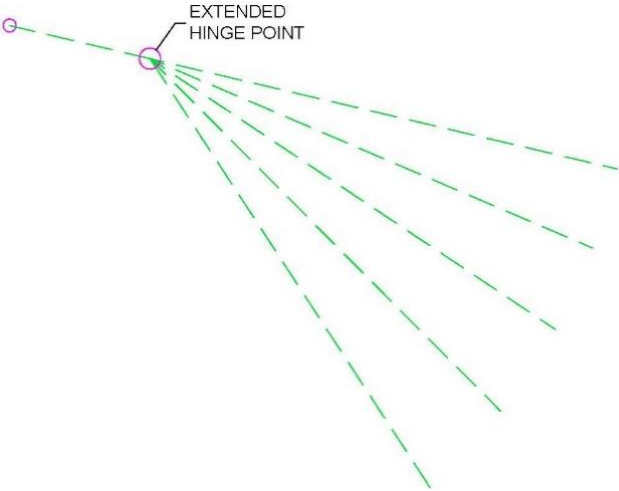

WITH SUBBASE

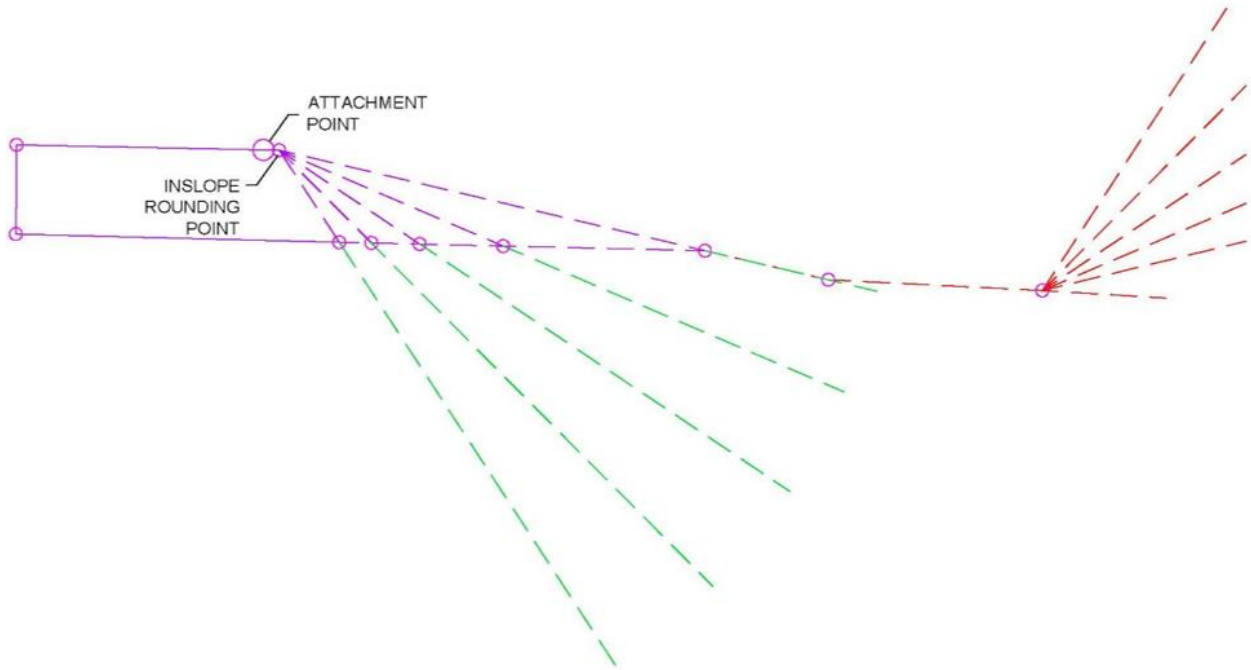

EXTENDED HINGE POINT WITH SUBBASE

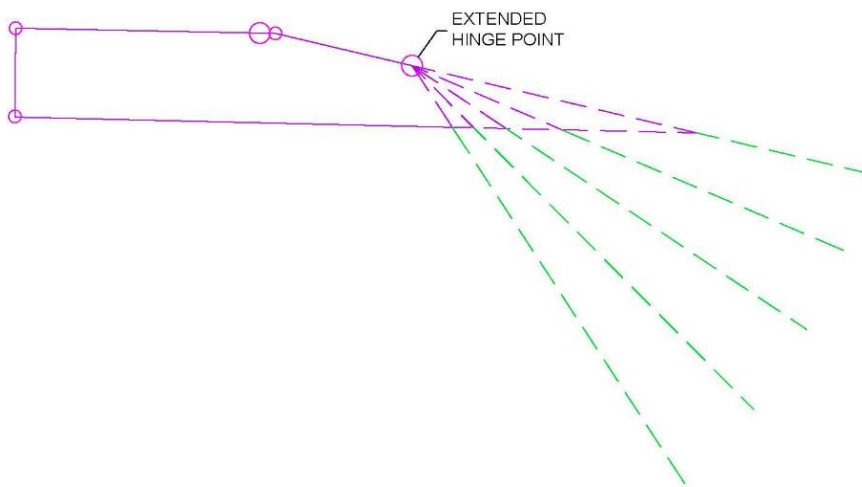

LINKS

This Subassembly creates Top, Daylight, Daylight_Cut, Daylight_Fill, Datum, Ditch, and Subbase links. A shape is created for Subbase.

DAYLIGHT CUT FORESLOPE WIDTH > SUBBASE INSLOPE WIDTH

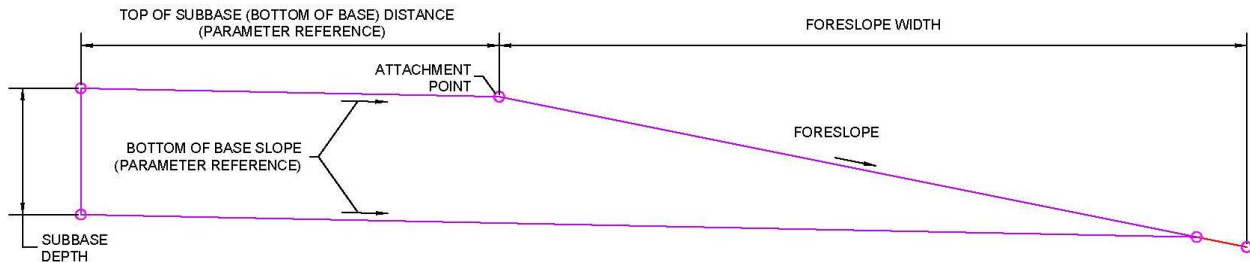

DAYLIGHT CUT – USE BATHTUB FORESLOPE WIDTH < SUBBASE INSLOPE WIDTH

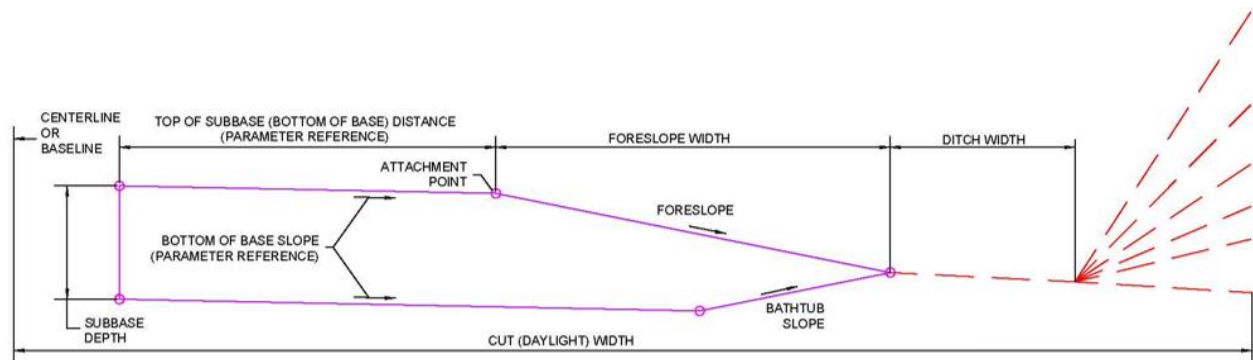

DAYLIGHT CUT FORESLOPE WIDTH < SUBBASE INSLOPE WIDTH

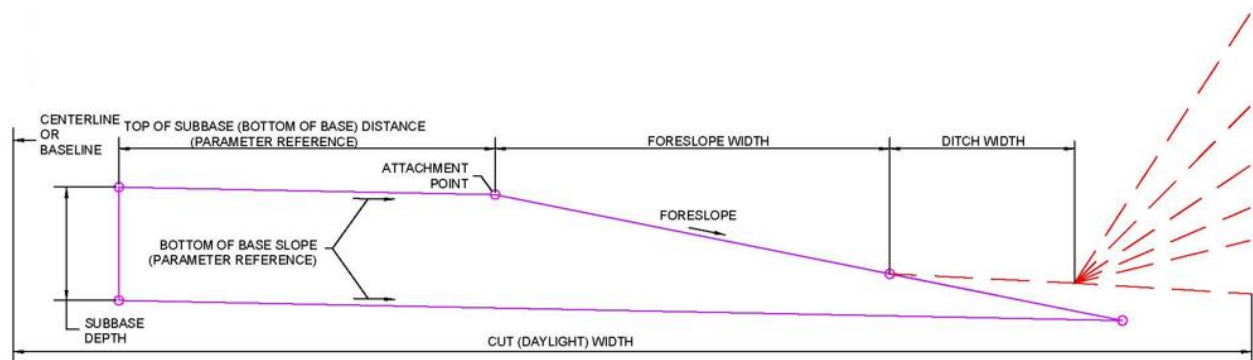

DAYLIGHT FILL

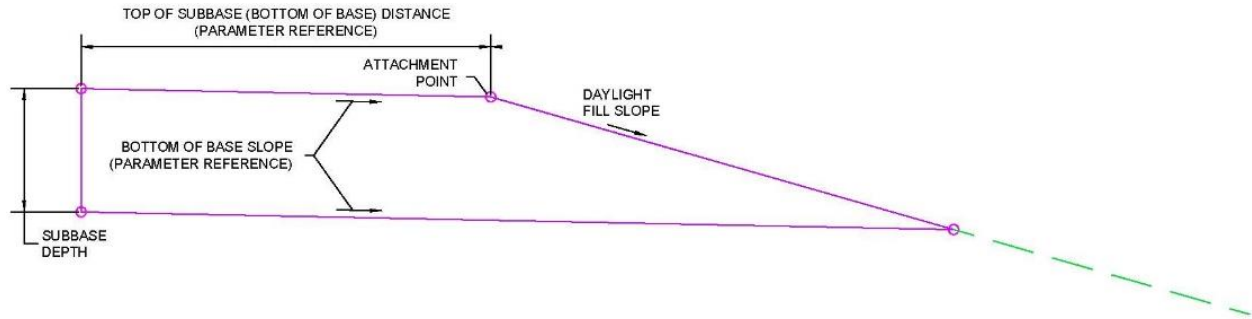

DAYLIGHT FILL WITH EXTENDED HINGE POINT > SUBBASE INSLOPE WIDTH

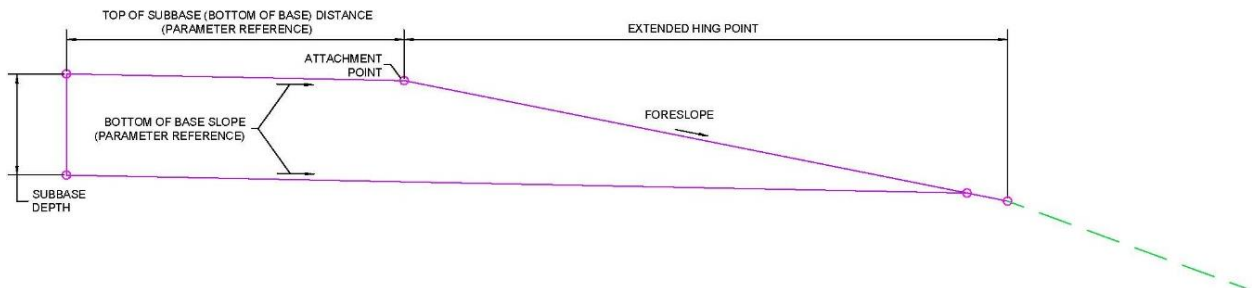

DAYLIGHT FILL WITH EXTENDED HINGE POINT < SUBBASE INSLOPE WIDTH

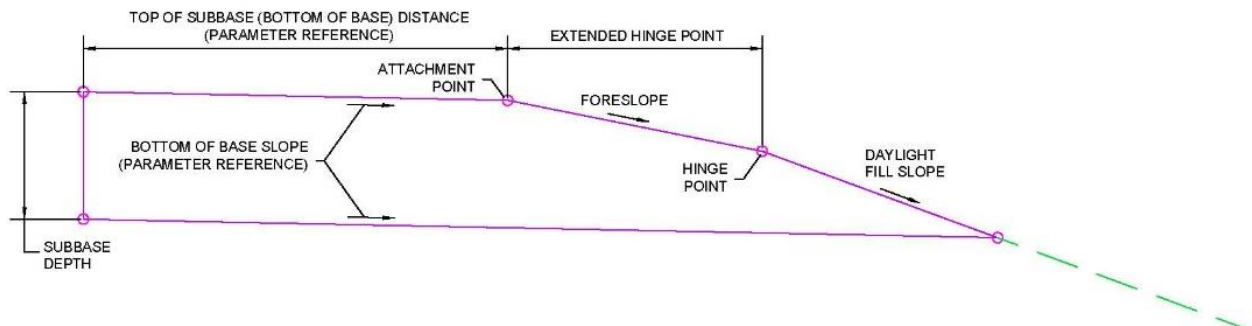

ATTACHMENT

The attachment point is as noted on the diagrams above. The attachment point is determined by the bottom of base/top of subbase.

INPUT PARAMETERS

Parameter	Description	Type	Default
Side	Specifies which side to place the Subassembly	Left / Right	Right

Parameter	Description	Type	Default
Select Subassembly build options	Options to choose Daylight with or without Subbase	<ul style="list-style-type: none"> Daylight with Subbase Daylight 	Daylight with Subbase
Point Code Location Suffix	Adds a suffix to point codes.	None/Right Left/Automatic/CustomCode	Automatic
End Condition Options	Options to choose end condition	Automatic/Cut Only/Fill Only/Day Only	Automatic
Foreslope	Slope of Foreslope in cut condition	Slope	6.00:1
Foreslope Width	Width of the Foreslope in cut condition	Double	10.0'
Ditch Slope	Slope along the width of the ditch	Slope	-20.00:1
Ditch Width	Width of the ditch	Double	10.0'
PESC Ditch Slope	Slope of PESC Ditch	Slope	1:0
PESC Ditch Width	Width of PESC Ditch	Double	6'
Minimum Ditch Depth	Sets minimum depth needed for ditch	Double	0.5'
Cut Slope	Cut slope used to daylight without ditch	Slope	-20.00:1
Create Bathtub	Option to create a bathtub with subbase	<ul style="list-style-type: none"> Yes No 	Yes
Bathtub Slope	Slope of the Subbase Bathtub	Slope	2:00:1

Parameter	Description	Type	Default
Pave 1 Depth (Referenced from Lane)	Used as a Parameter Reference to define the thickness of the Pave1 layer	Double	0.3 ft
Pave 2 Depth (Referenced from Lane)	Used as a Parameter Reference to define the thickness of the Pave2 layer	Double	0.0 ft
Base Depth (Referenced from Lane)	Used as a Parameter Reference to define the thickness of the base layer	Double	0.5 ft
Subbase Depth (Referenced from Lane)	Subbase Depth	Double	2.00'
Normal Crown Base Distance (Referenced from Shoulder)	Used as a Parameter Reference to define the bottom of base/top of subbase normal crown width	Double	5.5'
Normal Crown Slope (Referenced from Shoulder)	Used as a Parameter Reference to define the normal crown slope	Grade	-2.00%
SE Base Distance (Referenced from Shoulder)	Used as a Parameter Reference to define the bottom of base/top of subbase superelevated width	Double	5.5'
SE Base Slope (Referenced from Shoulder)	Used as a Parameter Reference to define the bottom of base/top of subbase superelevated slope	Slope	-2.00%
Inslope Extension Offset (Referenced from Shoulder)	Used as a Parameter Reference to define the inslope extension offset (safety slope)	Double	0

Parameter	Description	Type	Default
Rounded Surface Inslope (Referenced from Shoulder)	Used as a Parameter Reference to define the rounded surface inslope	Double	-0.162
Custom Point Code Suffix	Custom Suffix characters	String	_L-In
Fill Slope 1	Slope to be used if distance to surface is less than Fill Height 1	Slope	6.00:1
Fill Height 1	Compared against actual height above surface	Double	10.0'
Fill Slope 2	Slope to be used if distance to surface is less than Fill Height 2	Slope	4.00:1
Fill Height 2	Compared against actual height above surface	Double	20.0'
Fill Slope 3	Slope to be used if distance to surface is less than Fill Height 3	Slope	3.00:1
Fill Height 3	Compared against actual height above surface	Double	30.0'
Fill Slope 4	Slope to be used if distance to surface is less than Fill Height 4	Slope	2.00:1
Fill Height 4	Compared against actual height above surface	Double	40.0'
Fill Slope 5	Slope to be used if distance to surface is less than Fill Height 5	Slope	2.00:1

Parameter	Description	Type	Default
Fill Height 5	Compared against actual height above surface	Double	50.0'
Max Fill Height	Used if the distance to surface is greater than all of the Fill Height values	Double	2.00:1
Cut Slope 1	Slope to be used if distance to surface is less than Cut Height 1	Slope	5:00:1
Cut Height 1	Compared against actual height above surface	Double	5.0'
Cut Slope 2	Slope to be used if distance to surface is less than Cut Height 2	Slope	4.00:1
Cut Height 2	Compared against actual height above surface	Double	10.0'
Cut Slope 3	Slope to be used if distance to surface is less than Cut Height 3	Slope	3.00:1
Cut Height 3	Compared against actual height above surface	Double	15.0'
Cut Slope 4	Slope to be used if distance to surface is less than Cut Height 4	Slope	2.00:1
Cut Height 4	Compared against actual height above surface	Double	20.0'
Cut Slope 5	Slope to be used if distance to surface is less than Cut Height 5	Slope	2.00:1

Parameter	Description	Type	Default
Cut Height 5	Compared against actual height above surface	Double	25.0'
Max Cut Slope	Used if the distance to surface is greater than all of the Cut Height values	Slope	2.00:1

TARGET PARAMETERS

Parameter	Description
Daylight Target Surface	Used for daylighting and calculations for which Fill or Cut slope should be utilized.
Foreslope Slope control profile	Used for defining the foreslope slope using a control profile target.
Foreslope Width Offset	Used for defining the foreslope width using an offset target.
Foreslope Width control profile	Used for defining the foreslope width using a control profile target.
Ditch Width Offset	Used for defining the ditch width using an offset target.
Ditch Width control profile	Used for defining the ditch width using a control profile target.
Ditch Slope Elevation	Used for defining the ditch slope width using an elevation target.
Ditch Slope control profile	Used for defining the ditch slope using a control profile target.
Use Bathtub control profile	Used for defining the Bathtub switch (off/on) using a control profile target.

Parameter	Description
Sub Build Options control profile	Used for defining the Subbase switch (with/without) using a control profile.
Forced Catch Offset	Used for defining an offset in either cut or fill.
Forced Cut Offset	Used for defining an offset and forcing a cut slope.
Forced Fill Offset	Used for defining an offset in and forcing a fill slope.
Forced Daylight Offset	Used for defining an offset and forcing a daylight slope.
End Condition Options control profile	Used for defining the end conditions using a control profile.
PESC Ditch On/Off Target	Toggle used to turn the PESC ditch option on or off.

BEHAVIOR

End condition behaviors

In a fill condition; the Subassembly iterates through each pair of Fill Height and Fill Slope values, targets the surface, and checks the height above the surface to determine if it is less than the specified fill height. If it is not less than the specified fill height, it will move on to the next Fill Height and Fill Slope pair. Once a calculated height is found that is less than the fill height, the Fill Slope specified for that fill height is applied.

In a cut condition; the Subassembly draws the initial slope link at the specified Foreslope using the specified Foreslope Width. The Foreslope and Foreslope Width can also be adjusted with an offset target or a control profile. Next, it draws the ditch link at the specified Ditch Slope using the specified Ditch Width. The ditch width and elevation can be adjusted with width, elevation or control profile targets. Last, it iterates through each pair of Cut Height and Cut Slope values, targets the surface and checks the height below the surface to determine if it is less than the specified cut height. If it is not less than the specified cut height, it will move on to the next Cut Height and Cut Slope pair. Once a calculated height is found that is less than the cut height, the Cut Slope specified for that cut height is applied.

Select Subassembly build options

Daylight; creates end condition daylight points and links.

Daylight with Subbase; attaches the subbase to the end condition daylight to create a subbase shape that matches the subbase on the lane and shoulder bottom of base.

Parameter references assigned from the adjacent MDT Shoulder and MDT Lane Subassembly will automatically size the Subbase shape to the bottom of base on the shoulder Subassembly and Subbase depth of the lane Subassembly. The bottom link of the Subbase shape will use the same slope as the Normal Crown Slope except when in a high side superelevation condition where it will use the SE Base Slope parameter reference.

Create Bathtub

Yes; when the Foreslope Width is less than the distance between the intersection point of the Foreslope and bottom of subbase slope, casts out the final cut slope from the attachment point to the Foreslope Width and then slopes inward with the Bathtub Slope until it intersects the bottom of the subbase.

No; casts out the final cut slope from the attachment point to the intersection point of the Foreslope and bottom of subbase slope.

LAYOUT MODE OPERATION

Layout mode shows a graphic of the daylight slope calculations performed for both cut and fill. The display of the Subassembly will update to reflect the slope and other dimensional parameter values as they are set.

POINT, LINK, AND SHAPE CODES

The following table lists the point, link and shape components for this Subassembly. Point and link codes for this Subassembly that do not have codes assigned are not included in this table.

Code	Description	Type	Default
[P1] Hinge Point (Attachment point)	Bottom of base/top of subbase	String	
[P2] Edge of Subbase	Edge of Subbase	String	LabelElevationOffset, Edge_Subbase

Code	Description	Type	Default
[P3] Inside Ditch point	Inside ditch point	String	LabelElevationOffset, Daylight_Foreslope
[P4] Outside Dich point	Outside ditch point (flowline)	String	LabelElevationOffset, Daylight_DitchBtm
[P5] Daylight	Point tying into existing ground (construction limit)	String	Daylight
[P6] Subbase and Inslope intersect point	Intersection point of subbase and edge	String	LabelElevationOffset, Edge_SubbaseBot
[P7] Subbase Bathtub slope intersect point	Intersection of bottom of subbase and bathtub slope	String	SubbaseBot
[P8] Inside bottom of Subbase	Bottom of subbase along the edge	String	SubbaseBot
[P9] Inside bottom of Base	Inside bottom of base point	String	
[P10] Daylight Cut	Cut point tying into existing ground (construction limit)	String	LabelElevationOffset, Daylight_Cut
[P11] Daylight Fill	Fill point tying into existing ground (construction limit)	String	LabelElevationOffset, Daylight_Fill
[L1] Inslope Extension	Inslope extension link	String	Top, Subbase
[L2] Foreslope (Subbase Inslope)	Foreslope link	String	LabelSlope, Top, Subbase
[L3] Ditch Bottom	Bottom of Ditch link	String	LabelSlope, Top, Datum, Ditch

Code	Description	Type	Default
[L4] Daylight Fill	Fill slope link	String	LabelSlope, Top, Datum, Daylight_Fill
[L7] Subbase bottom (Datum)	Bottom of subbase link	String	SubbaseBot
[L8] Bathtub Slope (Datum)	Bathtub link	String	SubbaseBot
[L9] Daylight Cut	Cut slope link	String	LabelSlope, Top, Datum, Daylight_Cut
[S1] Subbase	Subbase layer	String	Subbase

CODING DIAGRAM

DAYLIGHT CUT - FORESLOPE WIDTH > SUBBASE INSLOPE WIDTH

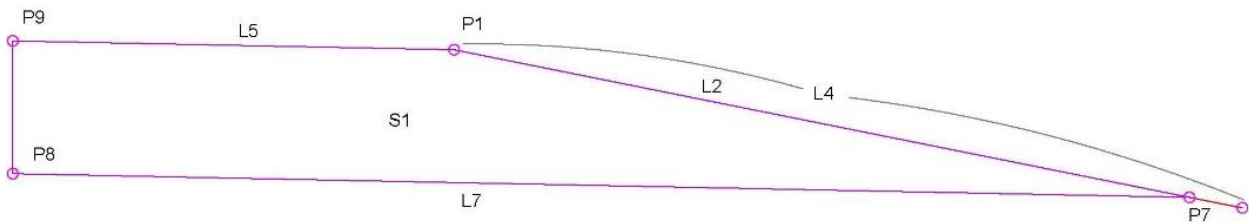

DAYLIGHT CUT - USE BATHTUB FORESLOPE WIDTH < SUBBASE INSLOPE WIDTH

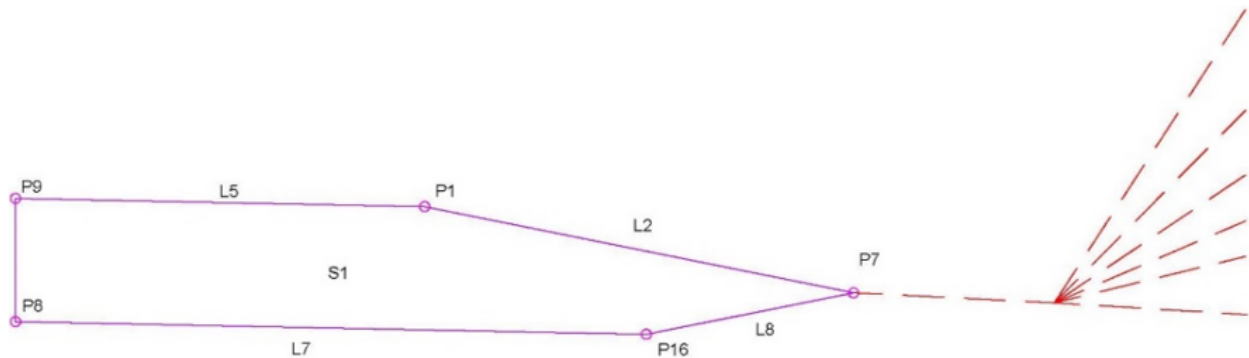

DAYLIGHT CUT - FORESLOPE WIDTH < SUBBASE INSLOPE WIDTH

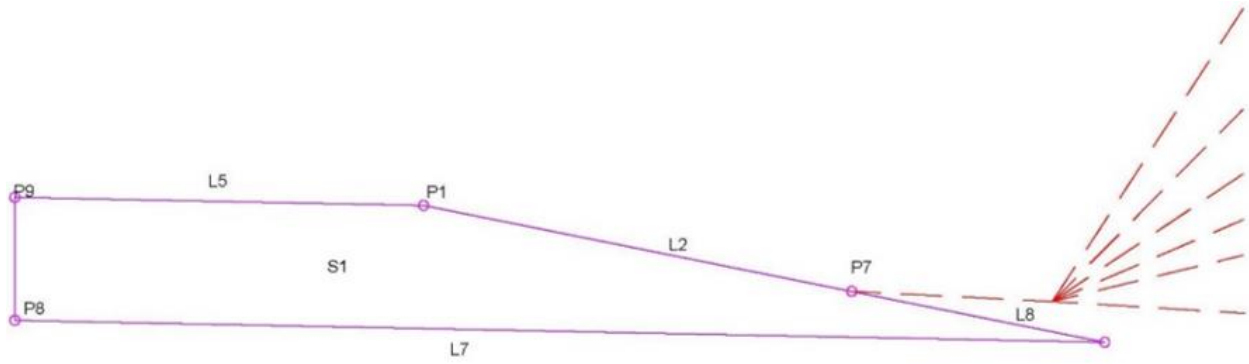

DAYLIGHT FILL

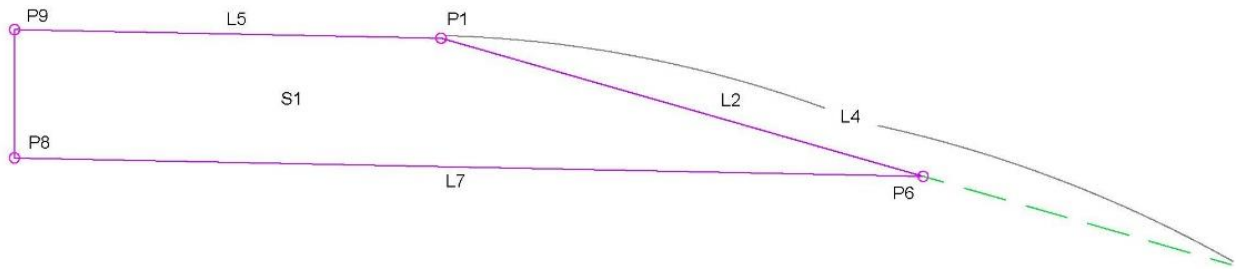

DAYLIGHT FILL WITH EXTENDED HINGE POINT < SUBBASE INSLOPE WIDTH

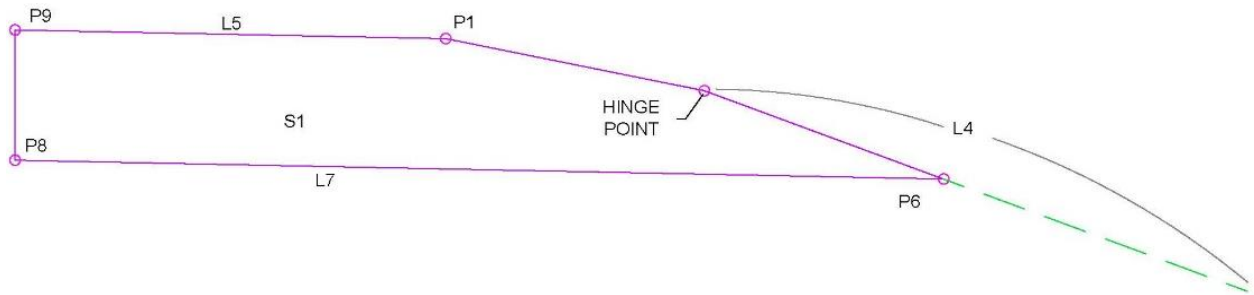

DAYLIGHT FILL WITH EXTENDED HINGE POINT > SUBBASE INSLOPE WIDTH

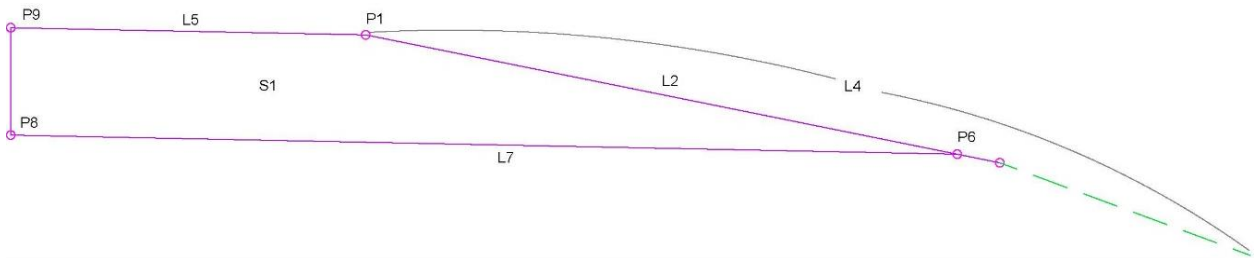

SUPERELEVATION

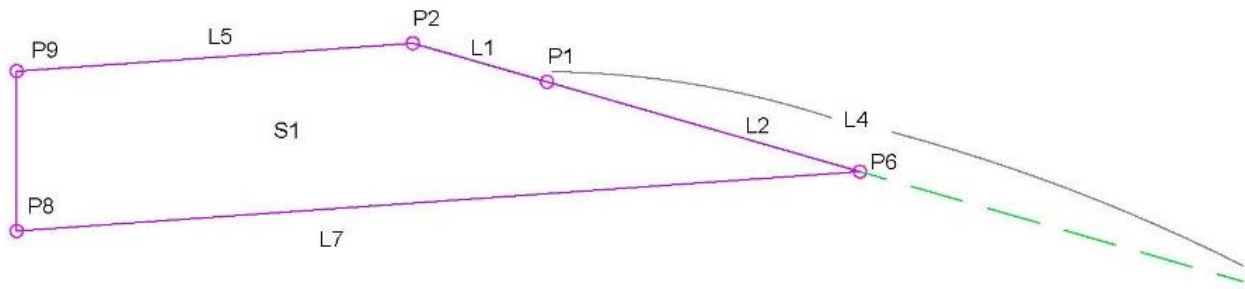

MDT CURB & GUTTER

HOW THIS SUBASSEMBLY CAN BE USED:

The MDT Curb & Gutter Subassembly can represent the following curb types: Standard, ADA Ramp, ADA Landing, Approach Laydown, Valley Gutter, Pin Down and 4" curb. This subassembly considers multiple geometric parameters that the user can change in the assembly properties, including the curb height, width, slopes, and depths.

LINKS

This subassembly creates Berm, Gutter, Face of Curb, Top of Curb, Base, Subbase and Bottom of Subbase link codes.

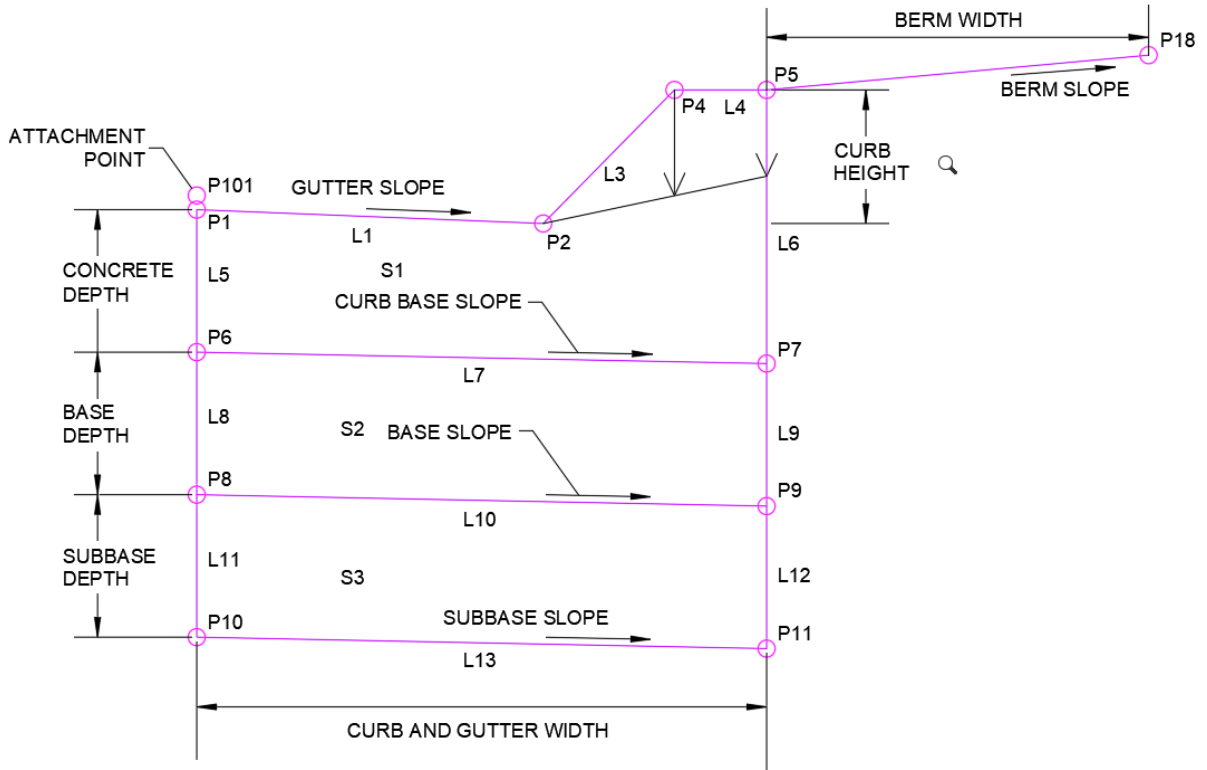

ATTACHMENT

There are two attachment point options denoted as P101 in the diagrams:

Front of Gutter:

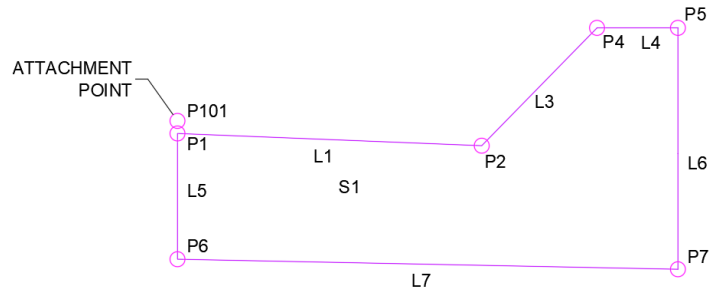

Top Back of Curb:

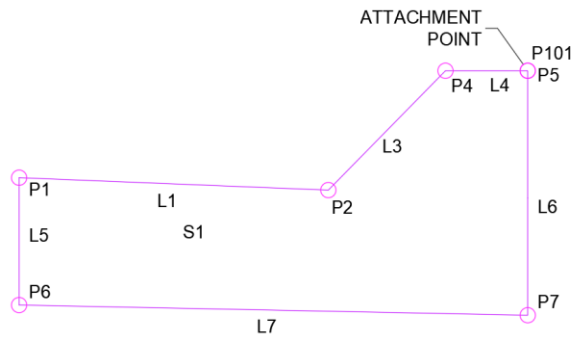

INPUT PARAMETERS

Display Name	Description	Type	Default
Side	Specifies which side to place the Subassembly.	Left / Right	Right
Point Code Location Suffix	Adds a suffix to point codes.	None/Right/	Automatic

Display Name	Description	Type	Default
		Left/Automatic/ Custom Code	
Attachment Point	Defines where to attach the curb.	Front Gutter/ Back Curb	Front Gutter
Curb Type	Defines the different curb types.	Standard/ADA Ramp/ADA Landing/ Approach Laydown/ Valley Gutter/ Pindown Curb/4" Curb	Standard
Base Depth (Referenced from Lane)	Defines the depth of base material.	Double	0.75'
Base Slope (Referenced from Lane)	Defines the slope of base material.	Grade	-2.00%
Subbase Depth (Referenced from Lane)	Defines the depth of subbase material.	Double	0.75'
Subbase Slope (Referenced from Lane)	Defines the slope of subbase material.	Grade	-2.00%
Gutter Slope Override	Overrides the defined grade of the link connecting the flange point to flowline point.	Grade	0.00%
Curb Base Slope Override	Overrides the defined slope of the base material.	Grade	0.00%
Curb Width Override	Overrides the defined width of the curb.	Double	0'

Display Name	Description	Type	Default
Gutter Width Override	Overrides the defined width of the gutter.	Double	0'
Curb Height Override	Overrides the defined height of the curb.	Double	0'
Concrete Depth Override	Overrides the defined depth of the concrete.	Double	0'
Lane Slope Override for Pindown and 4 inch Curb	Overrides the defined slope of the lane for the pindown and 4" curb to follow.	Grade	0.00%
Berm Width	Defines the width of the berm behind the curb	Double	3'
Berm Slope	Defines the slope of the berm behind the curb.	Grade	2.00%
Pavement Lip Height	Defines the height of the pavement at the front of the gutter.	Double	0'
Custom Point Code Suffix	Custom Suffix characters	String	_L-In
[P101] Attachment Point on Pavement	Front of gutter or back of curb	String	
[P1] Front of Gutter	Point defining the front of gutter.	String	LabelElevation Offset, Curb_Front_Gut ter
[P2] Flowline of Gutter	Point defining the low point of the gutter.	String	LabelElevation Offset, Curb_Flowline_ Gutter

Display Name	Description	Type	Default
[P3] Face of Curb	Point defining the face of the curb.	String	Curb_Face
[P4] Top Front of Curb	Point defining the top front of the curb.	String	Curb_Top_Front
[P5] Top Back of Curb	Point defining the top back of the curb.	String	LabelElevationOffset, Curb_Top_Back
[P6] Top Front of Base	Point defining the top front of the base material.	String	Curb_Top_Front_Base
[P7] Top Back of Base	Point defining the top back of the base material.	String	Curb_Top_Back_Base
[P8] Top Front of Subbase	Point defining the top front of the subbase material.	String	Curb_Top_Front_Subbase
[P9] Top Back of Subbase	Point defining the top back of the subbase material.	String	Curb_Top_Back_Subbase
[P10] Bottom Front of Subbase	Point defining the bottom front of the subbase material.	String	Curb_Bot_Front_Subbase
[P11] Bottom Back of Subbase	Point defining the bottom back of the subbase material.	String	Curb_Bot_Back_Subbase
[P12] Berm	Point defining the berm width.	String	Curb_Berm
[L1] Gutter	Link defining the gutter	String	Curb_Gutter, Top
[L2] Gutter	Link defining the gutter	String	Curb_Gutter, Top

Display Name	Description	Type	Default
[L3] Face of Curb	Link defining the face of the curb.	String	Curb_Face, Top
[L4] Top of Curb	Link defining the top of the curb.	String	Curb_Top, Top
[L7] Base	Link defining the top of the base material.	String	Curb_Base
[L10] Subbase	Link defining the top of the subbase material.	String	Curb_Subbase
[L13] Bottom of Subbase	Link defining the bottom of the subbase material.	String	Curb_Subbase_Bot, Datum
[L14] Berm	Link defining the top of the berm.	String	Curb_Berm, Top, Datum
[S1] Curb	Shape defining the curb.	String	Curb
[S2] Base	Shape defining the base material.	String	Curb_Base
[S3] Subbase	Shape defining the subbase material.	String	Curb_Subbase

TARGET PARAMETERS

Display Name	Description	Type
Berm Offset	Used to override the berm width using an offset target.	Offset
Berm Elevation	Used for defining the berm elevation using an elevation target.	Elevation

Display Name	Description	Type
Top Back of Curb Offset	Used to override the top back of curb using an offset target.	Offset
Top Back of Curb Elevation	Used for defining the top back of curb elevation using an elevation target.	Elevation
Front of Gutter Offset	Used to override the front of the gutter using an offset target.	Offset
Front of Gutter Elevation	Used for defining the front of the gutter elevation using an elevation target.	Elevation
Flowline Offset	Used to override the flowline of the gutter using an offset target.	Offset
Flowline Elevation	Used for defining the flowline elevation using an elevation target.	Elevation
Existing Surface for Slope Override	Used to override the existing surface for the slope.	Surface
Curb Height Control Profile	Used for defining the curb height using a control profile.	Elevation

BEHAVIOR

The MDT Curb & Gutter subassembly is built off a baseline alignment and profile, with the attachment point being the front of the gutter or the back of the curb. The subassembly provides standard curb types that can be selected: Standard, ADA Ramp, ADA Landing, Approach Laydown, Valley Gutter, Pindown Curb and 4" Curb. Based on these parameters, the curb geometry is built.

Various override parameters can be set by the user, including curb width, curb height, gutter slope, gutter width, concrete depth, base & subbase depths, and base & subbase slopes.

The gutter slope and base slopes can be controlled independently. The gutter slope is controlled by the curb type selected or the Gutter Slope Override parameter. The base

and subbase slopes are controlled by Base Slope and Subbase Slope or referenced from the Lane. See the target parameters for more options to control slopes.

The Standard Curb has options for a berm. The berm width and slope can be controlled by parameters or by using targets.

The subassembly also contains a parameter to control the vertical offset between the edge of pavement and the front of gutter. This is controlled using the Pavement Lip Height parameter.

LAYOUT MODE OPERATION

Layout mode shows a graphic of the curb type selected and will update to reflect any adjusted parameters that are set.

CODING DIAGRAMS

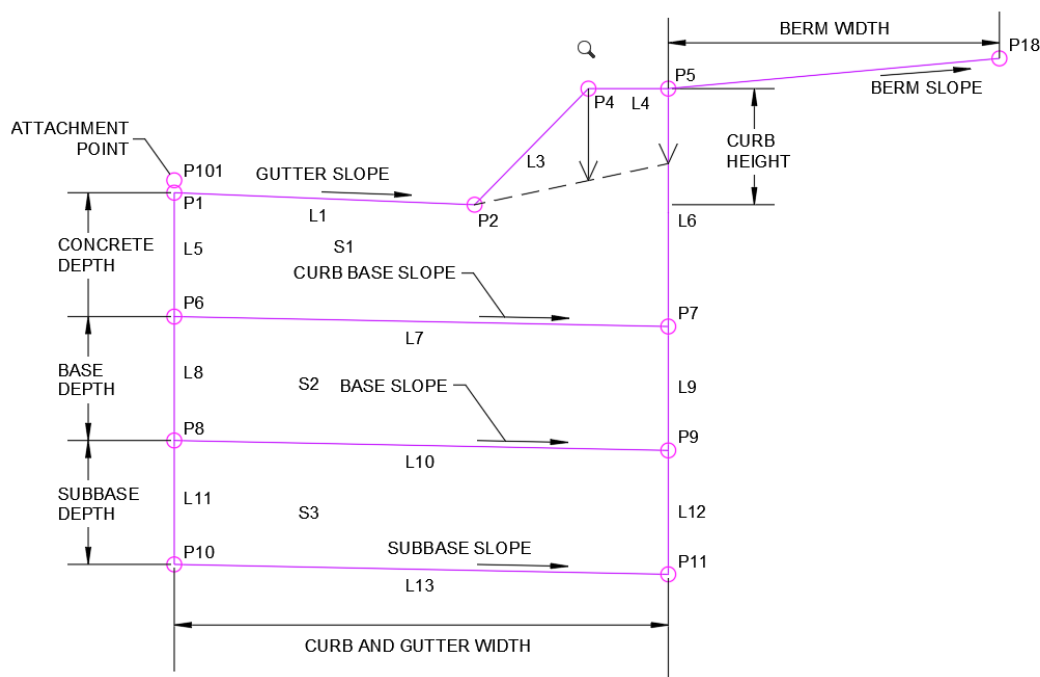

Figure 1: Standard Curb & Gutter Diagram

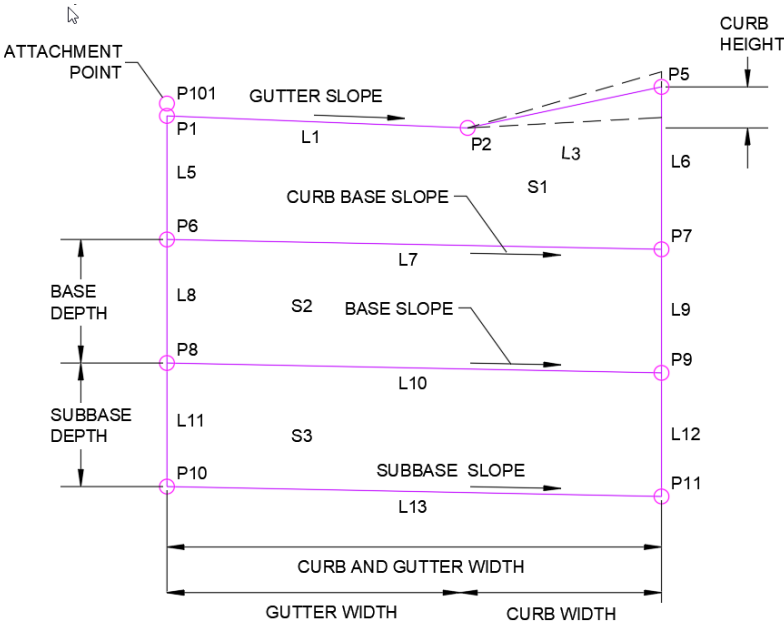

Figure 2: ADA Ramp, ADA Landing, and Approach Laydown Curbs Diagram
(varying Top of Curb Slopes)

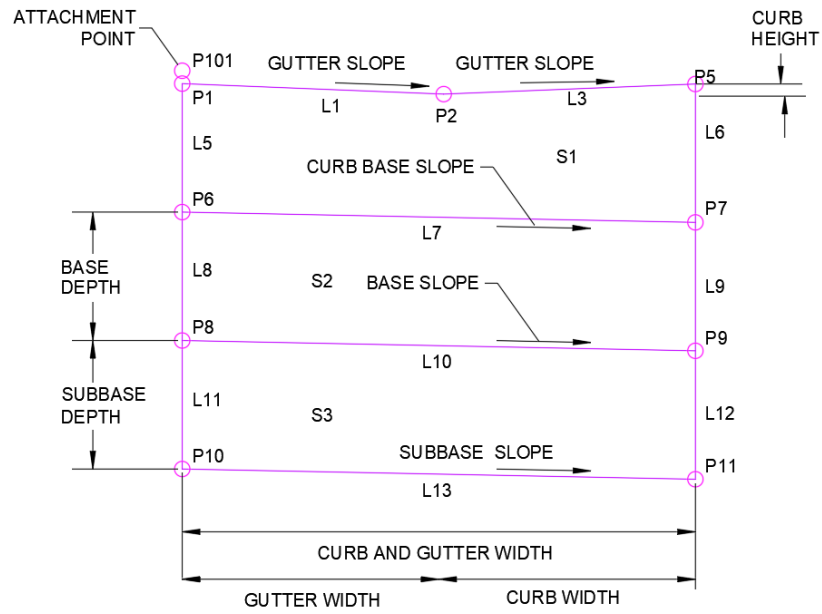

Figure 3: Valley Gutter Diagram

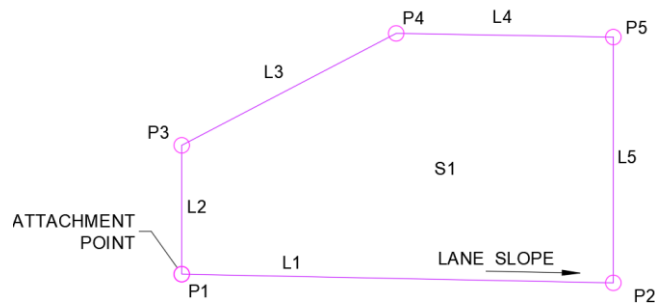

Figure 4: Pindown Curb Diagram

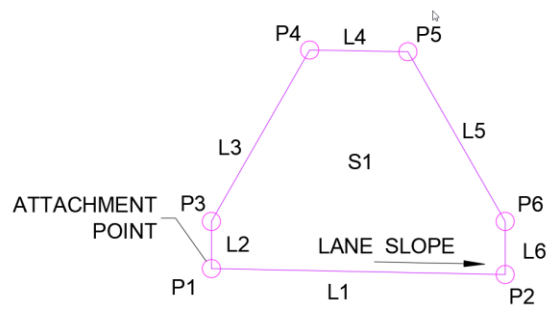

Figure 5: 4" Curb Diagram

MDT SIDEWALK

HOW THIS SUBASSEMBLY CAN BE USED:

The MDT Sidewalk Subassembly can be used for modeling lengths of sidewalk. The Subassembly consists of a sidewalk section, a base section, and a subbase section.

LINKS

The Subassembly creates Top, Datum, Sidewalk, Sidewalk_Base, and Sidewalk_Subbase and Sidewalk_SubbaseBot links. Shapes are created for Sidewalk, Sidewalk_Base, and Sidewalk_Subbase.

ATTACHMENT

The attachment point is the top inside point of the sidewalk.

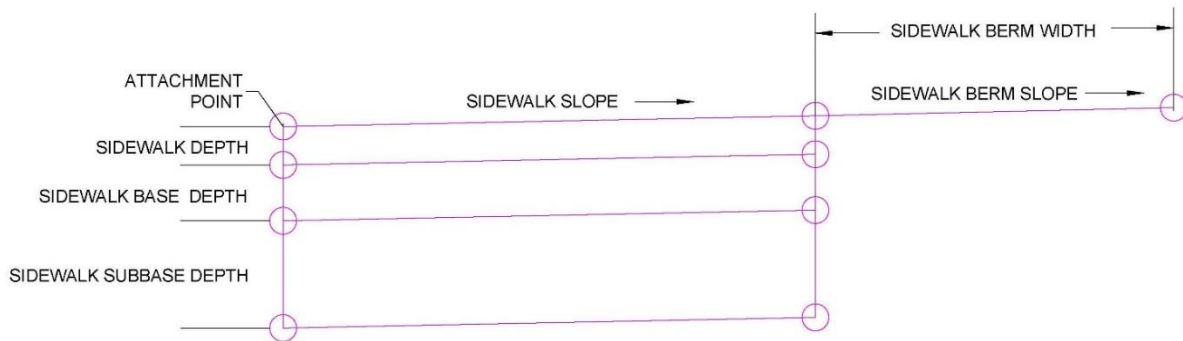

INPUT PARAMETERS

Note: All dimensions are in feet unless otherwise noted.

Parameter	Description	Type	Default
Side	Specifies which side to place the Subassembly	Left / Right	Right
Point Code Location Suffix	Adds a suffix to point codes.	None/Right Left/Automatic/ CustomCode	Automatic

Sidewalk Width	Specifies the width of the sidewalk	Double, positive	5.000'
Sidewalk Slope	Specifies the slope of the sidewalk	Grade	-1.50%
Sidewalk Depth	Specifies the depth of the sidewalk	Double, positive	0.500'
Sidewalk Base Depth	Specifies the depth of the base under the sidewalk	Double, positive	1.000'
Sidewalk Subbase Depth	Specifies the depth of the subbase under the base	Double, positive	1.000'
Sidewalk Berm Width	Specifies the berm width	Double, positive	2'
Sidewalk Berm Slope	Specifies the berm slope	Grade	3.00%
Custom Point Code Suffix	Custom Suffix characters	String	_L-In
[P1] Sidewalk (inside)	Inside of sidewalk on finish grade	String	LabelElevationOffset, Sidewalk_In
[P2] Sidewalk (outside)	Outside of sidewalk on finish grade	String	LabelElevationOffset, Sidewalk_Out
[P3] Base of Sidewalk (inside)	Inside of sidewalk on base grade	String	Sidewalk_Base_In
[P4] Base of Sidewalk (outside)	Outside of sidewalk on base grade	String	Sidewalk_Base_Out
[P5] Subbase of Sidewalk (inside)	Inside of sidewalk on subbase grade	String	Sidewalk_Subbase_In

[P6] Subbase of Sidewalk (outside)	Outside of sidewalk on subbase grade	String	Sidewalk_Subbase_Out
[P7] Subbase Bottom of Sidewalk (inside)	Inside of sidewalk on subbase bottom grade	String	Sidewalk_SubbaseBot_In
[P8] Subbase Bottom of Sidewalk (outside)	Outside of sidewalk on subbase bottom grade	String	Sidewalk_SubbaseBot_Out
[P9] Sidewalk Berm (outside)	Outside of sidewalk berm	String	Sidewalk_Berm_Out
[L1] Top of Sidewalk	Top of sidewalk	String	LabelSlope, Top, Sidewalk_Top
[L4] Top of Sidewalk Base	Top of sidewalk base	String	Sidewalk_Base
[L7] Top of Sidewalk Subbase	Top of sidewalk subbase	String	Sidewalk_Subbase
[L10] Bottom of Sidewalk Subbase	Bottom of sidewalk subbase	String	Sidewalk_SubbaseBot, Datum
[L11] Sidewalk Berm	Top of sidewalk berm	String	Sidewalk_Berm, Top, Datum
[S1] Sidewalk	Sidewalk	String	Sidewalk
[S2] Base_Sidewalk	Base of sidewalk	String	Sidewalk_Base
[S3] Subbase_Sidewalk	Subbase of sidewalk	String	Sidewalk_Subbase

TARGET PARAMETERS

Parameter	Description
Outside Edge of Sidewalk	Horizontal location of outside edge of sidewalk
Elevation of Outside Edge	Vertical elevation of outside edge of sidewalk
Sidewalk Berm Offset	Horizontal location of outside of sidewalk berm
Sidewalk Berm Elevation	Vertical elevation of outside of sidewalk berm

OUTPUT PARAMETERS

There are no output parameters.

BEHAVIOR

Starting at the attachment point, a sidewalk shape is inserted using the parameters set for sidewalk width, sidewalk slope, and sidewalk depth. A parallel base layer and parallel sub base layer are inserted using the given depths, and the sidewalk slope parameter. All point, link, and shape codes can be renamed to aid in the creation of corridor surfaces or in annotating section views.

LAYOUT MODE OPERATION

Layout mode will show graphical changes as parameter values are set.

CODING DIAGRAM

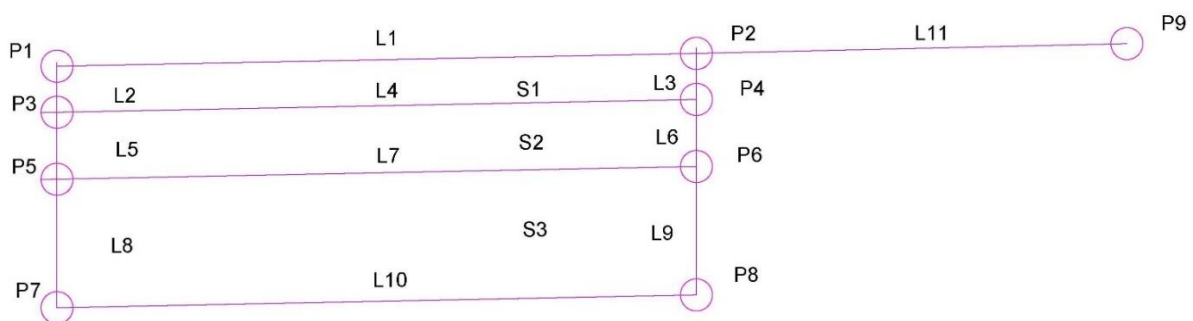

MDT PARAMETER REFERENCES

HOW THIS SUBASSEMBLY CAN BE USED:

The MDT Parameter Reference Subassembly is used to input parameter values and use the output as parameter reference inputs for adjacent Subassemblies in a single direction.

The intended use of this Subassembly is to allow an individual parameter value to be consumed by different parameters in many locations of an Assembly. For example, if all lane Subassemblies in an Assembly are to have the same lane width, the lane width can be set once in an MDT Parameter Reference Subassembly and used as the input for all the lane width parameters in the adjacent Subassemblies. When the lane width value is updated in the parameter reference, all the consuming parameters will change to the updated value. This can increase efficiency by automating changes to Assemblies.

LINKS

No links are created.

ATTACHMENT

The attachment point is at the baseline of the assembly, or at the inner most point of adjacent Subassemblies that will use the parameters as reference.

INPUT PARAMETERS

Display name	Description	Type	Default
Pave1 depth	Sets Pave1 depth value	Double, positive	0.000'
Pave2 depth	Sets Pave2 depth value	Double, positive	0.000'
Base depth	Sets Base depth value	Double, positive	0.000'
Subbase depth	Sets Subbase depth value	Double, positive	0.000'

Lane 1 width	Sets Lane 1 width	Double, positive	0.000'
Lane 2 width	Sets Lane 2 width	Double, positive	0.000'
Lane 3 width	Sets Lane 3 width	Double, positive	0.000'
Lane 4 width	Sets Lane 4 width	Double, positive	0.000'
Lane 1 slope	Sets Lane 1 slope	Grade	0.00%
Lane 2 slope	Sets Lane 2 slope	Grade	0.00%
Lane 3 slope	Sets Lane 3 slope	Grade	0.00%
Lane 4 slope	Sets Lane 4 slope	Grade	0.00%
Integer 1	Sets Integer 1	Integer	0
Integer 2	Sets Integer 2	Integer	0
Integer 3	Sets Integer 3	Integer	0
Integer 4	Sets Integer 4	Integer	0

TARGET PARAMETERS

Display name	Description	Type
Pave1 depth from profile	May be used to override the Pave1 depth to the elevation of a profile. The following object types can be used as targets for specifying the elevation: profiles, 3D polylines, feature lines, or survey figures.	Elevation
Pave2 depth from profile	May be used to override the Pave2 depth to the elevation of a profile. The following object types can be used as targets for specifying the elevation:	Elevation

	profiles, 3D polylines, feature lines, or survey figures.	
Base depth from profile	May be used to override the Base depth to the elevation of a profile. The following object types can be used as targets for specifying the elevation: profiles, 3D polylines, feature lines, or survey figures.	Elevation
Subbase depth from profile	May be used to override the Subbase depth to the elevation of a profile. The following object types can be used as targets for specifying the elevation: profiles, 3D polylines, feature lines, or survey figures.	Elevation
Lane 1 width from profile	May be used to override the normal lane width and tie the outer edge of the travel lane to the elevation of a profile. The following object types can be used as targets for specifying the elevation: profiles, 3D polylines, feature lines, or survey figures.	Elevation
Lane 2 width from profile	May be used to override the normal lane width and tie the outer edge of the travel lane to the elevation of a profile. The following object types can be used as targets for specifying the elevation: profiles, 3D polylines, feature lines, or survey figures.	Elevation
Lane 3 width from profile	May be used to override the normal lane width and tie the outer edge of the travel lane to the elevation of a profile. The following object types can be used as targets for specifying the elevation: profiles, 3D polylines, feature lines, or survey figures.	Elevation
Lane 4 width from profile	May be used to override the normal lane width and tie the outer edge of the travel lane to the elevation of a profile. The following object types can be used as targets for specifying the elevation: profiles, 3D polylines, feature lines, or survey figures.	Elevation
Lane 1 slope from profile	May be used to override the normal lane slope and tie the outer edge of the travel lane to the elevation of a profile. The following object types can be used as targets for specifying the elevation: profiles, 3D polylines, feature lines, or survey figures.	Elevation

Lane 2 slope from profile	May be used to override the normal lane slope and tie the outer edge of the travel lane to the elevation of a profile. The following object types can be used as targets for specifying the elevation: profiles, 3D polylines, feature lines, or survey figures.	Elevation
Lane 3 slope from profile	May be used to override the normal lane slope and tie the outer edge of the travel lane to the elevation of a profile. The following object types can be used as targets for specifying the elevation: profiles, 3D polylines, feature lines, or survey figures.	Elevation
Lane 4 slope from profile	May be used to override the normal lane slope and tie the outer edge of the travel lane to the elevation of a profile. The following object types can be used as targets for specifying the elevation: profiles, 3D polylines, feature lines, or survey figures.	Elevation
Integer 1 from profile	May be used to override the Integer 1 to the elevation of a profile. The following object types can be used as targets for specifying the elevation: profiles, 3D polylines, feature lines, or survey figures.	Elevation
Integer 2 from profile	May be used to override the Integer 1 to the elevation of a profile. The following object types can be used as targets for specifying the elevation: profiles, 3D polylines, feature lines, or survey figures.	Elevation
Integer 3 from profile	May be used to override the Integer 1 to the elevation of a profile. The following object types can be used as targets for specifying the elevation: profiles, 3D polylines, feature lines, or survey figures.	Elevation
Integer 4 from profile	May be used to override the Integer 1 to the elevation of a profile. The following object types can be used as targets for specifying the elevation: profiles, 3D polylines, feature lines, or survey figures.	Elevation

OUTPUT PARAMETERS

Display name	Description	Type
Pave1 depth value	Pave1 depth value to be used for parameter references by adjacent Subassemblies	Double, positive
Pave2 depth value	Pave2 depth value to be used for parameter references by adjacent Subassemblies	Double, positive
Base depth value	Base depth value to be used for parameter references by adjacent Subassemblies	Double, positive
Subbase depth	Subbase depth value to be used for parameter references by adjacent Subassemblies	Double, positive
Lane 1 width value	Width value to be used for parameter references by adjacent Subassemblies	Double, positive
Lane 2 width value	Width value to be used for parameter references by adjacent Subassemblies	Double, positive
Lane 3 width value	Width value to be used for parameter references by adjacent Subassemblies	Double, positive
Lane 4 width value	Width value to be used for parameter references by adjacent Subassemblies	Double, positive
Lane 1 slope value	Slope value to be used for parameter references by adjacent Subassemblies	Grade
Lane 2 slope value	Slope value to be used for parameter references by adjacent Subassemblies	Grade
Lane 3 slope value	Slope value to be used for parameter references by adjacent Subassemblies	Grade
Lane 4 slope value	Slope value to be used for parameter references by adjacent Subassemblies	Grade
Integer 1 value	Integer value to be used for parameter references by adjacent Subassemblies	Integer

Integer 2 value	Integer value to be used for parameter references by adjacent Subassemblies	Integer
Integer 3 value	Integer value to be used for parameter references by adjacent Subassemblies	Integer
Integer 4 value	Integer value to be used for parameter references by adjacent Subassemblies	Integer

BEHAVIOR

The Subassembly acts as a “container for reference parameter values”. The parameter values can be referenced by adjacent Subassemblies lying in an outward direction from the MDT Parameter Reference Subassembly attachment point. Subassemblies lying inward from the MDT Parameter Reference Subassembly attachment point cannot reference these parameter values. The Subassembly has a “side” parameter, so individual left and right MDT Parameter Reference Subassemblies must be used for each side of an Assembly.

LAYOUT MODE OPERATION

The Subassembly displays an attachment point and an arrow pointing in the direction that the parameter values can be referenced. No parameter values are visible in the drawing.

POINT, LINK, AND SHAPE CODES

There are no point, link, or shape codes for this Subassembly. The attachment point is uncoded.

CODING DIAGRAM

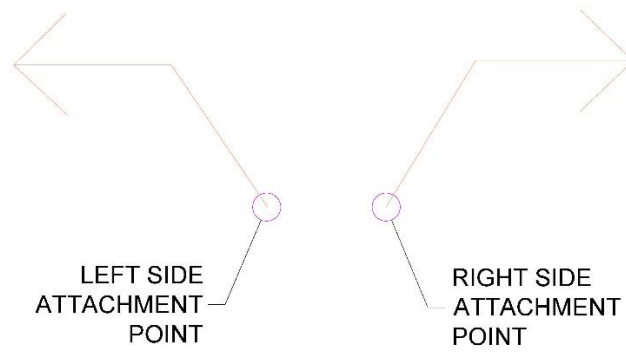

Attach subassemblies outward from the MDT Parameter Reference subassembly.

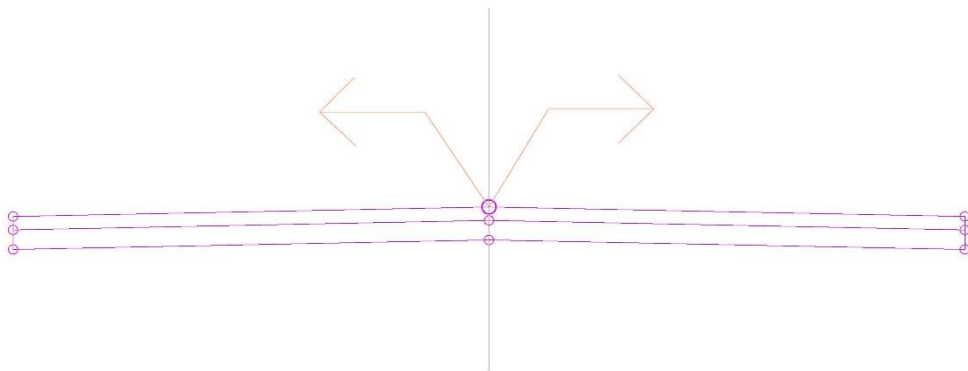

MDT OFFSET ON SURFACE LINK

HOW THIS SUBASSEMBLY CAN BE USED:

This subassembly may be used to acquire an offset point on a surface from the subassembly's attachment point. A link between these points can also be created. This subassembly may acquire an additional slope from the attachment point to a defined point at a specified offset on a surface as an output.

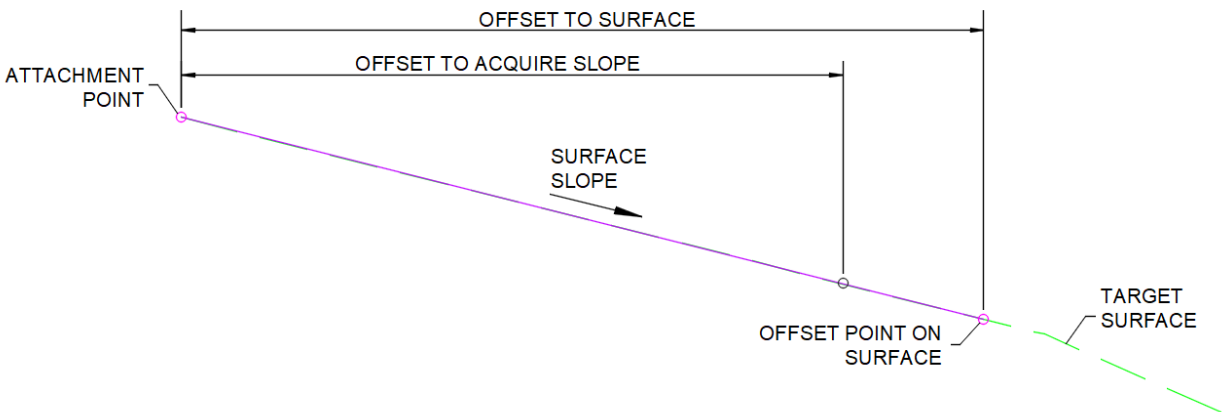

LINKS

This subassembly has a single link that connects the attachment point to an offset point on a target surface.

ATTACHMENT

The attachment point is the inside point of the offset.

INPUT PARAMETERS

Display Name	Description	Type	Default
Display Name	Description	Type	Default
Side	Specifies which side to place the Subassembly.	Left / Right	Right
Point Code Location Suffix	Adds a suffix to point codes.	None/Right Left/Automatic/	None

		CustomCode	
Offset to Surface	Offset distance to surface	Double, positive	12'
Offset to Acquire Slope	Offset distance to Acquire Slope	Double, positive	12'
Omit Link	Option to Omit the Link	Yes/No	No
Custom Point Code Suffix	Custom Suffix characters	String	_L-In
[P1] Attachment point	Attachment point	String	
[P2] Offset point	Distance to offset point	String	Top, Daylight
[L1] Offset link	Offset surface	String	Top

TARGET PARAMETERS

Display Name	Description	Type
Surface	Surface	Surface
Offset	Offset	Offset
Offset Control Profile	Offset Control Profile	Elevation
Slope Offset	Slope Offset	Offset
Slope Offset Control Profile	Slope Offset Control Profile	Elevation

OUTPUT PARAMETERS

Display Name	Description	Type
Slope value	Slope value	Slope

BEHAVIOR

This subassembly requires a surface target and an input **Offset** parameter value or defined offset targets. The subassembly creates a point on the attachment point and a point on the offset surface location. A link can be created or omitted by setting the **Omit Link** parameter to Yes, to create the Link or No to omit creating the Link.

The subassembly has a separate **Offset to Acquire Slope** parameter that may be set to a different distance than the **Offset** parameter. The slope between the attachment point and a point on the surface at the Offset to Acquire Slope offset is the value used for the **Slope value** output.

The **Offset** and **Slope Offset** can each be assigned their own horizontal offset object target or be assigned the numeric values from a control profile target.

LAYOUT MODE OPERATION

Layout mode shows the basic graphic shape of the subassembly.

CODING DIAGRAM

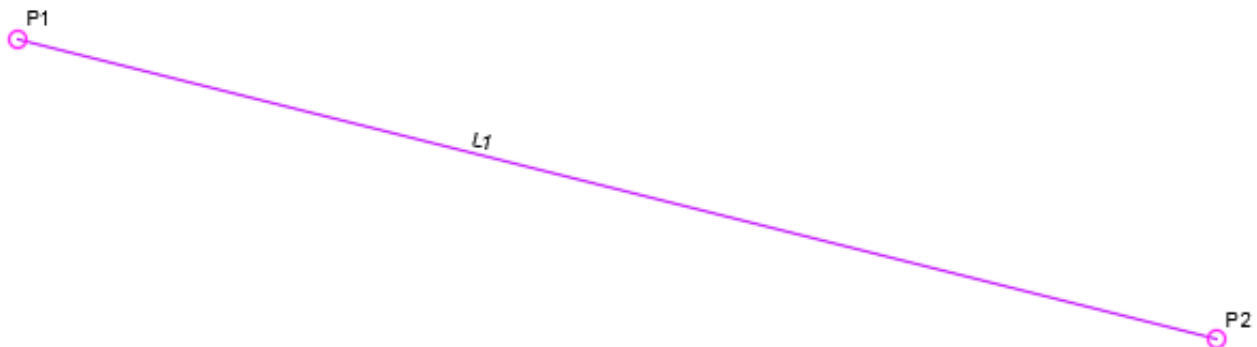

MDT SLOPE TO SURFACE LINK

HOW THIS SUBASSEMBLY CAN BE USED:

This subassembly uses cut and fill slope parameters to define a daylight point on a surface. A daylight foreslope link between the insertion point and the daylight point is created. A material thickness value may be added to define a material shape along the bottom of the link.

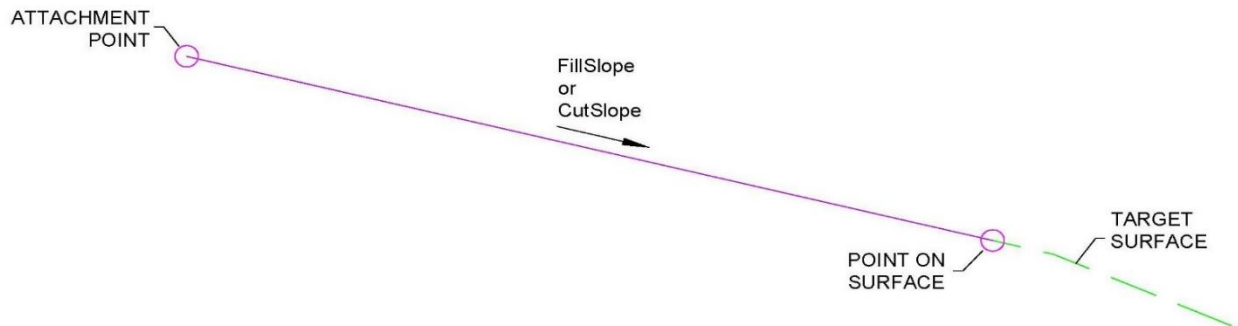

LINKS

This subassembly has a single link that connects the attachment point to the daylight point on a target surface.

ATTACHMENT

The attachment point is the inside point of the offset.

INPUT PARAMETERS

Display name	Description	Type	Default
Side	Specifies which side to place the subassembly	None/Left/Right	Right
Point Code Location Suffix	Adds a suffix to point codes.	None/Right Left/Automatic/ CustomCode	None
Cut/Fill Option	Specifies cut or fill option	Cut/Fill	Both

Cut Slope	Sets the cut slope value	Slope	5.00:1
Fill Slope	Sets the fill slope value	Slope	5.00:1
Number of Cut Intercepts (1 to 4)	Number of cut intercepts (1 to 4)	Integer	1
Number of Fill Intercepts (1 to 4)	Number of fill intercepts (1 to 4)	Integer	1
Material Thickness	Assign a material thickness to the link	Double, positive	0
Custom Point Code Suffix	Custom Suffix characters	String	_L-In
[P1] Attachment point	Attachment point	String	Attachment point
[P2] Daylight Fill Point	Daylight point if fill	String	Daylight_Fill, Daylight
[P3] Daylight Cut Point	Daylight point if cut	String	Daylight_Cut, Daylight
[P4] Material Bottom Inside	Inside point on the bottom of the material layer	String	Material_Bottom_In
[P5] Material Bottom Outside	Outside point on the bottom of the material layer	String	Material_Bottom_Out
[L1] Daylight Fill	Daylight fill surface	String	Daylight_Fill, Top, Datum

TARGET PARAMETERS

Display Name	Description	Type
--------------	-------------	------

Daylight Surface	Surface	Surface
Cut Slope Control Profile	Control Profile	Elevation
Fill Slope Control Profile	Control Profile	Elevation
Cut or Fill Switch (Both 0, +Fill, -Cut)	Switch	Elevation

OUTPUT PARAMETERS

Display Name	Description	Type	Default
Final Slope Value	Final slope value	Slope	2.00:1
Daylight Offset Value	Daylight offset value	Double	0
Daylight Elevation value	Daylight elevation value	Double	0

BEHAVIOR

This subassembly requires a surface target and an input **Cut Slope** and **Fill Slope** parameter value or defined Control Profile target slope values. The subassembly creates a point on the attachment point and a point on the surface based on the slope parameters provided and the cut or fill condition at the insertion point location. A link connects these two points.

The subassembly has an option to determine how many times the target surface will be intercepted before a final daylight point is created. There is a separate Intercept parameter for cut and for fill. The number of surface intercepts in a cut condition is defined with the **Number of Cut Intercepts (1 to 4)** parameter, and the number of surface intercepts in a fill condition is defined with the **Number of Fill Intercepts (1 to 4)** parameter. If the subassembly is set to solve only a fill condition and doesn't intersect the surface target the subassembly will default back to a cut condition.

LAYOUT MODE OPERATION

Layout mode shows the basic graphic shape of the subassembly.

CODING DIAGRAM

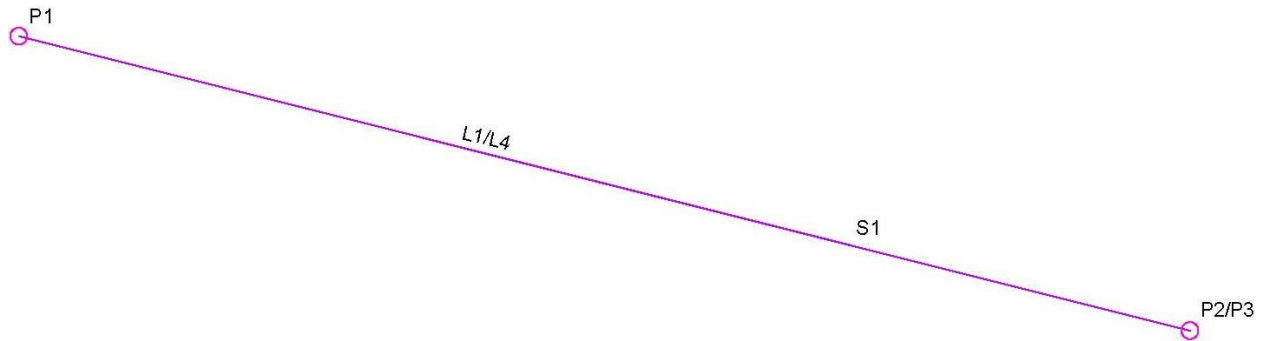

MDT CONNECT SURFACE SLOPE LINKS

HOW THIS SUBASSEMBLY CAN BE USED:

This subassembly may be used to create a preliminary or setup surface derived from targeting and sampling an existing surface at offset locations on the right and or left side or may be used to attach other subassemblies on as a final corridor. A sample offset can be created on the left, right or both sides, targeting a surface. A “Slope Sampling” offset can be created as a width from the offset point in either direction to acquire the slope between the offset and sample offset point. Links may be created between each of these points and extended along the slope in either direction. If the links are extended inward (one on the left and one on the right), they may be set to extend to their intersection point.

A link may also be created as an offset right and left to intercept each slope link and also create a third link. This could be used for developing a setup target surface to use in median, intersection, roundabout, and other corridor development where a modified surface target is required to show conditions interpreted from an existing ground surface or design surface.

Each offset may be a horizontal or control profile target.

Each slope sample has two outputs, outward and inward slope value.

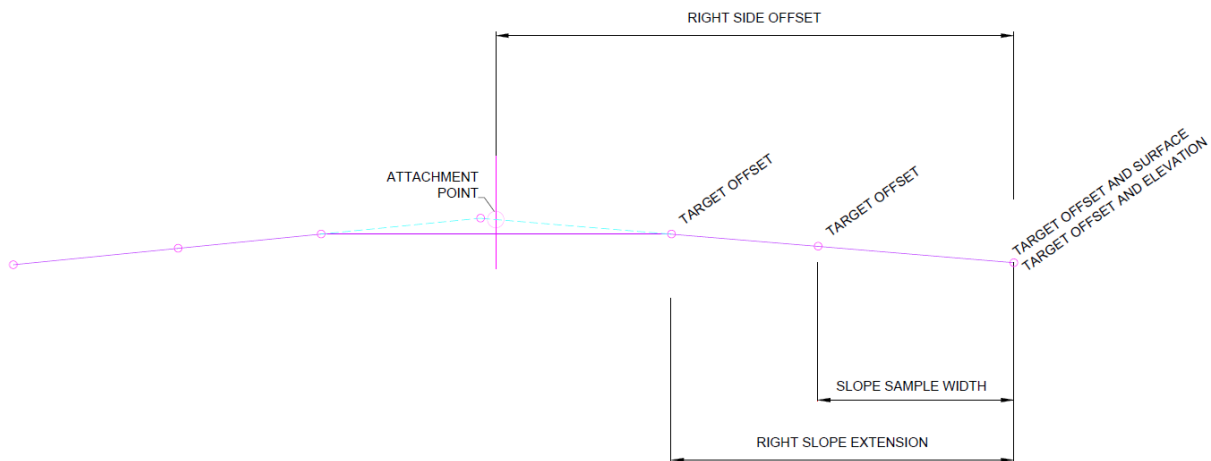

LINKS

This Subassembly creates up to five links as the top surface.

ATTACHMENT

The attachment point is on the baseline (alignment) being used for the corridor.

INPUT PARAMETERS

Display Name	Description	Type	Default
Side	Specifies which side to place the Subassembly.	Left/Right/None	Left
Point Code Location Suffix	Adds a suffix to point codes.	None/Right Left/Automatic/ CustomCode	None
Slope Sample Width	Outer extent of the sample area	Double	0.5
Intersect Slopes	Option to intersect the left and right slopes	Yes/No	Yes
Right Slope Extension	Extended distance to the right for the new calculated slope	Double	3
Left Slope Extension	Extended distance to the left for the new calculated slope	Double	3
Left Side Offset	Total distance to the left to be sampled and extended	Double	-10
Right Side Offset	Total distance to the right to be sampled and extended	Double	10
Add Existing Top Surface Links	Adds links for constructing a surface	Yes/No	Yes
Custom Point Code Suffix	Custom Suffix characters	String	_L-In

Display Name	Description	Type	Default
[P1] Left Connect to Surface Point		String	Top
[P2] Left Extend Slope Point		String	Top
[P3] Point Intersect of Slopes		String	Top
[P4] Right Extend Slope Point		String	Top
[P5] Right Connect to Surface Point		String	Top
[L1] Left Surface Match Slope		String	Top
[L2] Left Slope from Extension to Intersect		String	Top
[L3] Right Slope from Extension to Intersect		String	Top
[L4] Right Surface Match Slope		String	Top
[L5] Slope from Left and Right Connect Points		String	Top-Exist

TARGET PARAMETERS

Display Name	Description	Type
Right Side Offset	Distance of offset to the right	Offset
Left Side Offset	Distance of offset to the left	Offset
Surface Target	Targeted surface	Surface

BEHAVIOR

This subassembly creates a preliminary or setup surface derived from targeting and sampling an existing surface at offset locations on the right and/or left side. A “Slope Sampling” offset is used to acquire the slope between the offset and sample offset point. Links are created between each of these points and extended along the slope in either direction. If the links are extended inward (one on the left and one on the right), they may be set to extend to their intersection point.

A third link can be created as a connection between the offset right and left. This could be used for developing a setup target surface to use in median, intersection, roundabout, and other corridor development where a modified surface target is required to show conditions interpreted from an existing ground surface or design surface.

LAYOUT MODE OPERATION

Layout mode shows the basic graphic shape of the subassembly.

CODING DIAGRAM

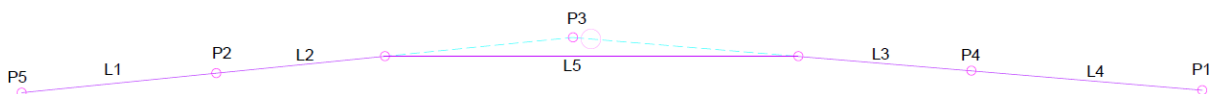

MDT CUT TABLE / MDT FILL TABLE

HOW THIS SUBASSEMBLY CAN BE USED:

These subassemblies can be used as design tools when fine tuning grading. It displays the cut slopes, cut heights, fill slopes and fill heights while doing design work. The heights and slopes can be adjusted to the design standards needed. The table displays can be turned off when done.

CUT TABLE

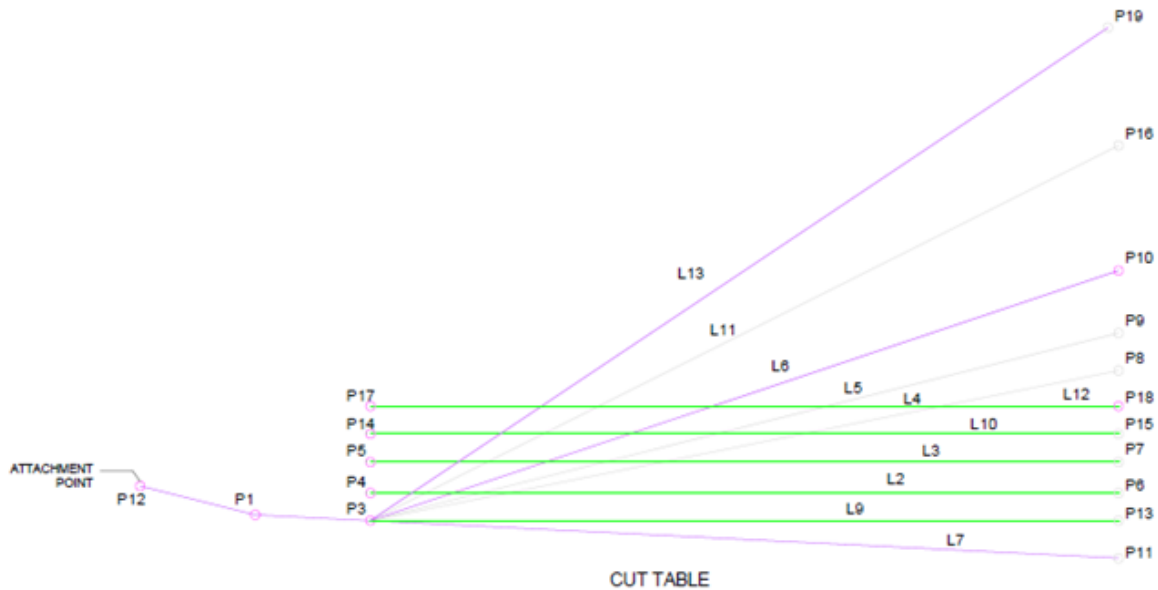

FILL TABLE

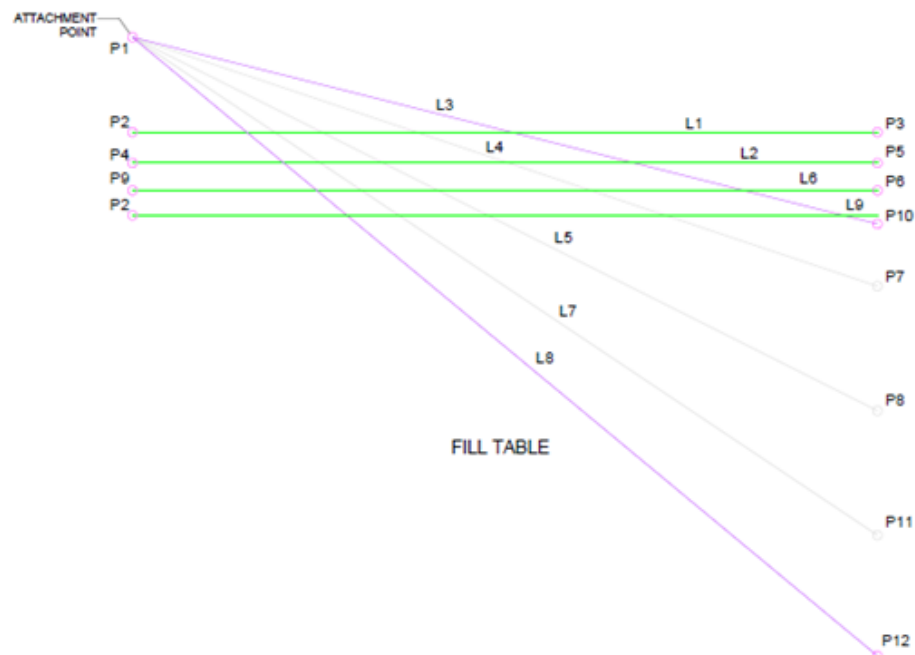

LINKS

This subassembly has links representing the various cut slopes, cut heights, fill slopes and fill heights.

ATTACHMENT

The attachment point is the hinge point (beginning of end condition).

INPUT PARAMETERS – CUT TABLE

Display name	Description	Type	Default
Side	Specifies which side to place the subassembly	None/Left/Right	Right
Table Distance	Horizontal width of table	Double	150'
Cut Slope 1	Slope to be used if distance to surface is less than Cut Height 1	Slope	5:00:1
Cut Slope 2	Slope to be used if distance to surface is less than Cut Height 2	Slope	4.00:1
Cut Slope 3	Slope to be used if distance to surface is less than Cut Height 3	Slope	3.00:1
Cut Slope 4	Slope to be used if distance to surface is less than Cut Height 4	Slope	2.00:1
Cut Slope 5	Slope to be used if distance to surface is less than Cut Height 5	Slope	1.50:1
Cut Height 2	Compared against actual height above surface	Double	5'
Cut Height 3	Compared against actual height above surface	Double	10'

Display name	Description	Type	Default
Cut Height 4	Compared against actual height above surface	Double	15'
Cut Height 5	Compared against actual height above surface	Double	20'
Ditch Width	Width of the ditch	Double	10.0'
Ditch Slope-Cut Slope Daylight	Slope along the width of the ditch and the daylight cut slope	Slope	20.00:1
Foreslope Width	Width of the Foreslope in cut condition	Double	10.0'
Foreslope Slope	Slope of Foreslope in cut condition	Slope	6.00:1
Displayed	Option to turn the display on or off	Yes/No	Yes
Origin By Mark		Yes/No	No

INPUT PARAMETERS – FILL TABLE

Display name	Description	Type	Default
Side	Specifies which side to place the subassembly	None/Left/Right	Right
Table Distance	Horizontal width of table	Double	150'
Fill Slope 1	Slope to be used if distance to surface is less than Fill Height 1	Slope	6:00:1

Display name	Description	Type	Default
Fill Slope 2	Slope to be used if distance to surface is less than Fill Height 2	Slope	4.00:1
Fill Slope 3	Slope to be used if distance to surface is less than Fill Height 3	Slope	3.00:1
Fill Slope 4	Slope to be used if distance to surface is less than Fill Height 4	Slope	2.00:1
Fill Slope 5	Slope to be used if distance to surface is less than Fill Height 5	Slope	1.50:1
Fill Height 2	Compared against actual height above surface	Double	10'
Fill Height 3	Compared against actual height above surface	Double	20'
Fill Height 4	Compared against actual height above surface	Double	30'
Fill Height 5	Compared against actual height above surface	Double	40'
Displayed	Option to turn the display on or off	Yes/No	Yes
Origin By Mark		Yes/No	No

CODING DIAGRAM

CUT TABLE

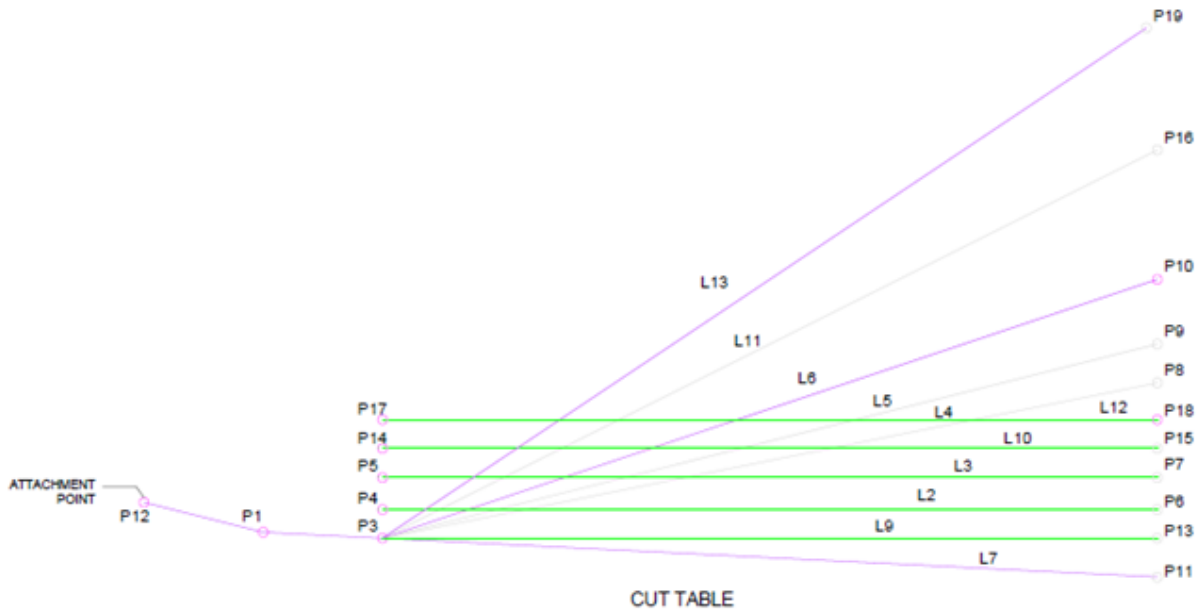

FILL TABLE

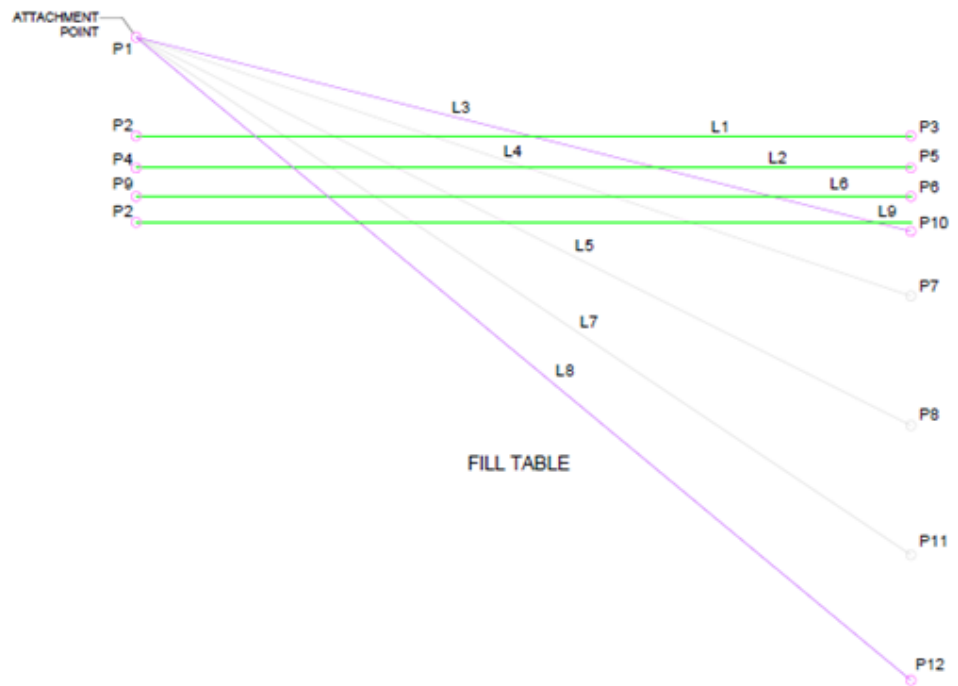

LEGACY MDT SUBASSEMBLIES

The following custom MDT Subassemblies have been previously included in the MDT Civil 3D State Kit:

- MDT Daylight (several variations)
- MDT SubBase
- MDT Curb and Gutter

Legacy MDT Subassemblies are no longer accessible on the tool palette. Summary information is included for reference when encountering instances of them in design files.

MDT DAYLIGHT

HOW THIS SUBASSEMBLY CAN BE USED:

The MDT Daylight Subassembly can be used for roadway daylighting. This Subassembly performs calculations for both cut and fill situations to choose the appropriate slope based on cut and fill heights in relation to a target surface. There are multiple variations of the MDT Daylight Subassembly on the MDT Subassemblies Tool palette. These variations all use the same base MDT Daylight Subassembly and behave as described below but have different preset parameter settings.

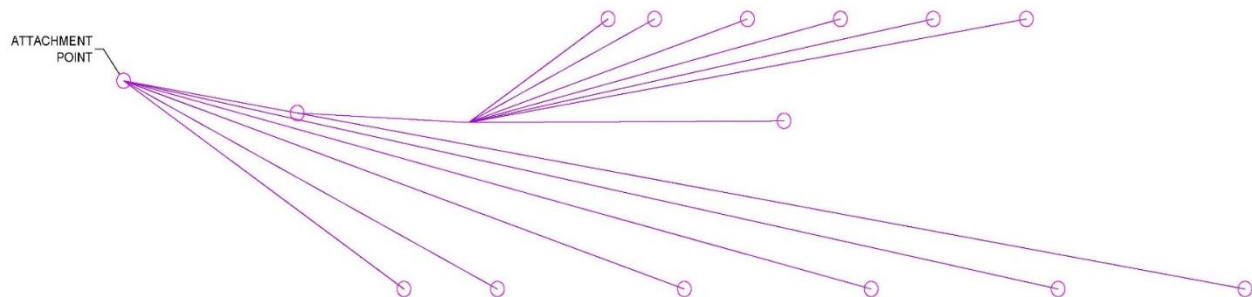

LINKS

This Subassembly creates Top, Daylight, Daylight_Cut, Daylight_Fill, Datum, Ditch, and Slope Line links.

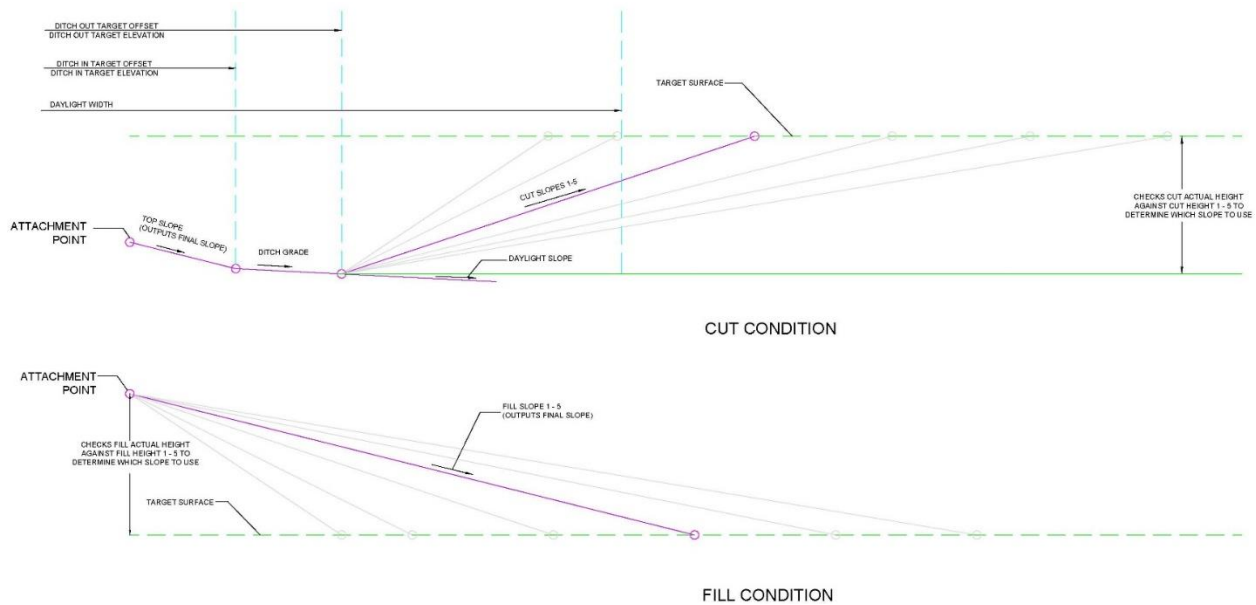

ATTACHMENT

The attachment point is as noted on the diagrams above. The attachment point is determined by the cut (top of foreslope) or fill (top of fill link) condition.

INPUT PARAMETERS

Parameter	Description	Type	Default
Side	Specifies which side to place the Subassembly	Left / Right	Right
Cut / Fill Condition	Used to override logical cut and fill conditions. Inside edge of ditch is required to be in a cut condition as there is not a berm parameter in this Subassembly	Both / Fill / Cut	Both
Top Slope	Slope used in cut condition for the initial slope link from the attachment point to the inside edge of the ditch	Slope	6.00:1
Ditch Width	Width of the ditch	Double, positive	10.000'

Ditch Grade	Grade along the width of the ditch	Grade, positive	5.00%
Daylight Slope	Slope of daylight cut condition	Slope	-50:1
Daylight Width	Width of corridor scanned for daylight cut condition	Double	50
Cut Slope 1	Slope to be used if distance to surface is less than Cut Height 1	Slope	6.00:1
Cut Height 1	Compared against actual height above surface	Double, positive	5.000'
Cut Slope 2	Slope to be used if distance to surface is less than Cut Height 2	Slope	5.00:1
Cut Height 2	Compared against actual height above surface	Double, positive	10.000'
Cut Slope 3	Slope to be used if distance to surface is less than Cut Height 3	Slope	4.00:1
Cut Height 3	Compared against actual height above surface	Double, positive	15.000'
Cut Slope 4	Slope to be used if distance to surface is less than Cut Height 4	Slope	3.00:1
Cut Height 4	Compared against actual height above surface	Double, positive	20.000'
Cut Slope 5	Slope to be used if distance to surface is less than Cut Height 5	Slope	2.00:1
Cut Height 5	Compared against actual height above surface	Double, positive	25.000'
Max Cut Slope	Used if the distance to surface is greater than all of the Cut Height values	Slope	1.50:1

Fill Slope 1	Slope to be used if distance to surface is less than Fill Height 1	Slope	6.00:1
Fill Height 1	Compared against actual height above surface	Double, positive	5.000'
Fill Slope 2	Slope to be used if distance to surface is less than Fill Height 2	Slope	5.00:1
Fill Height 2	Compared against actual height above surface	Double, positive	10.000'
Fill Slope 3	Slope to be used if distance to surface is less than Fill Height 3	Slope	4.00:1
Fill Height 3	Compared against actual height above surface	Double, positive	15.000'
Fill Slope 4	Slope to be used if distance to surface is less than Fill Height 4	Slope	3.00:1
Fill Height 4	Compared against actual height above surface	Double, positive	20.000'
Fill Slope 5	Slope to be used if distance to surface is less than Fill Height 5	Slope	2.00:1
Fill Height 5	Compared against actual height above surface	Double, positive	25.000'
Max Fill Height	Used if the distance to surface is greater than all of the Fill Height values	Double, positive	1.5:1
Foreslope Width	Width of the Foreslope in cut condition	Double, positive	10.000'

TARGET PARAMETERS

Parameter	Description
Surface Target	Used for daylighting and calculations for which Fill or Cut slope should be utilized
Foreslope Surface	Used for defining the foreslope width using a surface target.
Cut-Fill Condition Offset	Surface that is used to determine whether the current station, offset, and elevation is in a cut or a fill condition
Cut Fill Numeric Switch from Profile	Profile object used to determine if the Subassembly should use ditch logic (EL<1), automatic ditch/fill logic (EL=1), or fill logic (EL>1). Profile elevations are interpreted as switches for the three options. Automatic mode compares the subgrade shoulder point elevation to the target surface elevation at the specified offset.
Ditch In Offset	Horizontal control of the inside edge of the ditch
Ditch In Elevation	Vertical control of the inside edge of the ditch
Ditch Out Offset	Horizontal control of the outside edge of the ditch
Ditch Out Elevation	Vertical control of the outside edge of the ditch
Top Slope from Profile	Vertical control of the top slope by means of using a profile. Profile elevations are interpreted as slopes

OUTPUT PARAMETERS

Parameter	Description	Type
Foreslope Width	Used for parameter references by adjacent Subassemblies	Double, positive
Final Fill Slope / Cut Ditch In Slope	Used for parameter references by adjacent Subassemblies	Double, positive

BEHAVIOR

In a fill condition, the Subassembly iterates through each pair of Fill Height and Fill Slope values, targets the surface, and checks the height above the surface to determine if it is less than the specified fill height. If it is not less than the specified fill height, it will move on to the next Fill Height and Fill Slope pair. Once a calculated height is found that is less than the fill height, the Fill Slope specified for that fill height is applied. This calculated slope is output as the Final Fill Slope.

In a cut condition, the Subassembly draws the initial slope link at the specified Top Slope using the specified Foreslope Width. The inside and outside horizontal and vertical positioning of the ditch can be specified with polyline / feature line targets. Next, it draws the ditch link at the specified Ditch Grade using the specified Ditch Width. Next, it looks for a surface intercept using the Daylight Slope parameter and will draw the daylight link if it falls within the Daylight Width. Otherwise, it iterates through each pair of Cut Height and Cut Slope values, targets the surface and checks the height below the surface to determine if it is less than the specified cut height. If it is not less than the specified cut height, it will move on to the next Cut Height and Cut Slope pair. Once a calculated height is found that is less than the cut height, the Cut Slope specified for that cut height is applied. The Top Slope with the specified Foreslope Width is output as the Final Cut Ditch In-Slope.

The Cut / Fill Condition parameter can be set to force a cut or fill situation. The Foreslope width, Ditch width, Ditch in offset target, Ditch Out offset target, or Foreslope surface target may need to be set so the cut slope can find a daylight solution. A fill cannot be forced if the attachment point is in a cut condition, below the target surface.

LAYOUT MODE OPERATION

Layout mode shows a graphic of the daylight slope calculations performed for both cut and fill. The display of the Subassembly will update to reflect the slope and other dimensional parameter values as they are set.

POINT, LINK, AND SHAPE CODES

The following table lists the point and link components for this Subassembly. Point and link codes for this Subassembly that do not have codes assigned are not included in this table.

FILL CONDITION

Point, Link, or Shape	Code	Description
P1		Attachment Point
P14	Daylight, Daylight_Fill	Daylight point at surface
L16	Daylight, Daylight_Fill, Top, Datum	Link from attachment point to surface

CUT CONDITION

Point, Link, or Shape	Code	Description
P1		Attachment Point
P11	Ditch_In	Inside edge of ditch
P16	Ditch_Out	Outside edge of ditch
P13	Daylight, Daylight_Cut	Daylight point at surface
L13	Top, Slope_Link, Datum	Link from attachment point to inside edge of ditch
L14	Top, Ditch, Datum	Link representing the ditch bottom
L15	Top, Datum, Daylight, Daylight_Cut	Link from outside edge of ditch to the surface

CODING DIAGRAM

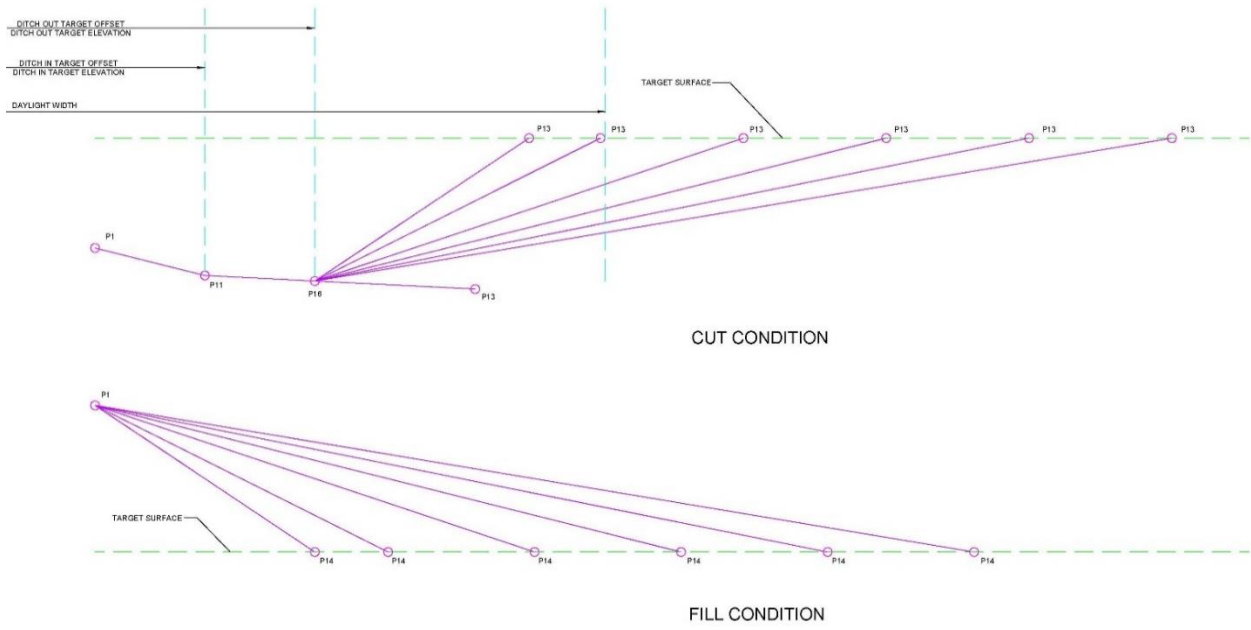

MDT SUBBASE

HOW THIS SUBASSEMBLY CAN BE USED:

The MDT SubBase Subassembly is intended for roadway subbases underneath the MDT Shoulder subassembly. The Subassembly uses parameter references of the adjacent MDT Shoulder subassembly to match with the bottom CAC width and slope of the shoulder. Input parameters control different subbase conditions such as Slope, Slope with Bathtub, Vertical, and Subbase Construction Slope.

LINKS

The Subassembly creates Top, SubBase, and Datum links. A shape is created for SubBase.

ATTACHMENT

The attachment point is the top inside point of the subbase. When used with the MDT Shoulder Subassembly, the MDT SubBase Subassembly is attached at the bottom inside point of the shoulder base course as shown in the diagram below.

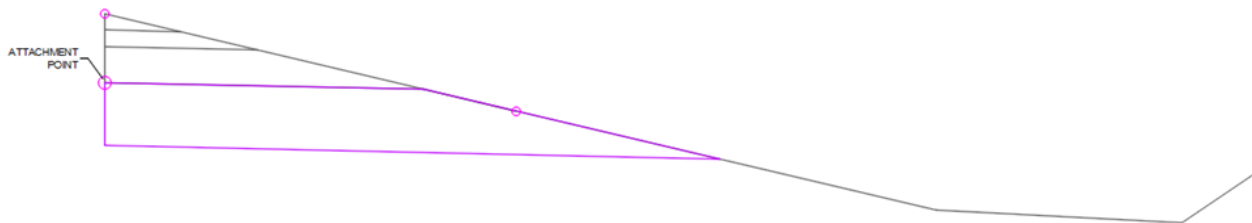

INPUT PARAMETERS

Parameter	Description	Type	Default
Side	Specifies which side to place the Subassembly.	Left / Right	Right

Outside Treatment Option	Controls the treatment options Top Slope / In slope along the Subbase.	Slope / Slope with Bathtub Vertical	Slope
Subbase Depth	Subbase Depth	Double, positive	1.000'
CAC Distance (Parameter Reference)	Used as a Parameter Reference to define the top width of the Subbase	Double, positive	5.000'
CAC Slope (Parameter Reference)	Used as a Parameter Reference to define the top of the Subbase slope	Slope	-2.00%
Daylight Final Slope (Parameter Reference)	Slope of Daylight final slope obtained from assigning parameter reference	Slope	6.00:1
Shoulder Top Slope (Parameter Reference)	Slope of Top slope of Shoulder obtained from assigning parameter reference	Slope	6.00:1
Hinge Width (Parameter Reference)	Hinge offset of Shoulder obtained from assigning parameter reference	Double, positive	10.000'
Use Superelevation	Controls how the Subassembly is set for calculating superelevation	Superelevation type selection	None
Subbase Bathtub Slope	Slope of the Subbase Bathtub Slope	Slope	3:00:1
Subbase Bathtub Offset	Controls the start point of the Subbase Bathtub Slope and offset for the Vertical point. Offset distance is measured from the Attachment point	Double, positive	0.000'
Inside Construction Slope	Toggle to display the Construction Slope	Yes / No	No

Construction Slope	Slope of the Inside Construction Slope	Slope	3:00:1
Saw Cut Depth	Controls the start point of the Inside Construction slope. Start point is along the inside vertical link and the Saw Cut Depth is measured from the top of the Subbase Shape.	Double, positive	0.500'
Include GeoFabric	Toggle to display the GeoFabric link	Yes / No	No
[P7] EPS base point code	User control for base point code	String	
[P14] Subbase inside point code	User control for Subbase inside point code	String	ETW_Sub
[P15] Hinge Point point code	User control for Hinge Point point code	String	EPS_Sub
[P16] Subbase in-slope point code	User control for Subbase in slope point code	String	Sub_Out
[P17] Subbase Bathtub in-slope point code	User control for Subbase Bathtub in-slope point code	String	Sub_Out
[P18] GeoFabric inside point code	User control for GeoFabric inside point code	String	
[P19] GeoFabric outer point code	User control for Geofabric outer point code	String	Geo_Out
[P20] Construction Slope inside point code	User control for Construction Slope inside point code	String	
[P21] Construction Slope outer point code	User control for Construction Slope outer point code	String	

[L20] CAC link code	User control for CAC link code	String	
[L21] Construction Slope link code	User control for Construction Slope link code	String	
[L22] Subbase link code	User control for Subbase link code	String	
[L23] Subbase in-slope link code	User control for Subbase in-slope link code	String	
[L24] Subbase Bathtub link code	User control for Subbase bathtub link code	String	Datum
[L25] GeoFabric link code	User control for GeoFabric link code	String	Geo_Fab
[S4] Subbase shape code	User control for Subbase shape code	String	SubBase

TARGET PARAMETERS

Parameter	Description
Bathtub Surface Target	Target intersect surface
Hinge Point Offset	Horizontal control of the Hinge Point
Subbase Bathtub Offset	Distance from the attachment point to the Hinge Point

OUTPUT PARAMETERS

There are no output parameters.

BEHAVIOR

The parameter references from the adjacent MDT Shoulder or LaneSuperelevationAOR Subassembly will automatically stretch the Subbase shape to the bottom of shoulder and daylight Subassemblies, as parameters values are assigned. The bottom link of the Subbase shape will use the same slope as the CAC Slope parameter reference so that they are parallel to one another.

The outside treatment options control what happens opposite of the attachment point. **Slope** casts out the final top slope from the attachment point, through the Hinge point, where it intersects the projected bottom link of the subbase based on the final daylight top/in slope parameter. **Slope with bathtub** casts out the final top slope from the attachment point, through the Hinge point to the Subbase Slope Offset distance based on the final daylight top/in slope parameter, then slopes inward with the Subbase Bathtub Slope until it intersects the bottom of the subbase. **Vertical** option allows for a vertical condition from the bottom outside Base point on the shoulder Subassembly to the bottom of subbase.

For all conditions, the **Inside Construction Slope** option allows for specifying a Saw Cut Depth from the inside top corner of the Subbase Shape, sloping towards the Attachment point at the Construction Slope until it intersects the bottom of the subbase.

LAYOUT MODE OPERATION

Layout mode shows the basic graphic shape of the subbase; however, the majority of parameter settings do not reflect visually in the drawing. Only items such as Side, Outside Treatment options, and Inside Construction Slope appear in the layout view.

OUTSIDE TREATMENT OPTION – SLOPE

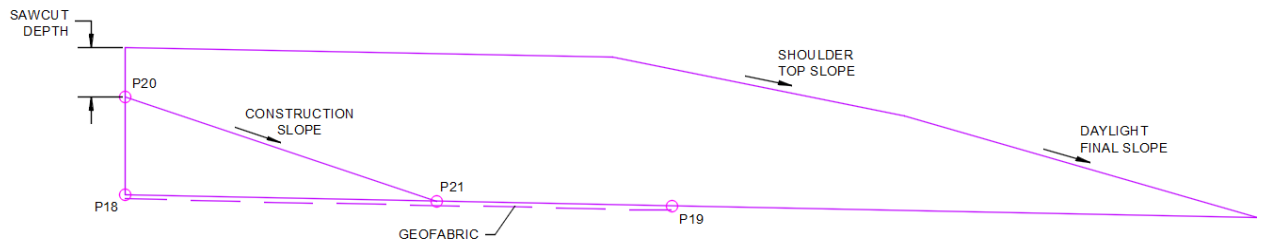
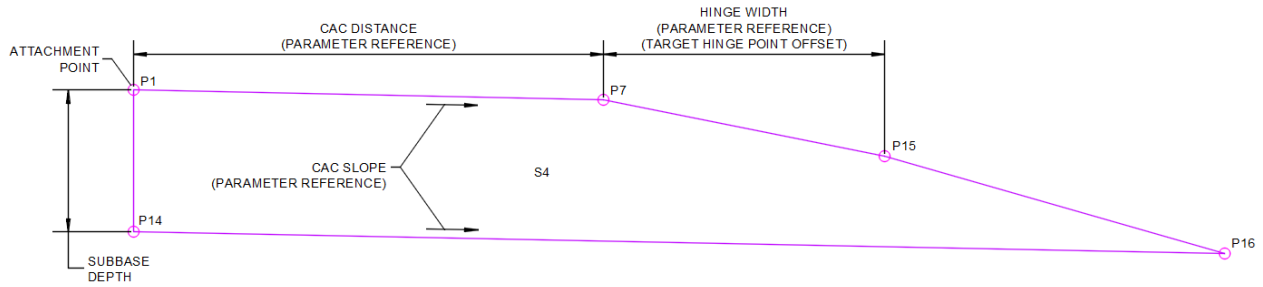

OUTSIDE TREATMENT OPTION – SLOPE WITH BATHTUB

Bathtub offset parameter

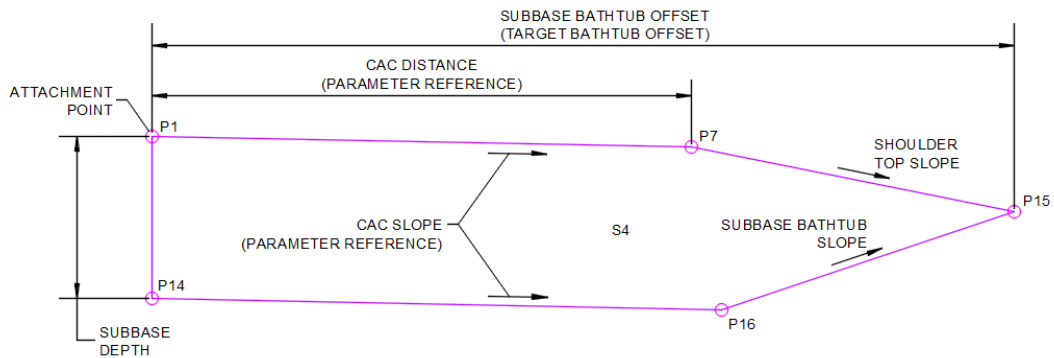

Bathtub with target offset

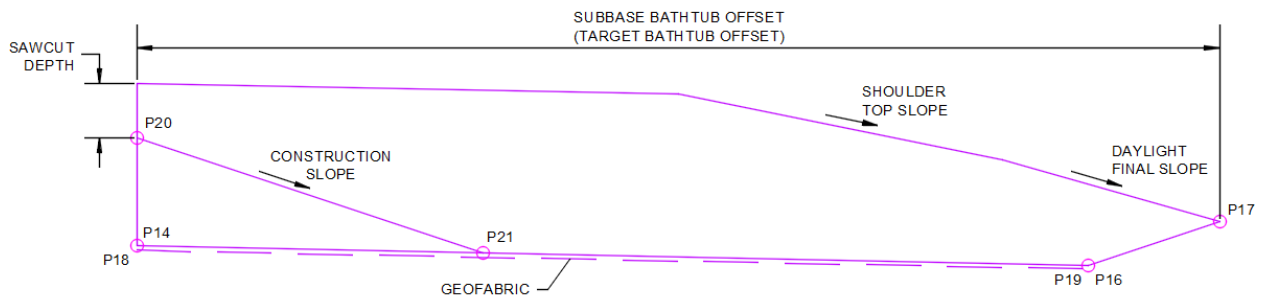

Bathtub with target surface

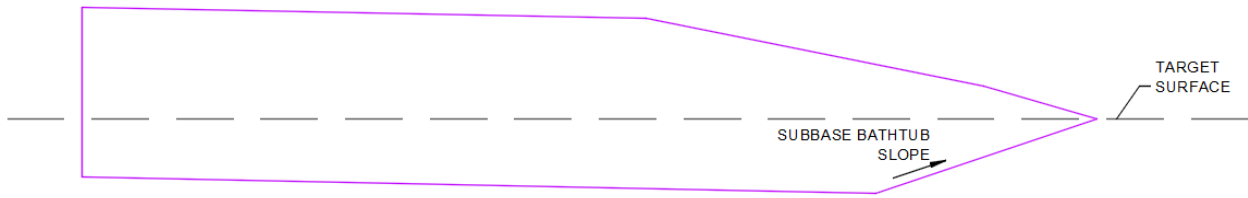

OUTSIDE TREATMENT OPTION – VERTICAL

Vertical with hinge width

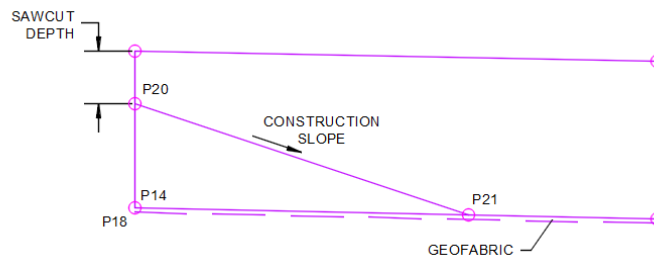
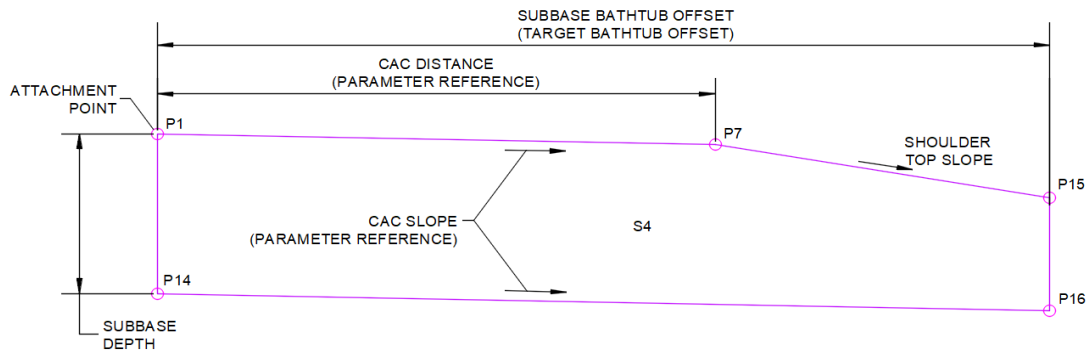

MDT CURB AND GUTTER

HOW THIS SUBASSEMBLY CAN BE USED:

The MDT Curb and Gutter Subassembly can be used in situations where a curb is present on the inside or outside edge of the roadway. This subassembly considers multiple geometric parameters that the user can change in the assembly properties, including the curb height, width, slopes, and depths.

LINKS

This subassembly creates Top, Curb, Base, SubBase, and Datum link codes.

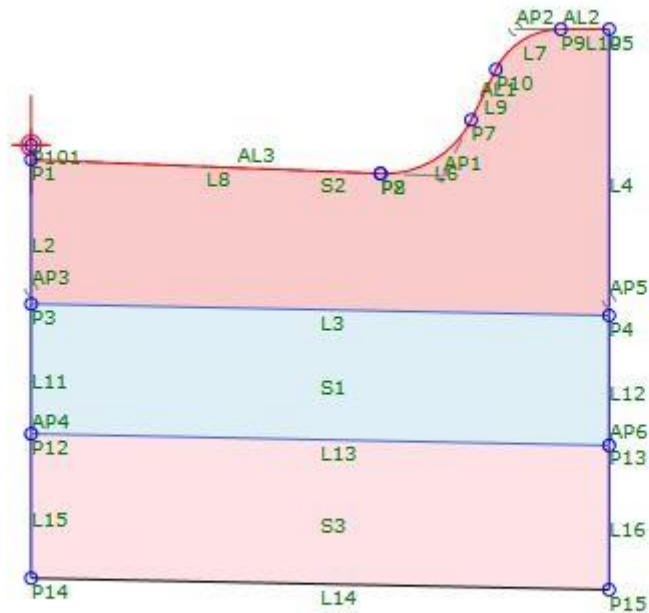

ATTACHMENT

The attachment point is located at the edge of pavement, notated as P101 in the diagram above.

INPUT PARAMETERS

Display Name	Description	Type	Default
Side	Specifies which side to place the Subassembly.	Left / Right	Right
Curb Height	Defines the curb height, measured vertically from the flowline to top back of curb.	Double	0.5
Gutter Slope	Defines the grade of the link connecting the flange point to flowline point.	Grade	-4.00%
Draw Arcs	Specifies whether to draw fillets/arcs or not.	Yes/No	Yes
Base Slope	Defines the grade of the base, subbase, and datum links.	Grade	-2.00%
Pave1 Depth	Defines the pavement depth as an origin for base depth.	Double	0.3
Base Depth	Defines the depth of the base course.	Double	0.5
Subbase Depth	Defines the depth of the subbase.	Double	0.5
Curb Width	Defines the width of the curb, measured horizontally from the flange point to back of curb line.	Double	2
Front Gutter Offset	Defines the vertical offset between front of gutter and edge of pavement.	Double	0

TARGET PARAMETERS

Display Name	Description	Type
Curb Elevation	Allows for a profile control to define the top back of curb height	Elevation

BEHAVIOR

The MDT Curb and Gutter subassembly is built off a baseline alignment and profile, with the attachment point being the flange of the curb (P1). Various parameters can be set by the user, including curb width, height, pavement depth, base & subbase depths, and base & gutter slopes. The top back elevation of curb can also be targeted, using a profile elevation.

Based on these parameters, the curb geometry is built. Users can change the design mode, to determine whether fillet arcs will be included or not. The curb will not solve correctly when the Curb Width parameter is set to anything less than 1', so the curb width should always be set greater than 1'.

The gutter slope and base slopes can be controlled independently. The gutter slope is controlled by the Gutter Slope parameter. The subbase and datum slopes will always be parallel to the base slope and are controlled by the Base Slope parameter.

The subassembly also contains a parameter to control the vertical offset between the edge of pavement and flange point. This is controlled using the Front Gutter Offset parameter.

LAYOUT MODE OPERATION

When the curb height is set below 0.167', the subassembly will go into cut-curb mode, and fillet arcs will not build. Therefore, when using a laydown curb, set the "Draw Arcs" parameter to "No". The minimum curb height for a laydown curb is 0.06'.

CODING DIAGRAM

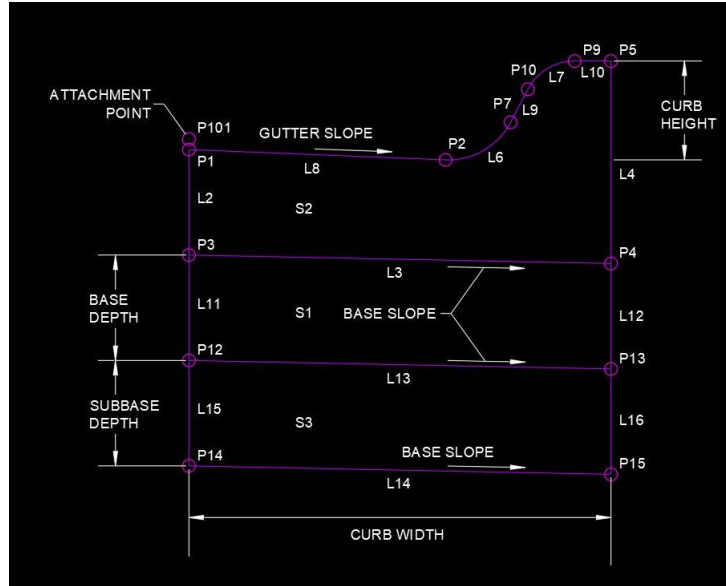

Figure 1: Standard Curb & Gutter Diagram

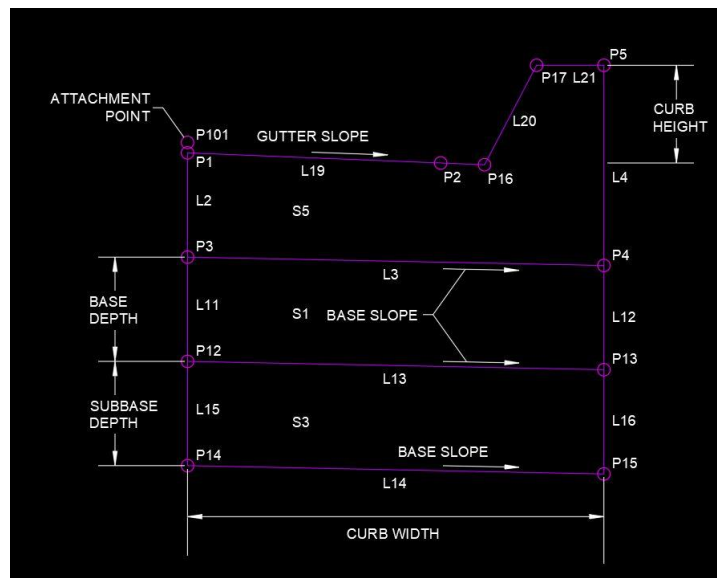

Figure 2: Curb without Fillet Arcs Diagram

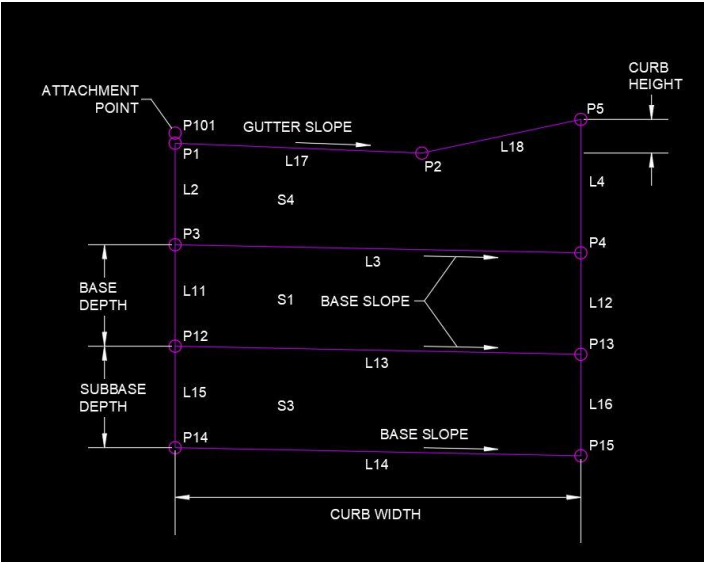

Figure 3: Curb in Laydown Mode Diagram

MDT ASSEMBLIES

The following custom MDT Assemblies are included in the MDT Civil 3D 2024 State Kit:

- MDT Rural 2 Lane
- MDT Rural 4 Lane
- MDT Rural Divided
- MDT Urban 2 Lane - Sidewalk
- MDT Ramp
- MDT Widening
- MDT Ditch Block

MDT SUBASSEMBLIES TOOL PALETTE

MDT Assemblies can be accessed from the **MDT Assemblies** tool palette and can be used for the initial modeling of MDT roadway designs. MDT Assemblies are constructed from custom MDT Subassemblies.

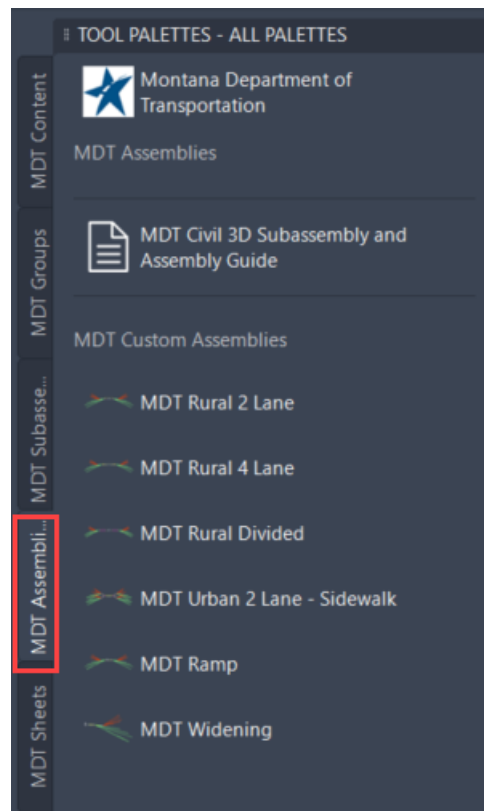

MDT RURAL 2 LANE

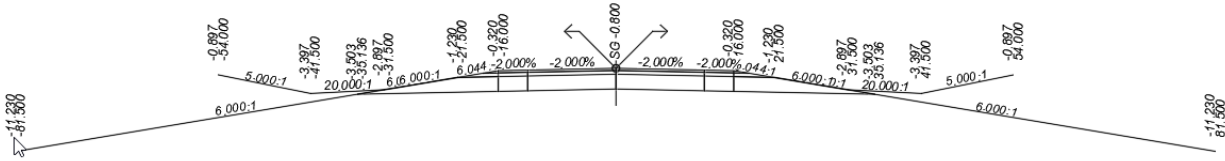

Rural Undivided 2 Lane – GDS 2.4 / RDM 5-19
12' Lanes, 4' Shoulder, Rural Slope Table

Subassemblies Included:

Left	Right
MDT Parameter References	MDT Parameter References
MDT Lane-Lane	MDT Lane-Lane
MDT Lane-Shld	MDT Lane-Shld
MDT Shoulder	MDT Shoulder
MDT Daylight With Subbase	MDT Daylight With Subbase

Parameter References for Right Side (Left is the same):

- MDT Parameter Reference

Input values:

Value Name	Default Input Value	Parameter Reference	
		Use	Get Value From
Side	Right	<input type="checkbox"/>	<None>
Pave1 depth	0.300'	<input type="checkbox"/>	<None>
Pave2 depth	0.000'	<input type="checkbox"/>	<None>
Base depth	0.500'	<input type="checkbox"/>	<None>
Subbase depth	2.000'	<input type="checkbox"/>	<None>
Lane 1 width	12.000'	<input type="checkbox"/>	<None>
Lane 2 width	4.000'	<input type="checkbox"/>	<None>
Lane 3 width	0.000'	<input type="checkbox"/>	<None>
Lane 4 width	0.000'	<input type="checkbox"/>	<None>
Lane 1 slope	-2.00%	<input type="checkbox"/>	<None>
Lane 2 slope	-2.00%	<input type="checkbox"/>	<None>
Lane 3 slope	-2.00%	<input type="checkbox"/>	<None>
Lane 4 slope	0.00%	<input type="checkbox"/>	<None>
Integer 1	0	<input type="checkbox"/>	<None>
Integer 2	0	<input type="checkbox"/>	<None>
Integer 3	0	<input type="checkbox"/>	<None>
Integer 4	0	<input type="checkbox"/>	<None>

- MDT Lane-Lane

Input values:

Value Name	Default Input Value	Parameter Reference	
		Use	Get Value From
Side	Right	<input type="checkbox"/>	<None>
Point Code Location Suffix	Automatic	<input type="checkbox"/>	<None>
Centerline	Attachment Point	<input type="checkbox"/>	<None>
Lane Width	12.000	<input checked="" type="checkbox"/>	Right-MDTParameterReferences.Lane 1 width value
Lane Slope	-2.00%	<input type="checkbox"/>	<None>
Slope Direction	Away from Crown	<input type="checkbox"/>	<None>
Pave1 Depth	0.300	<input checked="" type="checkbox"/>	Right-MDTParameterReferences.Pave1 depth value
Pave2 Depth	0.000	<input checked="" type="checkbox"/>	Right-MDTParameterReferences.Pave2 depth value
Base Depth	0.500	<input checked="" type="checkbox"/>	Right-MDTParameterReferences.Base depth value
Subbase Depth	2.000	<input checked="" type="checkbox"/>	Right-MDTParameterReferences.Subbase depth value
Use Superelevation	Right Outside Lane Slope	<input type="checkbox"/>	<None>
Base Extension Inside Width	0.000	<input type="checkbox"/>	<None>
Base Extension Outside Width	0.000	<input type="checkbox"/>	<None>
Add Construction Slope	No	<input type="checkbox"/>	<None>
Construction Slope	2.00:1	<input type="checkbox"/>	<None>
Custom Point Code Suffix	_L-In	<input type="checkbox"/>	<None>

- MDT Lane-Shld

Input values:

Value Name	Default Input Value	Parameter Reference	
		Use	Get Value From
Side	Right	<input type="checkbox"/>	<None>
Point Code Location Suffix	Automatic	<input type="checkbox"/>	<None>
Centerline	Attachment Point	<input type="checkbox"/>	<None>
Lane Width	4.000	<input checked="" type="checkbox"/>	Right-MDTParameterReferences.Lane 2 width value
Lane Slope	-2.00%	<input checked="" type="checkbox"/>	Right-MDTLane-Lane.Lane Slope value %
Slope Direction	Away from Crown	<input type="checkbox"/>	<None>
Pave1 Depth	0.300	<input checked="" type="checkbox"/>	Right-MDTParameterReferences.Pave1 depth value
Pave2 Depth	0.000	<input checked="" type="checkbox"/>	Right-MDTParameterReferences.Pave2 depth value
Base Depth	0.500	<input checked="" type="checkbox"/>	Right-MDTParameterReferences.Base depth value
Subbase Depth	2.000	<input checked="" type="checkbox"/>	Right-MDTParameterReferences.Subbase depth value
Use Superelevation	None	<input type="checkbox"/>	<None>
Base Extension Inside Width	0.000	<input type="checkbox"/>	<None>
Base Extension Outside Width	0.000	<input type="checkbox"/>	<None>
Add Construction Slope	No	<input type="checkbox"/>	<None>
Construction Slope	2.00:1	<input type="checkbox"/>	<None>
Custom Point Code Suffix	_L-In	<input type="checkbox"/>	<None>

- MDT Shoulder

Input values:

Value Name	Default Input Value	Parameter Reference	
		Use	Get Value From
Side	Right	<input type="checkbox"/>	<None>
Point Code Location Suffix	Automatic	<input type="checkbox"/>	<None>
Pave1 Depth	0.300	<input checked="" type="checkbox"/>	Right-MDTParameterReferences.Pave1 depth value
Pave2 Depth	0.000	<input checked="" type="checkbox"/>	Right-MDTParameterReferences.Pave2 depth value
Base Depth	0.500	<input checked="" type="checkbox"/>	Right-MDTParameterReferences.Base depth value
Pave Slope (Referenced from Lane)	-2.00%	<input checked="" type="checkbox"/>	Right-MDTLane-Lane.Lane Slope value %
Normal Crown Slope	-2.00%	<input type="checkbox"/>	<None>
Surfacing Inslope	6.00:1	<input type="checkbox"/>	<None>
Use Superelevation	None	<input type="checkbox"/>	<None>
Inslope Extension Offset	0.000	<input type="checkbox"/>	<None>
Geotextile Outside Edge Offset	3.000	<input type="checkbox"/>	<None>
Custom Point Code Suffix	_L-In	<input type="checkbox"/>	<None>

- MDT Daylight With Subbase

Input values:

Value Name	Default Input Value	Parameter Reference	
		Use	Get Value From
Side	Right	<input type="checkbox"/>	<None>
Select Subassembly build options	Daylight with Subbase	<input type="checkbox"/>	<None>
Point Code Location Suffix	Automatic	<input type="checkbox"/>	<None>
End Condition Options	Automatic	<input type="checkbox"/>	<None>
Foreslope	6.00:1	<input type="checkbox"/>	<None>
Foreslope Width	10.000	<input type="checkbox"/>	<None>
Ditch Width	10.000	<input type="checkbox"/>	<None>
Ditch Slope	-20.00:1	<input type="checkbox"/>	<None>
Minimum Ditch Depth	0.500	<input type="checkbox"/>	<None>
Cut Slope	-20.00:1	<input type="checkbox"/>	<None>
Pave1 Depth (Referenced from Lane)	0.300	<input checked="" type="checkbox"/>	Right-MDTParameterReferences.Pave1 depth value
Pave2 Depth (Referenced from Lane)	0.000	<input checked="" type="checkbox"/>	Right-MDTParameterReferences.Pave2 depth value
Base Depth (Referenced from Lane)	0.500	<input checked="" type="checkbox"/>	Right-MDTParameterReferences.Base depth value
Subbase Depth (Referenced from L...	2.000	<input checked="" type="checkbox"/>	Right-MDTParameterReferences.Subbase depth value
Normal Crown Base Distance (Refe...	5.500	<input checked="" type="checkbox"/>	Right-MDTShoulder.Normal Crown Base Distance value
Normal Crown Slope (Referenced f...	-2.00%	<input checked="" type="checkbox"/>	Right-MDTShoulder.Normal Crown Slope value
SE Base Distance (Referenced from...	5.500	<input checked="" type="checkbox"/>	Right-MDTShoulder.SE Base Distance value
SE Base Slope (Referenced from S...	-2.00%	<input checked="" type="checkbox"/>	Right-MDTShoulder.SE Base Slope value
Inslope Extension Offset (Referenc...	0.000	<input checked="" type="checkbox"/>	Right-MDTShoulder.Inslope Extension value
Rounded Surface Inslope (Referenc...	-0.165	<input checked="" type="checkbox"/>	Right-MDTShoulder.Rounded Surfacing Inslope value
Create Bathtub	Yes	<input type="checkbox"/>	<None>
Bathtub Slope	2.00:1	<input type="checkbox"/>	<None>
Custom Point Code Suffix	_L-In	<input type="checkbox"/>	<None>

MDT RURAL 4 LANE

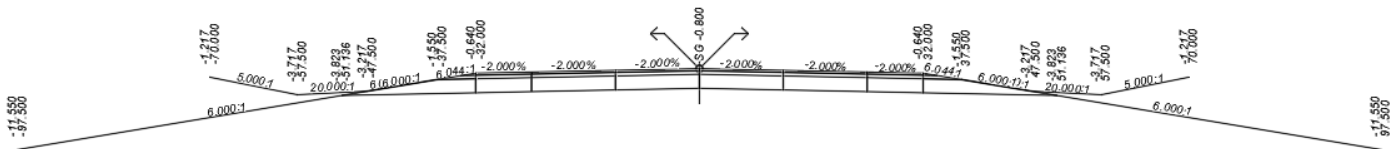

Rural Undivided 4 Lane – GDS 2.2 / RDM 5-9 (Outsides)

12' Lanes (2 each direction, BL / PGL at center), 8' Shoulder, Rural Slope Table

Subassemblies Included:

Left	Right
MDT Parameter References	MDT Parameter References
MDT Lane-Lane_In	MDT Lane-Lane_In
MDT Lane-Lane_Out	MDT Lane-Lane_Out
MDT Lane-Shld	MDT Lane-Shld
MDT Shoulder	MDT Shoulder
MDT Daylight With Subbase	MDT Daylight With Subbase

Parameter References for Right Side (Left is the same):

- MDT Parameter Reference

Input values:

Value Name	Default Input Value	Parameter Reference	
		Use	Get Value From
Side	Right	<input type="checkbox"/>	<None>
Pave1 depth	0.300'	<input type="checkbox"/>	<None>
Pave2 depth	0.000'	<input type="checkbox"/>	<None>
Base depth	0.500'	<input type="checkbox"/>	<None>
Subbase depth	2.000'	<input type="checkbox"/>	<None>
Lane 1 width	12.000'	<input type="checkbox"/>	<None>
Lane 2 width	12.000'	<input type="checkbox"/>	<None>
Lane 3 width	8.000'	<input type="checkbox"/>	<None>
Lane 4 width	0.000'	<input type="checkbox"/>	<None>
Lane 1 slope	-2.00%	<input type="checkbox"/>	<None>
Lane 2 slope	-2.00%	<input type="checkbox"/>	<None>
Lane 3 slope	-2.00%	<input type="checkbox"/>	<None>
Lane 4 slope	-2.00%	<input type="checkbox"/>	<None>
Integer 1	0	<input type="checkbox"/>	<None>
Integer 2	0	<input type="checkbox"/>	<None>
Integer 3	0	<input type="checkbox"/>	<None>
Integer 4	0	<input type="checkbox"/>	<None>

- MDT Lane-Lane_In

Input values:

Value Name	Default Input Value	Parameter Reference	
		Use	Get Value From
Side	Right	<input type="checkbox"/>	<None>
Point Code Location Suffix	Automatic	<input type="checkbox"/>	<None>
Centerline	Attachment Point	<input type="checkbox"/>	<None>
Lane Width	12.000	<input checked="" type="checkbox"/>	Right-MDTParameterReferences.Lane 1 width value
Lane Slope	-2.00%	<input type="checkbox"/>	<None>
Slope Direction	Away from Crown	<input type="checkbox"/>	<None>
Pave1 Depth	0.300	<input checked="" type="checkbox"/>	Right-MDTParameterReferences.Pave1 depth value
Pave2 Depth	0.000	<input checked="" type="checkbox"/>	Right-MDTParameterReferences.Pave2 depth value
Base Depth	0.500	<input checked="" type="checkbox"/>	Right-MDTParameterReferences.Base depth value
Subbase Depth	2.000	<input checked="" type="checkbox"/>	Right-MDTParameterReferences.Subbase depth value
Use Superelevation	Right Outside Lane Slope	<input type="checkbox"/>	<None>
Base Extension Inside Width	0.000	<input type="checkbox"/>	<None>
Base Extension Outside Width	0.000	<input type="checkbox"/>	<None>
Add Construction Slope	No	<input type="checkbox"/>	<None>
Construction Slope	2.00:1	<input type="checkbox"/>	<None>
Custom Point Code Suffix	_L-In	<input type="checkbox"/>	<None>

- MDT Lane-Lane_Out

Input values:

Value Name	Default Input Value	Parameter Reference	
		Use	Get Value From
Side	Right	<input type="checkbox"/>	<None>
Point Code Location Suffix	Automatic	<input type="checkbox"/>	<None>
Centerline	Attachment Point	<input type="checkbox"/>	<None>
Lane Width	12.000	<input checked="" type="checkbox"/>	Right-MDTParameterReferences.Lane 2 width value
Lane Slope	-2.00%	<input checked="" type="checkbox"/>	Right-MDTLane-Lane_In.Lane Slope value %
Slope Direction	Away from Crown	<input type="checkbox"/>	<None>
Pave1 Depth	0.300	<input checked="" type="checkbox"/>	Right-MDTParameterReferences.Pave1 depth value
Pave2 Depth	0.000	<input checked="" type="checkbox"/>	Right-MDTParameterReferences.Pave2 depth value
Base Depth	0.500	<input checked="" type="checkbox"/>	Right-MDTParameterReferences.Base depth value
Subbase Depth	2.000	<input checked="" type="checkbox"/>	Right-MDTParameterReferences.Subbase depth value
Use Superelevation	None	<input type="checkbox"/>	<None>
Base Extension Inside Width	0.000	<input type="checkbox"/>	<None>
Base Extension Outside Width	0.000	<input type="checkbox"/>	<None>
Add Construction Slope	No	<input type="checkbox"/>	<None>
Construction Slope	2.00:1	<input type="checkbox"/>	<None>
Custom Point Code Suffix	_L-In	<input type="checkbox"/>	<None>

- MDT Lane-Shld

Input values:

Value Name	Default Input Value	Parameter Reference	
		Use	Get Value From
Side	Right	<input type="checkbox"/>	<None>
Point Code Location Suffix	Automatic	<input type="checkbox"/>	<None>
Centerline	Attachment Point	<input type="checkbox"/>	<None>
Lane Width	8.000	<input checked="" type="checkbox"/>	Right-MDTParameterReferences.Lane 3 width value
Lane Slope	-2.00%	<input checked="" type="checkbox"/>	Right-MDTLane-Lane_In.Lane Slope value %
Slope Direction	Away from Crown	<input type="checkbox"/>	<None>
Pave1 Depth	0.300	<input checked="" type="checkbox"/>	Right-MDTParameterReferences.Pave1 depth value
Pave2 Depth	0.000	<input checked="" type="checkbox"/>	Right-MDTParameterReferences.Pave2 depth value
Base Depth	0.500	<input checked="" type="checkbox"/>	Right-MDTParameterReferences.Base depth value
Subbase Depth	2.000	<input checked="" type="checkbox"/>	Right-MDTParameterReferences.Subbase depth value
Use Superelevation	None	<input type="checkbox"/>	<None>
Base Extension Inside Width	0.000	<input type="checkbox"/>	<None>
Base Extension Outside Width	0.000	<input type="checkbox"/>	<None>
Add Construction Slope	No	<input type="checkbox"/>	<None>
Construction Slope	2.00:1	<input type="checkbox"/>	<None>
Custom Point Code Suffix	_L-In	<input type="checkbox"/>	<None>

- MDT Shoulder

Input values:

Value Name	Default Input Value	Parameter Reference	
		Use	Get Value From
Side	Right	<input type="checkbox"/>	<None>
Point Code Location Suffix	Automatic	<input type="checkbox"/>	<None>
Pave1 Depth	0.300	<input checked="" type="checkbox"/>	Right-MDTParameterReferences.Pave1 depth value
Pave2 Depth	0.000	<input checked="" type="checkbox"/>	Right-MDTParameterReferences.Pave2 depth value
Base Depth	0.500	<input checked="" type="checkbox"/>	Right-MDTParameterReferences.Base depth value
Pave Slope (Referenced from Lane)	-2.00%	<input checked="" type="checkbox"/>	Right-MDTLane-Lane_In.Lane Slope value %
Normal Crown Slope	-2.00%	<input type="checkbox"/>	<None>
Surfacing Inslope	6.00:1	<input type="checkbox"/>	<None>
Use Superelevation	None	<input type="checkbox"/>	<None>
Inslope Extension Offset	0.000	<input type="checkbox"/>	<None>
Geotextile Outside Edge Offset	3.000	<input type="checkbox"/>	<None>
Custom Point Code Suffix	_L-In	<input type="checkbox"/>	<None>

- MDT Daylight With Subbase

Input values:

Value Name	Default Input Value	Parameter Reference	
		Use	Get Value From
Side	Right	<input type="checkbox"/>	<None>
Select Subassembly build options	Daylight with Subbase	<input type="checkbox"/>	<None>
Point Code Location Suffix	Automatic	<input type="checkbox"/>	<None>
End Condition Options	Automatic	<input type="checkbox"/>	<None>
Foreslope	6.00:1	<input type="checkbox"/>	<None>
Foreslope Width	10.000	<input type="checkbox"/>	<None>
Ditch Width	10.000	<input type="checkbox"/>	<None>
Ditch Slope	-20.00:1	<input type="checkbox"/>	<None>
Minimum Ditch Depth	0.500	<input type="checkbox"/>	<None>
Cut Slope	-20.00:1	<input type="checkbox"/>	<None>
Pave1 Depth (Referenced from Lane)	0.300	<input checked="" type="checkbox"/>	Right-MDTParameterReferences.Pave1 depth value
Pave2 Depth (Referenced from Lane)	0.000	<input checked="" type="checkbox"/>	Right-MDTParameterReferences.Pave2 depth value
Base Depth (Referenced from Lane)	0.500	<input checked="" type="checkbox"/>	Right-MDTParameterReferences.Base depth value
Subbase Depth (Referenced from L...	2.000	<input checked="" type="checkbox"/>	Right-MDTParameterReferences.Subbase depth value
Normal Crown Base Distance (Refer...	5.500	<input checked="" type="checkbox"/>	Right-MDTShoulder.Normal Crown Base Distance value
Normal Crown Slope (Referenced fr...	-2.00%	<input checked="" type="checkbox"/>	Right-MDTShoulder.Normal Crown Slope value
SE Base Distance (Referenced from...	5.500	<input checked="" type="checkbox"/>	Right-MDTShoulder.SE Base Distance value
SE Base Slope (Referenced from S...	-2.00%	<input checked="" type="checkbox"/>	Right-MDTShoulder.SE Base Slope value
Inslope Extension Offset (Referenc...	0.000	<input checked="" type="checkbox"/>	Right-MDTShoulder.Inslope Extension value
Rounded Surface Inslope (Referenc...	-0.165	<input checked="" type="checkbox"/>	Right-MDTShoulder.Rounded Surfacing Inslope value
Create Bathtub	Yes	<input type="checkbox"/>	<None>
Bathtub Slope	2.00:1	<input type="checkbox"/>	<None>
Custom Point Code Suffix	1-In	<input type="checkbox"/>	<None>

MDT RURAL DIVIDED

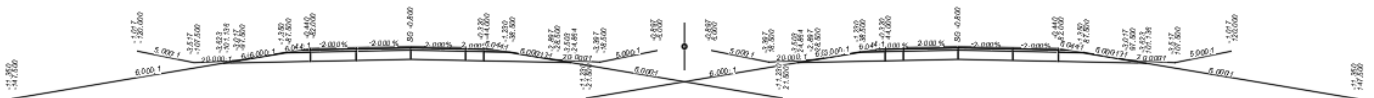

Rural Divided – GDS 2.1 / RDM 5-9

12' Lanes (2 each direction, BL / PGL between lanes), 4' Inside Shoulder,

10' Outside Shoulder, 36' Median, Rural Slope Table

Generic Link components should be used within the median area to achieve the desired configuration of the final median shape or internal daylighting.

Subassemblies Included:

Left	Right
Link Width and Slope-CL-Offset	Link Width and Slope-CL-Offset
Out-MDT Lane-Lane	Out-MDT Lane-Lane
Out-MDT Lane-Shld	Out-MDT Lane-Shld
Out-MDT Shoulder	Out-MDT Shoulder
Out-MDT Daylight With Subbase	Out-MDT Daylight With Subbase
In-MDT Lane-Lane	In-MDT Lane-Lane
In-MDT Lane-Shld	In-MDT Lane-Shld
In-MDT Shoulder	In-MDT Shoulder
In-MDT Daylight With Subbase	In-MDT Daylight With Subbase

Parameter References for Right Side (Left is the same except for “Left” prefixes):

- Link Width and Slope-CL-Offset

Value Name	Default Input Value	Parameter Reference	
		Use	Get Value From
Side	Right	<input type="checkbox"/>	<None>
Width	60.000'	<input type="checkbox"/>	<None>
Use Superelevation Slope	No	<input type="checkbox"/>	<None>
Slope Direction	Away from Crown	<input type="checkbox"/>	<None>
Slope	0.00%	<input type="checkbox"/>	<None>
Point Codes		<input type="checkbox"/>	<None>
Link Codes	Top,Datum	<input type="checkbox"/>	<None>
Omit Link	Yes	<input type="checkbox"/>	<None>

- Out-MDT Lane-Lane

Input values:

Value Name	Default Input Value	Parameter Reference	
		Use	Get Value From
Side	Right	<input type="checkbox"/>	<None>
Point Code Location Suffix	Custom Suffix	<input type="checkbox"/>	<None>
Centerline	Attachment Point	<input type="checkbox"/>	<None>
Lane Width	12.000	<input type="checkbox"/>	<None>
Lane Slope	-2.00%	<input type="checkbox"/>	<None>
Slope Direction	Away from Crown	<input type="checkbox"/>	<None>
Pave1 Depth	0.300	<input type="checkbox"/>	<None>
Pave2 Depth	0.000	<input type="checkbox"/>	<None>
Base Depth	0.500	<input type="checkbox"/>	<None>
Subbase Depth	2.000	<input type="checkbox"/>	<None>
Use Superelevation	Right Outside Lane Slope	<input type="checkbox"/>	<None>
Base Extension Inside Width	0.000	<input type="checkbox"/>	<None>
Base Extension Outside Width	0.000	<input type="checkbox"/>	<None>
Add Construction Slope	No	<input type="checkbox"/>	<None>
Construction Slope	2.00:1	<input type="checkbox"/>	<None>
Custom Point Code Suffix	_R-Out	<input type="checkbox"/>	<None>

- Out-MDT Lane-Shld

Input values:

Value Name	Default Input Value	Parameter Reference	
		Use	Get Value From
Side	Right	<input type="checkbox"/>	<None>
Point Code Location Suffix	Custom Suffix	<input type="checkbox"/>	<None>
Centerline	Attachment Point	<input type="checkbox"/>	<None>
Lane Width	10.000	<input type="checkbox"/>	<None>
Lane Slope	-2.00%	<input checked="" type="checkbox"/>	Right-Out-MDTLane-Lane.Lane Slope value %
Slope Direction	Away from Crown	<input type="checkbox"/>	<None>
Pave1 Depth	0.300	<input checked="" type="checkbox"/>	Right-Out-MDTLane-Lane.Pave1 Depth value
Pave2 Depth	0.000	<input checked="" type="checkbox"/>	Right-Out-MDTLane-Lane.Pave2 Depth value
Base Depth	0.500	<input checked="" type="checkbox"/>	Right-Out-MDTLane-Lane.Base Depth value
Subbase Depth	2.000	<input checked="" type="checkbox"/>	Right-Out-MDTLane-Lane.Subbase Depth value
Use Superelevation	None	<input type="checkbox"/>	<None>
Base Extension Inside Width	0.000	<input type="checkbox"/>	<None>
Base Extension Outside Width	0.000	<input type="checkbox"/>	<None>
Add Construction Slope	No	<input type="checkbox"/>	<None>
Construction Slope	2.00:1	<input type="checkbox"/>	<None>
Custom Point Code Suffix	_R-Out	<input type="checkbox"/>	<None>

- Out-MDT Shoulder

Input values:

Value Name	Default Input Value	Parameter Reference	
		Use	Get Value From
Side	Right	<input type="checkbox"/>	<None>
Point Code Location Suffix	Custom Suffix	<input type="checkbox"/>	<None>
Pave1 Depth	0.300	<input checked="" type="checkbox"/>	Right-Out-MDTLane-Lane.Pave1 Depth value
Pave2 Depth	0.000	<input checked="" type="checkbox"/>	Right-Out-MDTLane-Lane.Pave2 Depth value
Base Depth	0.500	<input checked="" type="checkbox"/>	Right-Out-MDTLane-Lane.Base Depth value
Pave Slope (Referenced from Lane)	-2.00%	<input checked="" type="checkbox"/>	Right-Out-MDTLane-Lane.Lane Slope value %
Normal Crown Slope	-2.00%	<input type="checkbox"/>	<None>
Surfacing Inslope	6.00:1	<input type="checkbox"/>	<None>
Use Superelevation	None	<input type="checkbox"/>	<None>
Inslope Extension Offset	0.000	<input type="checkbox"/>	<None>
Geotextile Outside Edge Offset	3.000	<input type="checkbox"/>	<None>
Custom Point Code Suffix	_R-Out	<input type="checkbox"/>	<None>

- Out-MDT Daylight With Subbase

Input values:

Value Name	Default Input Value	Parameter Reference	
		Use	Get Value From
Side	Right	<input type="checkbox"/>	<None>
Select Subassembly build options	Daylight with Subbase	<input type="checkbox"/>	<None>
Point Code Location Suffix	Custom Suffix	<input type="checkbox"/>	<None>
End Condition Options	Automatic	<input type="checkbox"/>	<None>
Foreslope	6.00:1	<input type="checkbox"/>	<None>
Foreslope Width	10.000	<input type="checkbox"/>	<None>
Ditch Width	10.000	<input type="checkbox"/>	<None>
Ditch Slope	-20.00:1	<input type="checkbox"/>	<None>
Minimum Ditch Depth	0.500	<input type="checkbox"/>	<None>
Cut Slope	-20.00:1	<input type="checkbox"/>	<None>
Pave1 Depth (Referenced from Lane)	0.300	<input checked="" type="checkbox"/>	Right-Out-MDTLane-Lane.Pave1 Depth value
Pave2 Depth (Referenced from Lane)	0.000	<input checked="" type="checkbox"/>	Right-Out-MDTLane-Lane.Pave2 Depth value
Base Depth (Referenced from Lane)	0.500	<input checked="" type="checkbox"/>	Right-Out-MDTLane-Lane.Base Depth value
Subbase Depth (Referenced from Lane)	2.000	<input checked="" type="checkbox"/>	Right-Out-MDTLane-Lane.Subbase Depth value
Normal Crown Base Distance (Referenced from Sho...	5.500	<input checked="" type="checkbox"/>	Right-Out-MDTShoulder.Normal Crown Base Distance value
Normal Crown Slope (Referenced from Shoulder)	-2.00%	<input checked="" type="checkbox"/>	Right-Out-MDTShoulder.Normal Crown Slope value
SE Base Distance (Referenced from Shoulder)	5.500	<input checked="" type="checkbox"/>	Right-Out-MDTShoulder.SE Base Distance value
SE Base Slope (Referenced from Shoulder)	-2.00%	<input checked="" type="checkbox"/>	Right-Out-MDTShoulder.SE Base Slope value
Inslope Extension Offset (Referenced from Shoulder)	0.000	<input checked="" type="checkbox"/>	Right-Out-MDTShoulder.Inslope Extension value
Rounded Surface Inslope (Referenced from Shoulder)	-0.165	<input checked="" type="checkbox"/>	Right-Out-MDTShoulder.Rounded Surfacing Inslope value
Create Bathtub	Yes	<input type="checkbox"/>	<None>
Bathtub Slope	2.00:1	<input type="checkbox"/>	<None>
Custom Point Code Suffix	_R-Out	<input type="checkbox"/>	<None>

- In-MDT Lane-Lane

Input values:

Value Name	Default Input Value	Parameter Reference	
		Use	Get Value From
Side	Left	<input type="checkbox"/>	<None>
Point Code Location Suffix	Custom Suffix	<input type="checkbox"/>	<None>
Centerline	Attachment Point	<input type="checkbox"/>	<None>
Lane Width	12.000	<input type="checkbox"/>	<None>
Lane Slope	-2.00%	<input type="checkbox"/>	<None>
Slope Direction	Away from Crown	<input type="checkbox"/>	<None>
Pave1 Depth	0.300	<input type="checkbox"/>	<None>
Pave2 Depth	0.000	<input type="checkbox"/>	<None>
Base Depth	0.500	<input type="checkbox"/>	<None>
Subbase Depth	2.000	<input type="checkbox"/>	<None>
Use Superelevation	Left Outside Lane Slope	<input type="checkbox"/>	<None>
Base Extension Inside Width	0.000	<input type="checkbox"/>	<None>
Base Extension Outside Width	0.000	<input type="checkbox"/>	<None>
Add Construction Slope	No	<input type="checkbox"/>	<None>
Construction Slope	2.00:1	<input type="checkbox"/>	<None>
Custom Point Code Suffix	_R-In	<input type="checkbox"/>	<None>

- In-MDT Lane-Shld

Input values:

Value Name	Default Input Value	Parameter Reference	
		Use	Get Value From
Side	Left	<input type="checkbox"/>	<None>
Point Code Location Suffix	Custom Suffix	<input type="checkbox"/>	<None>
Centerline	Attachment Point	<input type="checkbox"/>	<None>
Lane Width	4.000	<input type="checkbox"/>	<None>
Lane Slope	-2.00%	<input checked="" type="checkbox"/>	Right-In-MDTLane-Lane.Lane Slope value %
Slope Direction	Away from Crown	<input type="checkbox"/>	<None>
Pave1 Depth	0.300	<input checked="" type="checkbox"/>	Right-In-MDTLane-Lane.Pave1 Depth value
Pave2 Depth	0.000	<input checked="" type="checkbox"/>	Right-In-MDTLane-Lane.Pave2 Depth value
Base Depth	0.500	<input checked="" type="checkbox"/>	Right-In-MDTLane-Lane.Base Depth value
Subbase Depth	2.000	<input checked="" type="checkbox"/>	Right-In-MDTLane-Lane.Subbase Depth value
Use Superelevation	None	<input type="checkbox"/>	<None>
Base Extension Inside Width	0.000	<input type="checkbox"/>	<None>
Base Extension Outside Width	0.000	<input type="checkbox"/>	<None>
Add Construction Slope	No	<input type="checkbox"/>	<None>
Construction Slope	2.00:1	<input type="checkbox"/>	<None>
Custom Point Code Suffix	_R-In	<input type="checkbox"/>	<None>

- In-MDT Shoulder

Input values:

Value Name	Default Input Value	Parameter Reference	
		Use	Get Value From
Side	Left	<input type="checkbox"/>	<None>
Point Code Location Suffix	Custom Suffix	<input type="checkbox"/>	<None>
Pave1 Depth	0.300	<input checked="" type="checkbox"/>	Right-In-MDTLane-Lane.Pave1 Depth value
Pave2 Depth	0.000	<input checked="" type="checkbox"/>	Right-In-MDTLane-Lane.Pave2 Depth value
Base Depth	0.500	<input checked="" type="checkbox"/>	Right-In-MDTLane-Lane.Base Depth value
Pave Slope (Referenced from Lane)	-2.00%	<input checked="" type="checkbox"/>	Right-In-MDTLane-Lane.Lane Slope value %
Normal Crown Slope	-2.00%	<input type="checkbox"/>	<None>
Surfacing Inslope	6.00:1	<input type="checkbox"/>	<None>
Use Superelevation	None	<input type="checkbox"/>	<None>
Inslope Extension Offset	0.000	<input type="checkbox"/>	<None>
Geotextile Outside Edge Offset	3.000	<input type="checkbox"/>	<None>
Custom Point Code Suffix	_R-In	<input type="checkbox"/>	<None>

- In-MDT Daylight With Subbase

Input values:

Value Name	Default Input Value	Parameter Reference	
		Use	Get Value From
Side	Left	<input type="checkbox"/>	<None>
Select Subassembly build options	Daylight with Subbase	<input type="checkbox"/>	<None>
Point Code Location Suffix	Custom Suffix	<input type="checkbox"/>	<None>
End Condition Options	Automatic	<input type="checkbox"/>	<None>
Foreslope	6.00:1	<input type="checkbox"/>	<None>
Foreslope Width	10.000	<input type="checkbox"/>	<None>
Ditch Width	10.000	<input type="checkbox"/>	<None>
Ditch Slope	-20.00:1	<input type="checkbox"/>	<None>
Minimum Ditch Depth	0.500	<input type="checkbox"/>	<None>
Cut Slope	-20.00:1	<input type="checkbox"/>	<None>
Pave1 Depth (Referenced from Lane)	0.300	<input checked="" type="checkbox"/>	Right-In-MDTLane-Lane.Pave1 Depth value
Pave2 Depth (Referenced from Lane)	0.000	<input checked="" type="checkbox"/>	Right-In-MDTLane-Lane.Pave2 Depth value
Base Depth (Referenced from Lane)	0.500	<input checked="" type="checkbox"/>	Right-In-MDTLane-Lane.Base Depth value
Subbase Depth (Referenced from Lane)	2.000	<input checked="" type="checkbox"/>	Right-In-MDTLane-Lane.Subbase Depth value
Normal Crown Base Distance (Referenced from Sho...	5.500	<input checked="" type="checkbox"/>	Right-In-MDTShoulder.Normal Crown Base Distance value
Normal Crown Slope (Referenced from Shoulder)	-2.00%	<input checked="" type="checkbox"/>	Right-In-MDTShoulder.SE Base Slope value
SE Base Distance (Referenced from Shoulder)	5.500	<input checked="" type="checkbox"/>	Right-In-MDTShoulder.SE Base Distance value
SE Base Slope (Referenced from Shoulder)	-2.00%	<input checked="" type="checkbox"/>	Right-In-MDTShoulder.SE Base Slope value
Inslope Extension Offset (Referenced from Shoulder)	0.000	<input checked="" type="checkbox"/>	Right-In-MDTShoulder.Inslope Extension value
Rounded Surface Inslope (Referenced from Shoulder)	-0.165	<input checked="" type="checkbox"/>	Right-In-MDTShoulder.Rounded Surfacing Inslope value
Create Bathtub	Yes	<input type="checkbox"/>	<None>
Bathtub Slope	2.00:1	<input type="checkbox"/>	<None>
Custom Point Code Suffix	_R-In	<input type="checkbox"/>	<None>

MDT URBAN 2 LANE – SIDEWALK

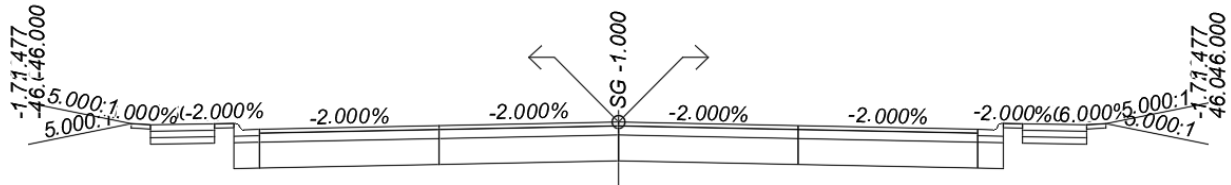

Urban Undivided with Sidewalk – GDS 3.5 / RDM 5.21

14' Lanes, MDT Curb, 3' Boulevard / Buffer, 5' Sidewalk, 1.5-3' PI / Buffer, Urban Slope Table

Subassemblies Included:

Left	Right
MDT Parameter References	MDT Parameter References
MDT Lane-Lane	MDT Lane-Lane
MDT Lane-Shld	MDT Lane-Shld
MDT Curb and Gutter	MDT Curb and Gutter
MDT Sidewalk	MDT Sidewalk
MDT Slope to Surface Link	MDT Slope to Surface Link

Parameter References for Right Side (Left is the same except for “Left” prefixes):

- MDT Parameter References

Input values:

Value Name	Default Input Value	Parameter Reference	
		Use	Get Value From
Side	Right	<input type="checkbox"/>	<None>
Pave1 depth	0.300'	<input type="checkbox"/>	<None>
Pave2 depth	0.000'	<input type="checkbox"/>	<None>
Base depth	0.700'	<input type="checkbox"/>	<None>
Subbase depth	2.000'	<input type="checkbox"/>	<None>
Lane 1 width	14.000'	<input type="checkbox"/>	<None>
Lane 2 width	14.000'	<input type="checkbox"/>	<None>
Lane 3 width	14.000'	<input type="checkbox"/>	<None>
Lane 4 width	14.000'	<input type="checkbox"/>	<None>
Lane 1 slope	-2.00%	<input type="checkbox"/>	<None>
Lane 2 slope	-2.00%	<input type="checkbox"/>	<None>
Lane 3 slope	-2.00%	<input type="checkbox"/>	<None>
Lane 4 slope	-2.00%	<input type="checkbox"/>	<None>
Integer 1	0	<input type="checkbox"/>	<None>
Integer 2	0	<input type="checkbox"/>	<None>
Integer 3	0	<input type="checkbox"/>	<None>
Integer 4	0	<input type="checkbox"/>	<None>

- MDT Lane-Lane

Input values:

Value Name	Default Input Value	Parameter Reference	
		Use	Get Value From
Side	Right	<input type="checkbox"/>	<None>
Point Code Location Suffix	Automatic	<input type="checkbox"/>	<None>
Centerline	Attachment Point	<input type="checkbox"/>	<None>
Lane Width	14.000	<input checked="" type="checkbox"/>	Right-MDTParameterReferences.Lane 1 width value
Lane Slope	-2.00%	<input type="checkbox"/>	<None>
Slope Direction	Away from Crown	<input type="checkbox"/>	<None>
Pave1 Depth	0.300	<input checked="" type="checkbox"/>	Right-MDTParameterReferences.Pave1 depth value
Pave2 Depth	0.000	<input checked="" type="checkbox"/>	Right-MDTParameterReferences.Pave2 depth value
Base Depth	0.700	<input checked="" type="checkbox"/>	Right-MDTParameterReferences.Base depth value
Subbase Depth	2.000	<input checked="" type="checkbox"/>	Right-MDTParameterReferences.Subbase depth value
Use Superelevation	Right Outside Lane Slope	<input type="checkbox"/>	<None>
Base Extension Inside Width	0.000	<input type="checkbox"/>	<None>
Base Extension Outside Width	0.000	<input type="checkbox"/>	<None>
Add Construction Slope	No	<input type="checkbox"/>	<None>
Construction Slope	2.00:1	<input type="checkbox"/>	<None>
Custom Point Code Suffix	_L-In	<input type="checkbox"/>	<None>

- MDT Lane-Shld

Input values:

Value Name	Default Input Value	Parameter Reference	
		Use	Get Value From
Side	Right	<input type="checkbox"/>	<None>
Point Code Location Suffix	Automatic	<input type="checkbox"/>	<None>
Centerline	Attachment Point	<input type="checkbox"/>	<None>
Lane Width	14.000	<input checked="" type="checkbox"/>	Right-MDTParameterReferences.Lane 2 width value
Lane Slope	-2.00%	<input checked="" type="checkbox"/>	Right-MDTLane-Lane.Lane Slope value %
Slope Direction	Away from Crown	<input type="checkbox"/>	<None>
Pave1 Depth	0.300	<input checked="" type="checkbox"/>	Right-MDTParameterReferences.Pave1 depth value
Pave2 Depth	0.000	<input checked="" type="checkbox"/>	Right-MDTParameterReferences.Pave2 depth value
Base Depth	0.700	<input checked="" type="checkbox"/>	Right-MDTParameterReferences.Base depth value
Subbase Depth	2.000	<input checked="" type="checkbox"/>	Right-MDTParameterReferences.Subbase depth value
Use Superelevation	None	<input type="checkbox"/>	<None>
Base Extension Inside Width	0.000	<input type="checkbox"/>	<None>
Base Extension Outside Width	0.000	<input type="checkbox"/>	<None>
Add Construction Slope	No	<input type="checkbox"/>	<None>
Construction Slope	2.00:1	<input type="checkbox"/>	<None>
Custom Point Code Suffix	_L-In	<input type="checkbox"/>	<None>

- MDT Curb and Gutter

Input values:

Value Name	Default Input Value	Parameter Reference	
		Use	Get Value From
Side	Right	<input type="checkbox"/>	<None>
Point Code Location Suffix	Automatic	<input type="checkbox"/>	<None>
Attachment Point	Front of Gutter	<input type="checkbox"/>	<None>
Curb Type	Standard	<input type="checkbox"/>	<None>
Base Depth	0.750	<input type="checkbox"/>	<None>
Base Slope (Referenced from Lane)	-2.00%	<input checked="" type="checkbox"/>	Right-MDTLane-Lane.Lane Slope value %
Subbase Depth	0.750	<input type="checkbox"/>	<None>
Subbase Slope (Referenced from Lane)	-2.00%	<input checked="" type="checkbox"/>	Right-MDTLane-Lane.Lane Slope value %
Gutter Slope Override	0.00%	<input type="checkbox"/>	<None>
Curb Base Slope Override	0.00%	<input type="checkbox"/>	<None>
Curb Width Override	0.000	<input type="checkbox"/>	<None>
Gutter Width Override	0.000	<input type="checkbox"/>	<None>
Curb Height Override	0.000	<input type="checkbox"/>	<None>
Lane Slope Override for Pindown and 4 in...	0.00%	<input type="checkbox"/>	<None>
Concrete Depth Override	0.000	<input type="checkbox"/>	<None>
Berm Width	3.000	<input type="checkbox"/>	<None>
Berm Slope	2.00%	<input type="checkbox"/>	<None>
Pavement Lip Height	0.000	<input type="checkbox"/>	<None>
Custom Point Code Suffix	_L-In	<input type="checkbox"/>	<None>

- MDT Sidewalk

Input values:

Value Name	Default Input Value	Parameter Reference	
		Use	Get Value From
Side	Right	<input type="checkbox"/>	<None>
Point Code Location Suffix	Automatic	<input type="checkbox"/>	<None>
Sidewalk Width	5.000	<input type="checkbox"/>	<None>
Sidewalk Slope	-1.50%	<input type="checkbox"/>	<None>
Sidewalk Depth	0.500	<input type="checkbox"/>	<None>
Sidewalk Base Depth	1.000	<input type="checkbox"/>	<None>
Sidewalk Subbase Depth	1.000	<input type="checkbox"/>	<None>
Sidewalk Berm Width	2.000	<input type="checkbox"/>	<None>
Sidewalk Berm Slope	3.00%	<input type="checkbox"/>	<None>
Custom Point Code Suffix	_L-In	<input type="checkbox"/>	<None>

- MDT Slope to Surface Link

Input values:

Value Name	Default Input Value	Parameter Reference	
		Use	Get Value From
Side	Right	<input type="checkbox"/>	<None>
Point Code Location Suffix	Automatic	<input type="checkbox"/>	<None>
Cut/Fill Option	Both	<input type="checkbox"/>	<None>
Cut Slope	5.00:1	<input type="checkbox"/>	<None>
Fill Slope	5.00:1	<input type="checkbox"/>	<None>
Number of Cut Intercepts (1 to 4)	1	<input type="checkbox"/>	<None>
Number of Fill Intercepts (1 to 4)	1	<input type="checkbox"/>	<None>
Material Thickness	0.000	<input type="checkbox"/>	<None>
Custom Point Code Suffix	_L-In	<input type="checkbox"/>	<None>

MDT RAMP

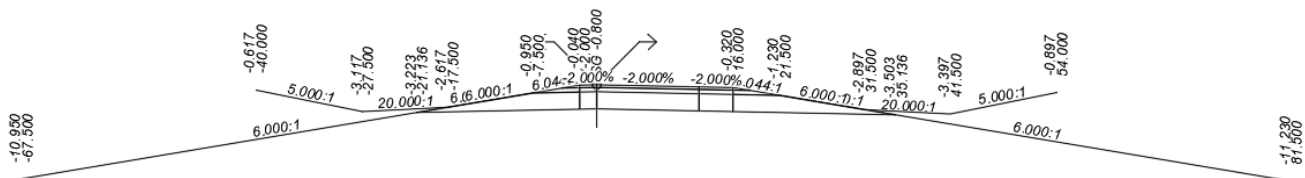

12' Lane RT (BL/PGL on Left edge)
 4' Shoulder RT, 2' Shoulder LT, Rural Slope Table

Subassemblies Included:

Left	Right
MDT Parameter References	MDT Parameter References
	MDT Lane-Lane
MDT Lane-Shld	MDT Lane-Shld
MDT Shoulder	MDT Shoulder
MDT Daylight With Subbase	MDT Daylight With Subbase

Parameter References for Right Side:

- Right MDT Parameter References

Input values:

Value Name	Default Input Value	Parameter Reference	
		Use	Get Value From
Side	Right	<input type="checkbox"/>	<None>
Pave1 depth	0.300'	<input type="checkbox"/>	<None>
Pave2 depth	0.000'	<input type="checkbox"/>	<None>
Base depth	0.500'	<input type="checkbox"/>	<None>
Subbase depth	2.000'	<input type="checkbox"/>	<None>
Lane 1 width	12.000'	<input type="checkbox"/>	<None>
Lane 2 width	4.000'	<input type="checkbox"/>	<None>
Lane 3 width	0.000'	<input type="checkbox"/>	<None>
Lane 4 width	0.000'	<input type="checkbox"/>	<None>
Lane 1 slope	-2.00%	<input type="checkbox"/>	<None>
Lane 2 slope	-2.00%	<input type="checkbox"/>	<None>
Lane 3 slope	-2.00%	<input type="checkbox"/>	<None>
Lane 4 slope	0.00%	<input type="checkbox"/>	<None>
Integer 1	0	<input type="checkbox"/>	<None>
Integer 2	0	<input type="checkbox"/>	<None>
Integer 3	0	<input type="checkbox"/>	<None>
Integer 4	0	<input type="checkbox"/>	<None>

- Right MDT Lane-Lane

Input values:

Value Name	Default Input Value	Parameter Reference	
		Use	Get Value From
Side	Right	<input type="checkbox"/>	<None>
Point Code Location Suffix	Automatic	<input type="checkbox"/>	<None>
Centerline	Attachment Point	<input type="checkbox"/>	<None>
Lane Width	12.000	<input checked="" type="checkbox"/>	Right-MDTParameterReferences.Lane 1 width value
Lane Slope	-2.00%	<input checked="" type="checkbox"/>	Right-MDTParameterReferences.Lane 1 slope value
Slope Direction	Away from Crown	<input type="checkbox"/>	<None>
Pave1 Depth	0.300	<input checked="" type="checkbox"/>	Right-MDTParameterReferences.Pave1 depth value
Pave2 Depth	0.000	<input checked="" type="checkbox"/>	Right-MDTParameterReferences.Pave2 depth value
Base Depth	0.500	<input checked="" type="checkbox"/>	Right-MDTParameterReferences.Base depth value
Subbase Depth	2.000	<input checked="" type="checkbox"/>	Right-MDTParameterReferences.Subbase depth value
Use Superelevation	Right Outside Lane Slope	<input type="checkbox"/>	<None>
Base Extension Inside Width	0.000	<input type="checkbox"/>	<None>
Base Extension Outside Width	0.000	<input type="checkbox"/>	<None>
Add Construction Slope	No	<input type="checkbox"/>	<None>
Construction Slope	2.00:1	<input type="checkbox"/>	<None>
Custom Point Code Suffix	_L-In	<input type="checkbox"/>	<None>

- Right MDT Lane-Shld

Input values:

Value Name	Default Input Value	Parameter Reference	
		Use	Get Value From
Side	Right	<input type="checkbox"/>	<None>
Point Code Location Suffix	Automatic	<input type="checkbox"/>	<None>
Centerline	Attachment Point	<input type="checkbox"/>	<None>
Lane Width	4.000	<input checked="" type="checkbox"/>	Right-MDTParameterReferences.Lane 2 width value
Lane Slope	-2.00%	<input checked="" type="checkbox"/>	Right-MDTLane-Lane.Lane Slope value %
Slope Direction	Away from Crown	<input type="checkbox"/>	<None>
Pave1 Depth	0.300	<input checked="" type="checkbox"/>	Right-MDTParameterReferences.Pave1 depth value
Pave2 Depth	0.000	<input checked="" type="checkbox"/>	Right-MDTParameterReferences.Pave2 depth value
Base Depth	0.500	<input checked="" type="checkbox"/>	Right-MDTParameterReferences.Base depth value
Subbase Depth	2.000	<input checked="" type="checkbox"/>	Right-MDTParameterReferences.Subbase depth value
Use Superelevation	None	<input type="checkbox"/>	<None>
Base Extension Inside Width	0.000	<input type="checkbox"/>	<None>
Base Extension Outside Width	0.000	<input type="checkbox"/>	<None>
Add Construction Slope	No	<input type="checkbox"/>	<None>
Construction Slope	2.00:1	<input type="checkbox"/>	<None>
Custom Point Code Suffix	_L-In	<input type="checkbox"/>	<None>

- Right MDT Shoulder

Input values:

Value Name	Default Input Value	Parameter Reference	
		Use	Get Value From
Side	Right	<input type="checkbox"/>	<None>
Point Code Location Suffix	Automatic	<input type="checkbox"/>	<None>
Pave1 Depth	0.300	<input checked="" type="checkbox"/>	Right-MDTParameterReferences.Pave1 depth value
Pave2 Depth	0.000	<input checked="" type="checkbox"/>	Right-MDTParameterReferences.Pave2 depth value
Base Depth	0.500	<input checked="" type="checkbox"/>	Right-MDTParameterReferences.Base depth value
Pave Slope (Referenced from Lane)	-2.00%	<input checked="" type="checkbox"/>	Right-MDTLane-Lane.Lane Slope value %
Normal Crown Slope	-2.00%	<input type="checkbox"/>	<None>
Surfacing Inslope	6.00:1	<input type="checkbox"/>	<None>
Use Superelevation	None	<input type="checkbox"/>	<None>
Inslope Extension Offset	0.000	<input type="checkbox"/>	<None>
Geotextile Outside Edge Offset	3.000	<input type="checkbox"/>	<None>
Custom Point Code Suffix	_L-In	<input type="checkbox"/>	<None>

- Right MDT Daylight with Subbase

Input values:

Value Name	Default Input Value	Parameter Reference	
		Use	Get Value From
Side	Right	<input type="checkbox"/>	<None>
Select Subassembly build options	Daylight with Subbase	<input type="checkbox"/>	<None>
Point Code Location Suffix	Automatic	<input type="checkbox"/>	<None>
End Condition Options	Automatic	<input type="checkbox"/>	<None>
Foreslope	6.00:1	<input type="checkbox"/>	<None>
Foreslope Width	10.000	<input type="checkbox"/>	<None>
Ditch Width	10.000	<input type="checkbox"/>	<None>
Ditch Slope	-20.00:1	<input type="checkbox"/>	<None>
Minimum Ditch Depth	0.500	<input type="checkbox"/>	<None>
Cut Slope	-20.00:1	<input type="checkbox"/>	<None>
Pave1 Depth (Referenced from Lane)	0.300	<input checked="" type="checkbox"/>	Right-MDTParameterReferences.Pave1 depth value
Pave2 Depth (Referenced from Lane)	0.000	<input checked="" type="checkbox"/>	Right-MDTParameterReferences.Pave2 depth value
Base Depth (Referenced from Lane)	0.500	<input checked="" type="checkbox"/>	Right-MDTParameterReferences.Base depth value
Subbase Depth (Referenced from L...	2.000	<input checked="" type="checkbox"/>	Right-MDTParameterReferences.Subbase depth value
Normal Crown Base Distance (Refer...	5.500	<input checked="" type="checkbox"/>	Right-MDTShoulder.Normal Crown Base Distance value
Normal Crown Slope (Referenced fr...	-2.00%	<input checked="" type="checkbox"/>	Right-MDTShoulder.Normal Crown Slope value
SE Base Distance (Referenced from...	5.500	<input checked="" type="checkbox"/>	Right-MDTShoulder.SE Base Distance value
SE Base Slope (Referenced from S...	-2.00%	<input checked="" type="checkbox"/>	Right-MDTShoulder.SE Base Slope value
Inslope Extension Offset (Reference...	0.000	<input checked="" type="checkbox"/>	Right-MDTShoulder.Inslope Extension value
Rounded Surface Inslope (Referenc...	-0.165	<input checked="" type="checkbox"/>	Right-MDTShoulder.Rounded Surfacing Inslope value
Create Bathtub	Yes	<input type="checkbox"/>	<None>
Bathtub Slope	2.00:1	<input type="checkbox"/>	<None>
Custom Point Code Suffix	1-In	<input type="checkbox"/>	<None>

Parameter References for Left Side:

- Left MDT Parameter References

Input values:

Value Name	Default Input Value	Parameter Reference	
		Use	Get Value From
Side	Left	<input type="checkbox"/>	<None>
Pave1 depth	0.300'	<input type="checkbox"/>	<None>
Pave2 depth	0.000'	<input type="checkbox"/>	<None>
Base depth	0.500'	<input type="checkbox"/>	<None>
Subbase depth	2.000'	<input type="checkbox"/>	<None>
Lane 1 width	2.000'	<input type="checkbox"/>	<None>
Lane 2 width	4.000'	<input type="checkbox"/>	<None>
Lane 3 width	0.000'	<input type="checkbox"/>	<None>
Lane 4 width	0.000'	<input type="checkbox"/>	<None>
Lane 1 slope	-2.00%	<input type="checkbox"/>	<None>
Lane 2 slope	-2.00%	<input type="checkbox"/>	<None>
Lane 3 slope	-2.00%	<input type="checkbox"/>	<None>
Lane 4 slope	0.00%	<input type="checkbox"/>	<None>
Integer 1	0	<input type="checkbox"/>	<None>
Integer 2	0	<input type="checkbox"/>	<None>
Integer 3	0	<input type="checkbox"/>	<None>
Integer 4	0	<input type="checkbox"/>	<None>

- Left MDT Lane Shoulder

Input values:

Value Name	Default Input Value	Parameter Reference	
		Use	Get Value From
Side	Left	<input type="checkbox"/>	<None>
Point Code Location Suffix	Automatic	<input type="checkbox"/>	<None>
Centerline	Attachment Point	<input type="checkbox"/>	<None>
Lane Width	2.000	<input checked="" type="checkbox"/>	Left-MDTParameterReferences.Lane 1 width value
Lane Slope	-2.00%	<input checked="" type="checkbox"/>	Left-MDTParameterReferences.Lane 1 slope value
Slope Direction	Away from Crown	<input type="checkbox"/>	<None>
Pave1 Depth	0.300	<input checked="" type="checkbox"/>	Left-MDTParameterReferences.Pave1 depth value
Pave2 Depth	0.000	<input checked="" type="checkbox"/>	Left-MDTParameterReferences.Pave2 depth value
Base Depth	0.500	<input checked="" type="checkbox"/>	Left-MDTParameterReferences.Base depth value
Subbase Depth	2.000	<input checked="" type="checkbox"/>	Left-MDTParameterReferences.Subbase depth value
Use Superelevation	Left Outside Lane Inverse	<input type="checkbox"/>	<None>
Base Extension Inside Width	0.000	<input type="checkbox"/>	<None>
Base Extension Outside Width	0.000	<input type="checkbox"/>	<None>
Add Construction Slope	No	<input type="checkbox"/>	<None>
Construction Slope	2.00:1	<input type="checkbox"/>	<None>
Custom Point Code Suffix	_L-In	<input type="checkbox"/>	<None>

- Left MDT Shoulder

Input values:

Value Name	Default Input Value	Parameter Reference	
		Use	Get Value From
Side	Left	<input type="checkbox"/>	<None>
Point Code Location Suffix	Automatic	<input type="checkbox"/>	<None>
Pave1 Depth	0.300	<input checked="" type="checkbox"/>	Left-MDTParameterReferences.Pave1 depth value
Pave2 Depth	0.000	<input checked="" type="checkbox"/>	Left-MDTParameterReferences.Pave2 depth value
Base Depth	0.500	<input checked="" type="checkbox"/>	Left-MDTParameterReferences.Base depth value
Pave Slope (Referenced from Lane)	-2.00%	<input checked="" type="checkbox"/>	Left-MDTLane-Shld.Lane Slope value %
Normal Crown Slope	-2.00%	<input type="checkbox"/>	<None>
Surfacing Inslope	6.00:1	<input type="checkbox"/>	<None>
Use Superelevation	None	<input type="checkbox"/>	<None>
Inslope Extension Offset	0.000	<input type="checkbox"/>	<None>
Geotextile Outside Edge Offset	3.000	<input type="checkbox"/>	<None>
Custom Point Code Suffix	_L-In	<input type="checkbox"/>	<None>

- Left MDT Daylight With Subbase

Input values:

Value Name	Default Input Value	Parameter Reference	
		Use	Get Value From
Side	Left	<input type="checkbox"/>	<None>
Select Subassembly build options	Daylight with Subbase	<input type="checkbox"/>	<None>
Point Code Location Suffix	Automatic	<input type="checkbox"/>	<None>
End Condition Options	Automatic	<input type="checkbox"/>	<None>
Foreslope	6.00:1	<input type="checkbox"/>	<None>
Foreslope Width	10.000	<input type="checkbox"/>	<None>
Ditch Width	10.000	<input type="checkbox"/>	<None>
Ditch Slope	-20.00:1	<input type="checkbox"/>	<None>
Minimum Ditch Depth	0.500	<input type="checkbox"/>	<None>
Cut Slope	-20.00:1	<input type="checkbox"/>	<None>
Pave1 Depth (Referenced from Lane)	0.300	<input checked="" type="checkbox"/>	Left-MDTParameterReferences.Pave1 depth value
Pave2 Depth (Referenced from Lane)	0.000	<input checked="" type="checkbox"/>	Left-MDTParameterReferences.Pave2 depth value
Base Depth (Referenced from Lane)	0.500	<input checked="" type="checkbox"/>	Left-MDTParameterReferences.Base depth value
Subbase Depth (Referenced from Lane)	2.000	<input checked="" type="checkbox"/>	Left-MDTParameterReferences.Subbase depth value
Normal Crown Base Distance (Referenced...	5.500	<input checked="" type="checkbox"/>	Left-MDTShoulder.Normal Crown Base Distance value
Normal Crown Slope (Referenced from Sh...	-2.00%	<input checked="" type="checkbox"/>	Left-MDTShoulder.Normal Crown Slope value
SE Base Distance (Referenced from Shoul...	5.500	<input checked="" type="checkbox"/>	Left-MDTShoulder.SE Base Distance value
SE Base Slope (Referenced from Shoulder)	-2.00%	<input checked="" type="checkbox"/>	Left-MDTShoulder.SE Base Slope value
Inslope Extension Offset (Referenced from...	0.000	<input checked="" type="checkbox"/>	Left-MDTShoulder.Inslope Extension value
Rounded Surface Inslope (Referenced fro...	-0.165	<input checked="" type="checkbox"/>	Left-MDTShoulder.Rounded Surfacing Inslope value
Create Bathtub	Yes	<input type="checkbox"/>	<None>
Bathtub Slope	2.00:1	<input type="checkbox"/>	<None>
Custom Point Code Suffix	_L-In	<input type="checkbox"/>	<None>

MDT WIDENING

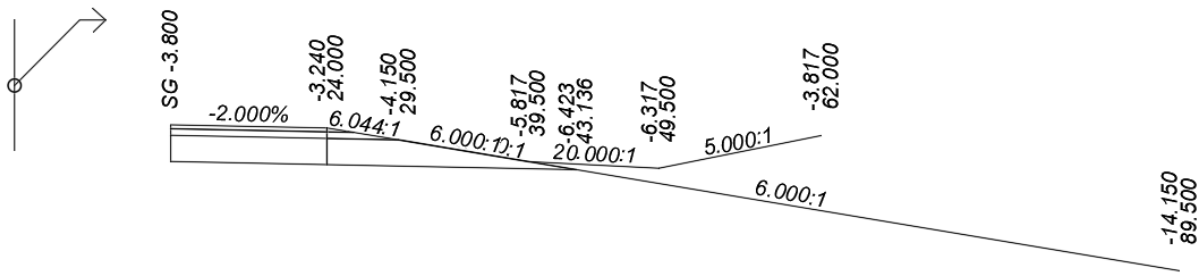

12' Lane RT

4' Shoulder RT, 2' Shoulder LT, Rural Slope Table

Subassemblies Included:

Right
MDT Parameter References
MDT Offset on Surface Link
MDT Lane-Widening
MDT Shoulder
MDT Daylight With Subbase

Parameter References for Right Side (Left is the same except for "Left" prefixes):

- MDT Parameter References

Input values:

Value Name	Default Input Value	Parameter Reference	
		Use	Get Value From
Side	Right	<input type="checkbox"/>	<None>
Pave1 depth	0.300'	<input type="checkbox"/>	<None>
Pave2 depth	0.000'	<input type="checkbox"/>	<None>
Base depth	0.500'	<input type="checkbox"/>	<None>
Subbase depth	2.000'	<input type="checkbox"/>	<None>
Lane 1 width	12.000'	<input type="checkbox"/>	<None>
Lane 2 width	10.000'	<input type="checkbox"/>	<None>
Lane 3 width	0.000'	<input type="checkbox"/>	<None>
Lane 4 width	0.000'	<input type="checkbox"/>	<None>
Lane 1 slope	-2.00%	<input type="checkbox"/>	<None>
Lane 2 slope	0.00%	<input type="checkbox"/>	<None>
Lane 3 slope	0.00%	<input type="checkbox"/>	<None>
Lane 4 slope	0.00%	<input type="checkbox"/>	<None>
Integer 1	0	<input type="checkbox"/>	<None>
Integer 2	0	<input type="checkbox"/>	<None>
Integer 3	0	<input type="checkbox"/>	<None>
Integer 4	0	<input type="checkbox"/>	<None>

- MDT Offset on Surface Link

Input values:

Value Name	Default Input Value	Parameter Reference	
		Use	Get Value From
Side	Right	<input type="checkbox"/>	<None>
Point Code Location Suffix	None	<input type="checkbox"/>	<None>
Offset to Surface	12.000	<input type="checkbox"/>	<None>
Offset to Acquire Slope	12.000	<input type="checkbox"/>	<None>
Omit Link	Yes	<input type="checkbox"/>	<None>
Custom Point Code Suffix	_L-In	<input type="checkbox"/>	<None>

- MDT Lane-Widening

Input values:

Value Name	Default Input Value	Parameter Reference	
		Use	Get Value From
Side	Right	<input type="checkbox"/>	<None>
Point Code Location Suffix	Automatic	<input type="checkbox"/>	<None>
Centerline	Attachment Point	<input type="checkbox"/>	<None>
Lane Width	12.000	<input type="checkbox"/>	<None>
Lane Slope	-2.00%	<input type="checkbox"/>	<None>
Slope Direction	Away from Crown	<input type="checkbox"/>	<None>
Pave1 Depth	0.300	<input checked="" type="checkbox"/>	Right-MDTParameterReferences.Pave1 depth value
Pave2 Depth	0.000	<input checked="" type="checkbox"/>	Right-MDTParameterReferences.Pave2 depth value
Base Depth	0.500	<input checked="" type="checkbox"/>	Right-MDTParameterReferences.Base depth value
Subbase Depth	2.000	<input checked="" type="checkbox"/>	Right-MDTParameterReferences.Subbase depth value
Use Superelevation	Right Outside Lane Slope	<input type="checkbox"/>	<None>
Base Extension Inside Width	0.000	<input type="checkbox"/>	<None>
Base Extension Outside Width	0.000	<input type="checkbox"/>	<None>
Add Construction Slope	No	<input type="checkbox"/>	<None>
Construction Slope	2.00:1	<input type="checkbox"/>	<None>
Custom Point Code Suffix	_L-In	<input type="checkbox"/>	<None>

- MDT Shoulder

Input values:

Value Name	Default Input Value	Parameter Reference	
		Use	Get Value From
Side	Right	<input type="checkbox"/>	<None>
Point Code Location Suffix	Automatic	<input type="checkbox"/>	<None>
Pave1 Depth	0.300	<input checked="" type="checkbox"/>	Right-MDTParameterReferences.Pave1 depth value
Pave2 Depth	0.000	<input checked="" type="checkbox"/>	Right-MDTParameterReferences.Pave2 depth value
Base Depth	0.500	<input checked="" type="checkbox"/>	Right-MDTParameterReferences.Base depth value
Pave Slope (Referenced from Lane)	-2.00%	<input checked="" type="checkbox"/>	Right-MDTLane-Widening.Lane Slope value %
Normal Crown Slope	-2.00%	<input type="checkbox"/>	<None>
Surfacing Inslope	6.00:1	<input type="checkbox"/>	<None>
Use Superelevation	None	<input type="checkbox"/>	<None>
Inslope Extension Offset	0.000	<input type="checkbox"/>	<None>
Geotextile Outside Edge Offset	3.000	<input type="checkbox"/>	<None>
Custom Point Code Suffix	_L-In	<input type="checkbox"/>	<None>

- MDT Daylight With Subbase

Input values:

Value Name	Default Input Value	Parameter Reference	
		Use	Get Value From
Side	Right	<input type="checkbox"/>	<None>
Select Subassembly build options	Daylight with Subbase	<input type="checkbox"/>	<None>
Point Code Location Suffix	Automatic	<input type="checkbox"/>	<None>
End Condition Options	Automatic	<input type="checkbox"/>	<None>
Foreslope	6.00:1	<input type="checkbox"/>	<None>
Foreslope Width	10.000	<input type="checkbox"/>	<None>
Ditch Width	10.000	<input type="checkbox"/>	<None>
Ditch Slope	-20.00:1	<input type="checkbox"/>	<None>
Minimum Ditch Depth	0.500	<input type="checkbox"/>	<None>
Cut Slope	-20.00:1	<input type="checkbox"/>	<None>
Pave1 Depth (Referenced from Lane)	0.300	<input checked="" type="checkbox"/>	Right-MDTParameterReferences.Pave1 depth value
Pave2 Depth (Referenced from Lane)	0.000	<input checked="" type="checkbox"/>	Right-MDTParameterReferences.Pave2 depth value
Base Depth (Referenced from Lane)	0.500	<input checked="" type="checkbox"/>	Right-MDTParameterReferences.Base depth value
Subbase Depth (Referenced from L...	2.000	<input checked="" type="checkbox"/>	Right-MDTParameterReferences.Subbase depth value
Normal Crown Base Distance (Refer...	5.500	<input checked="" type="checkbox"/>	Right-MDTShoulder.Normal Crown Base Distance value
Normal Crown Slope (Referenced fr...	-2.00%	<input checked="" type="checkbox"/>	Right-MDTShoulder.Normal Crown Slope value
SE Base Distance (Referenced from...	5.500	<input checked="" type="checkbox"/>	Right-MDTShoulder.SE Base Distance value
SE Base Slope (Referenced from S...	-2.00%	<input checked="" type="checkbox"/>	Right-MDTShoulder.SE Base Slope value
Inslope Extension Offset (Reference...	0.000	<input checked="" type="checkbox"/>	Right-MDTShoulder.Inslope Extension value
Rounded Surface Inslope (Referenc...	-0.165	<input checked="" type="checkbox"/>	Right-MDTShoulder.Rounded Surfacing Inslope value
Create Bathtub	Yes	<input type="checkbox"/>	<None>
Bathtub Slope	2.00:1	<input type="checkbox"/>	<None>
Custom Point Code Suffix	I-In	<input type="checkbox"/>	<None>

MDT DITCH BLOCK

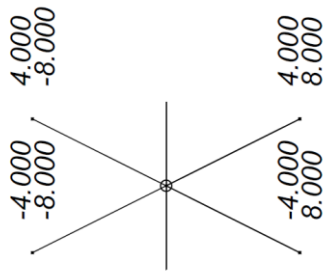

HOW THIS ASSEMBLY CAN BE USED:

The primary use for this assembly is modeling ditch blocks. This assembly uses cut and fill slope parameters to define daylight points on a surface. Daylight foreslope links between the insertion point and the daylight points are created.

Subassemblies Included:

Left	Right
MDT Slope to Surface Link	MDT Slope to Surface Link

Right Side (Left is the same except for “Left” prefixes):

- MDT Slope to Surface Link

Input values:				
Value Name	Default Input Value	Parameter Reference		
		Use	Get Value From	
Side	Right	<input type="checkbox"/>		<None>
Point Code Location Suffix	Automatic	<input type="checkbox"/>		<None>
Cut/Fill Option	Both	<input type="checkbox"/>		<None>
Cut Slope	5.00:1	<input type="checkbox"/>		<None>
Fill Slope	5.00:1	<input type="checkbox"/>		<None>
Number of Cut Intercepts (1 to 4)	1	<input type="checkbox"/>		<None>
Number of Fill Intercepts (1 to 4)	1	<input type="checkbox"/>		<None>
Material Thickness	0.000	<input type="checkbox"/>		<None>
Custom Point Code Suffix	_L-In	<input type="checkbox"/>		<None>
[P1] Attachment point		<input type="checkbox"/>		<None>
[P2] Daylight Fill point	Daylight,Daylight_Fill	<input type="checkbox"/>		<None>
[P3] Daylight Cut point	Daylight,Daylight_Cut	<input type="checkbox"/>		<None>
[P4] Material Bottom Inside	Material_Bottom_In	<input type="checkbox"/>		<None>
[P5] Material Bottom Outside	Material_Bottom_Out	<input type="checkbox"/>		<None>
[L1] Daylight Fill	LabelSlope,Top,Datum,Daylight_Fill	<input type="checkbox"/>		<None>
[L2] Daylight Cut	LabelSlope,Top,Datum,Daylight_Cut	<input type="checkbox"/>		<None>
[S1] Material		<input type="checkbox"/>		<None>

LINKS

This assembly has two links that connect the baseline to daylight points right and left on a target surface.

INPUT PARAMETERS

Display name	Description	Type	Default
Side	Specifies which side to place the subassembly	None/Left/Right	Left & Right
Point Code Location Suffix	Adds a suffix to point codes.	None/Right Left/Automatic/ CustomCode	None
Cut/Fill Option	Specifies cut or fill option	Cut/Fill	Fill
Cut Slope	Sets the cut slope value	Slope	10.00:1
Fill Slope	Sets the fill slope value	Slope	10.00:1
Number of Cut Intercepts (1 to 4)	Number of cut intercepts (1 to 4)	Integer	1
Number of Fill Intercepts (1 to 4)	Number of fill intercepts (1 to 4)	Integer	1
Material Thickness	Assign a material thickness to the link	Double, positive	0
Custom Point Code Suffix	Custom Suffix characters	String	_L-In
[P1] Attachment point	Attachment point	String	Attachment point
[P2] Daylight Fill Point	Daylight point if fill	String	Daylight_Fill, Daylight

Display name	Description	Type	Default
[P3] Daylight Cut Point	Daylight point if cut	String	Daylight_Cut, Daylight
[P4] Material Bottom Inside	Inside point on the bottom of the material layer	String	Material_Bottom_In
[P5] Material Bottom Outside	Outside point on the bottom of the material layer	String	Material_Bottom_Out
[L1] Daylight Fill	Daylight fill surface	String	Daylight_Fill, Top, Datum
[L2] Daylight Cut	Daylight cut surface	String	Daylight_Cut, Top, Datum
[S1] Material	Material layer	String	

TARGET PARAMETERS

Display Name	Description	Type
Daylight Surface	Surface	Surface
Cut Slope Control Profile	Control Profile	Elevation
Fill Slope Control Profile	Control Profile	Elevation
Cut or Fill Switch (Both 0, +Fill, -Cut)	Switch	Elevation

OUTPUT PARAMETERS

Display Name	Description	Type	Default
Final Slope Value	Final slope value	Slope	2.00:1
Daylight Offset Value	Daylight offset value	Double	0
Daylight Elevation value	Daylight elevation value	Double	0

BEHAVIOR

This assembly requires surface targets and an input **Cut Slope** and **Fill Slope** parameter value or defined Control Profile target slope for each subassembly. The assembly creates a point on the attachment point and points on the surface based on the slope parameters provided and the cut or fill condition at the insertion point location. Links connect the attachment point to the points on the surface.

The subassemblies have an option to determine how many times the target surface will be intercepted before a final daylight point is created. There is a separate Intercept parameter for cut and for fill. The number of surface intercepts in a cut condition is defined with the **Number of Cut Intercepts (1 to 4)** parameter, and the number of surface intercepts in a fill condition is defined with the **Number of Fill Intercepts (1 to 4)** parameter. If the subassembly is set to solve only a fill condition and doesn't intersect the surface target the subassembly will default back to a cut condition.

LAYOUT MODE OPERATION

Layout mode shows the graphic cut/fill slopes of the assembly.

CODING DIAGRAMS

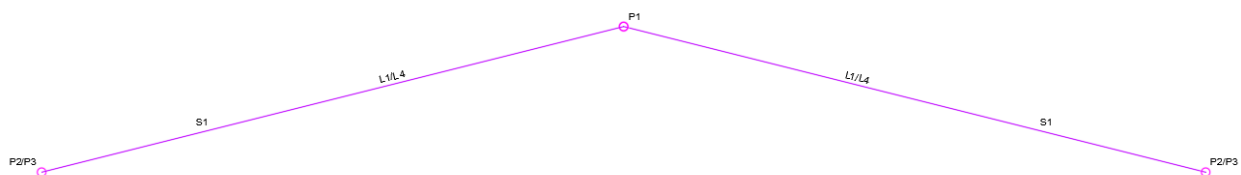

MDT TYPICAL ROADWAY ASSEMBLY CONSTRUCTION

This section demonstrates an example of how to construct a typical roadway Assembly representing a two-lane roadway, with 4-foot wide shoulders at the same roadway slope, a lane shoulder transitional section with differing grades in superelevation condition, and a fill slope or cut ditch. The Assembly utilizes MDT Lane, MDT Shoulder, MDT Daylight with Subbase, and MDT Parameter References Subassemblies.

ASSEMBLY BUILD INSTRUCTIONS

CREATE ASSEMBLY

1. Home tab > Create Design panel > Assembly drop-down > Create Assembly

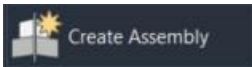

2. Enter the Assembly Name, Description, Assembly Type, Assembly style, and set the Code set style.
3. Click "OK"

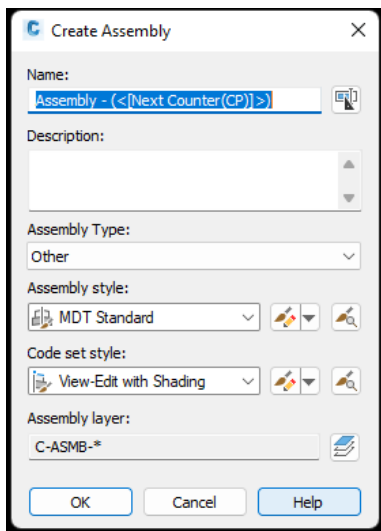

Note: All of the items in the Create Assembly dialog box can also be changed after the Assembly has been created.

4. Select a location in your drawing for the Assembly and left-click to place the Assembly marker.
5. The MDTPParameterReferences Subassembly will be used to automatically control some Subassembly parameter settings throughout the Assembly. The MDTPParameterReferences Subassembly settings can be configured either pre- or post-placement.

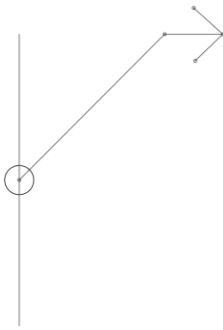

PRE-PLACEMENT

- Select the MDTPParameterReferences Subassembly on the MDT Subassemblies Tool palette.
- The Properties palette will appear.
- Set the parameters before placing the subassembly.

General	
Data	
ADVANCED	
Parameters	
Integer 1 value	0
Integer 2 value	0
Integer 3 value	0
Integer 4 value	0
Side	Right
Base depth value	0.000
Lane 1 slope value	0.000
Lane 1 width value	0.000
Lane 2 slope value	0.000
Lane 2 width value	0.000
Lane 3 slope value	0.000
Lane 3 width value	0.000
Lane 4 slope value	0.000
Lane 4 width value	0.000
Pave1 depth value	0.000
Pave2 depth value	0.000
Subbase depth value	0.000
Pave1 depth	0.300'
Pave2 depth	0.000'
Base depth	0.500'
Subbase depth	2.000'
Lane 1 width	12.000'
Lane 2 width	4.000'
Lane 3 width	0.000'
Lane 4 width	0.000'
Lane 1 slope	-2.00%
Lane 2 slope	-2.00%
Lane 3 slope	-2.00%
Lane 4 slope	0.00%
Integer 1	0
Integer 2	0
Integer 3	0
Integer 4	0

- Place the Subassembly into the Assembly by selecting the marker attachment point on the Assembly marker. Press **Esc** on the keyboard to exit the command.

POST PLACEMENT

- Select the MDTPParameterReferences Subassembly on the MDT Subassemblies Tool palette and place the Subassembly onto the Assembly by selecting the marker attachment point on the Assembly marker. Press **Esc** on the keyboard to exit the command.

- b. Select the MDTPParameterReferences Subassembly, right-click and select **Subassembly Properties...** from the right-click menu.
- c. From the **Parameters** tab, set the parameters.

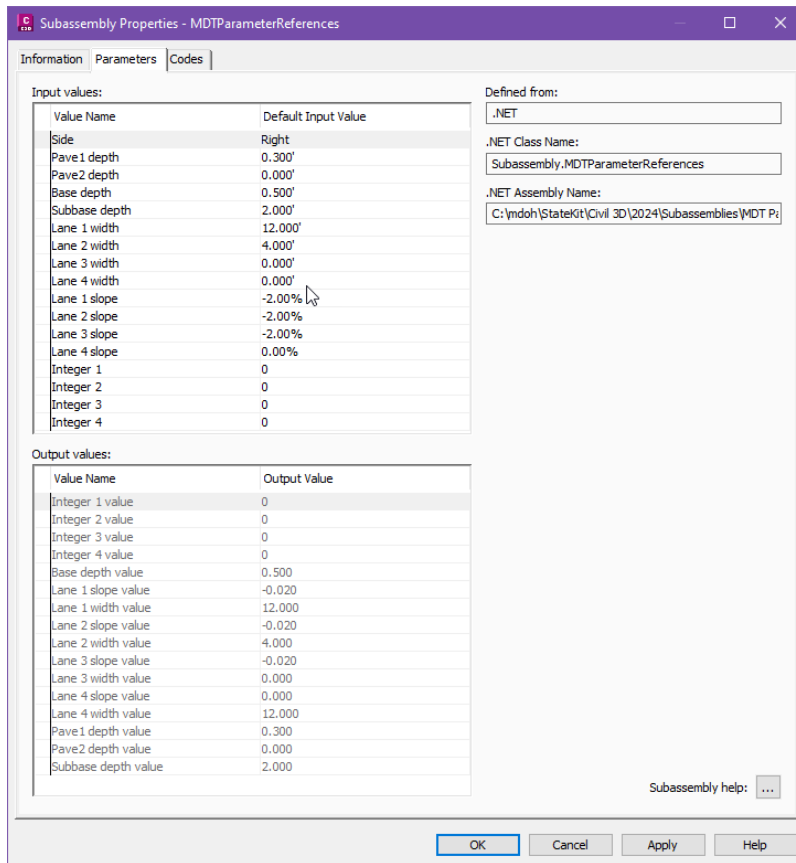

6. Set the parameters as shown in the following image.

Value Name	Default Input Value
Side	Right
Pave1 depth	0.300'
Pave2 depth	0.000'
Base depth	0.500'
Subbase depth	2.000'
Lane 1 width	12.000'
Lane 2 width	4.000'
Lane 3 width	0.000'
Lane 4 width	0.000'
Lane 1 slope	-2.00%
Lane 2 slope	-2.00%
Lane 3 slope	-2.00%
Lane 4 slope	0.00%
Integer 1	0
Integer 2	0
Integer 3	0
Integer 4	0

7. From the MDT Subassemblies Tool palette, select the **MDT Lane** Subassembly.

8. Select the **MDT Parameter References** Subassembly attachment point to place the Subassembly.

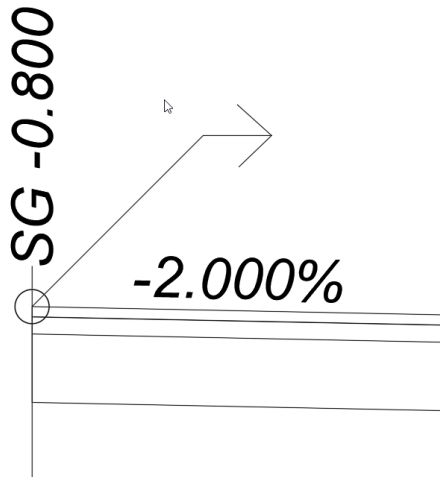

9. Repeat, to add another **MDT Lane** Subassembly. Attach it to the top right attachment point of the first **MDT Lane** Subassembly. Press **Esc** on the keyboard to exit the command.

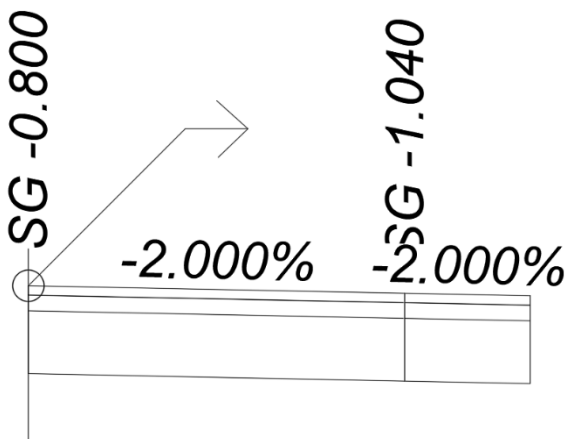

10. Select the **MDT Shoulder** Subassembly on the MDT Subassemblies Tool palette.
11. Place the Subassembly by selecting the top right attachment point of the second **MDT Lane** Subassembly. Press **Esc** on the keyboard to exit the command.

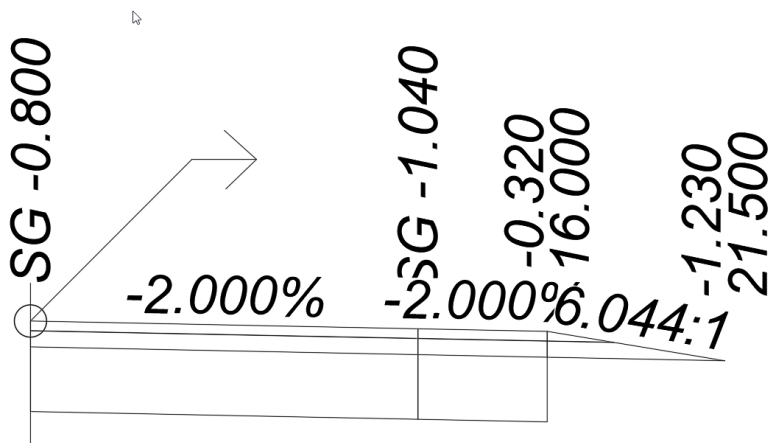

12. Select the **MDT Daylight with Subbase** Subassembly on the MDT Subassemblies Tool palette.
13. Place the Subassembly, by selecting the hinge attachment point of the **MDT Shoulder** Subassembly. Press **Esc** on the keyboard to exit the command.

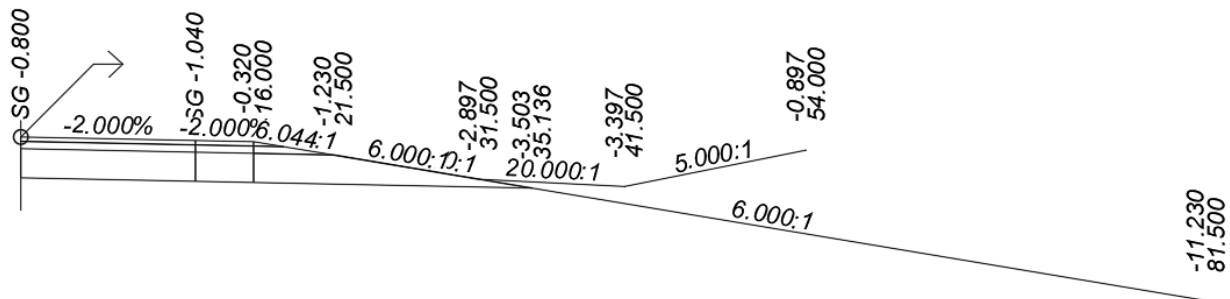

14. The right side is complete.
15. There are two options to add the Subassemblies to the left side.
 - a. Option One:
 - i. Repeat the steps for the left side but modify the “Side” parameter from “Right” to “Left” in the Properties palette during placement.
 - b. Option Two:
 - i. **First** select **all** the Subassemblies on the right side.
 - ii. Locate the Civil 3D **Mirror** Subassembly command:
Ribbon > Subassembly tab > Modify Subassembly panel > Mirror
 - c. When prompted, select the center Assembly marker attachment point.

*Note: **Never** use the standard AutoCAD commands COPY, MOVE, or MIRROR to copy, move, or mirror Subassemblies. This will result in errors in the corridor and corridor surface(s). **Always** use the Civil 3D Copy, Move, and Mirror commands on the Subassemblies ribbon tab to copy, move, or mirror subassemblies.*
16. The Assembly should resemble the one shown below.

Subassemblies as shown in the image below.

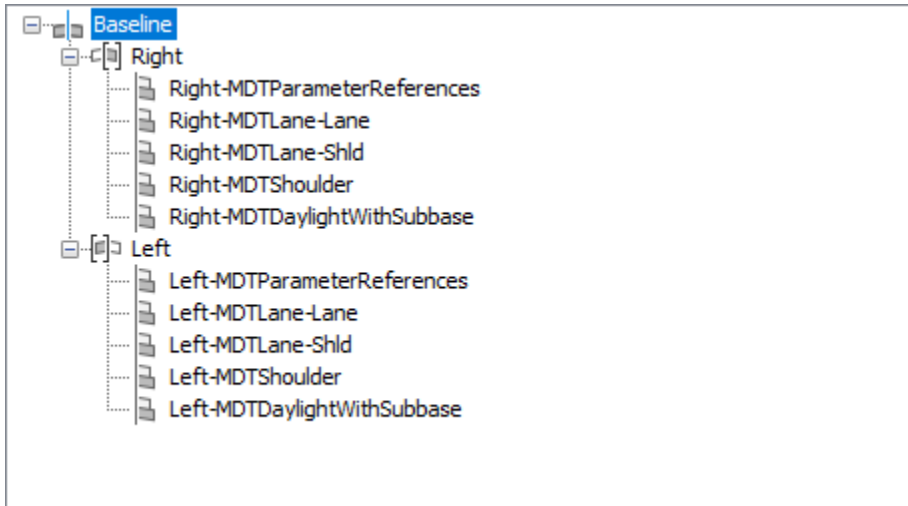

22. For each Subassembly in the Assembly trees, select the Subassembly name to set parameters, and assign parameter references. Set the parameters and parameter references as shown in the following images.

Right-MDTLane – Lane

Value Name	Default Input Value	Parameter Reference	
		Use	Get Value From
Side	Right	<input type="checkbox"/>	<None>
Centerline	Attachment Point	<input type="checkbox"/>	<None>
Lane Width	12.000'	<input checked="" type="checkbox"/>	Right-MDTPParameterReferences.Lane 1 width value
Lane Slope	-2.00%	<input type="checkbox"/>	<None>
Slope Direction	Away from Crown	<input type="checkbox"/>	<None>
Pave1 Depth	0.300'	<input checked="" type="checkbox"/>	Right-MDTPParameterReferences.Pave1 depth value
Pave2 Depth	0.000'	<input checked="" type="checkbox"/>	Right-MDTPParameterReferences.Pave2 depth value
Base Depth	0.500'	<input checked="" type="checkbox"/>	Right-MDTPParameterReferences.Base depth value
Subbase Depth	2.000'	<input checked="" type="checkbox"/>	Right-MDTPParameterReferences.Subbase depth value
Use Superelevation	Right Outside Lane Slope	<input type="checkbox"/>	<None>
Base Extension Inside Width	0.000'	<input type="checkbox"/>	<None>
Base Extension Outside Width	0.000'	<input type="checkbox"/>	<None>
Add Construction Slope	No	<input type="checkbox"/>	<None>

Right-MDTLane– Shld

Value Name	Default Input Value	Parameter Reference	
		Use	Get Value From
Side	Right	<input type="checkbox"/>	<None>
Centerline	Attachment Point	<input type="checkbox"/>	<None>
Lane Width	4.000'	<input checked="" type="checkbox"/>	Right-MDTPParameterReferences.Lane 2 width value
Lane Slope	-2.00%	<input checked="" type="checkbox"/>	Right-MDTLane-Lane.Lane Slope value %
Slope Direction	Away from Crown	<input type="checkbox"/>	<None>
Pave1 Depth	0.300'	<input checked="" type="checkbox"/>	Right-MDTPParameterReferences.Pave1 depth value
Pave2 Depth	0.000'	<input checked="" type="checkbox"/>	Right-MDTPParameterReferences.Pave2 depth value
Base Depth	0.500'	<input checked="" type="checkbox"/>	Right-MDTPParameterReferences.Base depth value
Subbase Depth	2.000'	<input checked="" type="checkbox"/>	Right-MDTPParameterReferences.Subbase depth value
Use Superelevation	None	<input type="checkbox"/>	<None>
Base Extension Inside Width	0.000'	<input type="checkbox"/>	<None>
Base Extension Outside Width	0.000'	<input type="checkbox"/>	<None>
Add Construction Slope	No	<input type="checkbox"/>	<None>

Right-MDTShoulder

Value Name	Default Input Value	Parameter Reference	
		Use	Get Value From
Side	Right	<input type="checkbox"/>	<None>
Pave1 Depth	0.300'	<input checked="" type="checkbox"/>	Right-MDTParameterReferences.Pave 1 depth value
Pave2 Depth	0.000'	<input checked="" type="checkbox"/>	Right-MDTParameterReferences.Pave2 depth value
Pave Slope (Referenced from ...)	-2.00%	<input checked="" type="checkbox"/>	Right-MDTLane-Lane.Lane Slope value %
Base Depth	0.500'	<input checked="" type="checkbox"/>	Right-MDTParameterReferences.Base depth value
Normal Crown Slope	-2.00%	<input type="checkbox"/>	<None>
Surfacing Inslope	6.00:1	<input type="checkbox"/>	<None>
Use Superelevation	None	<input type="checkbox"/>	<None>
Inslope Extension Offset	0.000	<input type="checkbox"/>	<None>

Right-MDTDaylightWithSubbase

Value Name	Default Input Value	Parameter Reference	
		Use	Get Value From
Side	Right	<input type="checkbox"/>	<None>
Select Subassembly build options	Daylight with Subbase	<input type="checkbox"/>	<None>
Foreslope	6.00:1	<input type="checkbox"/>	<None>
Foreslope Width	10.000'	<input type="checkbox"/>	<None>
Ditch Width	10.000'	<input type="checkbox"/>	<None>
Ditch Slope	-20.00:1	<input type="checkbox"/>	<None>
Cut Slope	-20.00:1	<input type="checkbox"/>	<None>
Cut Width	50.000'	<input type="checkbox"/>	<None>
Pave1 Depth (Referenced from ...)	0.300'	<input checked="" type="checkbox"/>	Right-MDTParameterReferences.Pave 1 depth value
Pave2 Depth (Referenced from ...)	0.000'	<input checked="" type="checkbox"/>	Right-MDTParameterReferences.Pave2 depth value
Base Depth (Referenced from ...)	0.500'	<input checked="" type="checkbox"/>	Right-MDTParameterReferences.Base depth value
Subbase Depth (Referenced from ...)	2.000'	<input checked="" type="checkbox"/>	Right-MDTParameterReferences.Subbase depth value
Normal Crown Base Distance (...)	5.500'	<input checked="" type="checkbox"/>	Right-MDTShoulder.Normal Crown Base Distance value
Normal Crown Slope (Referenc...	-2.00%	<input checked="" type="checkbox"/>	Right-MDTShoulder.Normal Crown Slope value
SE Base Distance (Referenced...	5.500'	<input checked="" type="checkbox"/>	Right-MDTShoulder.SE Base Distance value
SE Base Slope (Referenced fro...	-2.00%	<input checked="" type="checkbox"/>	Right-MDTShoulder.SE Base Slope value
Inslope Extension Offset (Ref...	0.000'	<input checked="" type="checkbox"/>	Right-MDTShoulder.Inslope Extension value
Rounded Surface Inslope (Ref...	-0.165'	<input checked="" type="checkbox"/>	Right-MDTShoulder.Rounded Surfacing Inslope value
Create Bathtub	Yes	<input type="checkbox"/>	<None>
Bathtub Slope	2.00:1	<input type="checkbox"/>	<None>

23. Set the parameters for the left side Subassemblies the same as the right side, but use the "Left-" prefix Subassemblies for the parameter references.

The Assembly is now complete and ready for use with a corridor.